

---

# HA1835P/HA1848P

## Watchdog Timer

# HITACHI

---

### Description

The HA1835P and HA1848P is a monolithic voltage regulator control designed for microcomputer systems. In addition to the voltage regulator, it include watchdog timer function and power-on reset function.

These ICs can perform many function in various microcomputer systems with few external parts.

### Features

- Regulated power supply control function
  - Wide area of operational voltage;  $V_{CC} = 6\text{ V to }30\text{ V}$
  - Available external PNP-type transistor, suited to any system power supply
  - Built-in overcurrent limiter for external PNP-type transistor
  - Output voltage can be adjusted exactry in the range from 4 V to 6 V
- Watchdog timer
  - Internal bandpass filter control circuit (pulse width detect type) and reset signal oscillator
  - Fail-safe utility
  - Bandpass filter characteristics can be set by external resistor ( $R_f$ ) and capacitance ( $C_f$ )
- Automatic reset
  - Automatic power-on reset
  - Pulse generator characteristics can be set by external resistor ( $R_R$ ) and capacitance ( $C_R$ )
  - Alternative between  $\overline{\text{RES}}$  and RES output

## Pin Arrangement

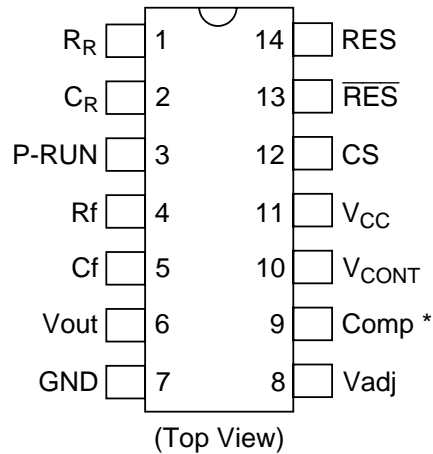

Note: HA1848P: 9 pin is non connection.

## Pin Functions

Pin No.	Symbol	Functions
1	$R_R$	Reset pulse width depends on resistance connected to $R_R$ Recommended range: 100 k $\Omega$ to 1 M $\Omega$
2	$C_R$	Reset pulse width depends on capacitance connected to $C_R$
3	P-RUN	Clock pulse input terminal for watchdog timer
4	$R_f$	Frequency band width of filter circuit depends on resistance connected to $R_f$ Recommended range: 100 k $\Omega$ to 500 k $\Omega$
5	$C_f$	Frequency band width of filter circuit depends on capacitance connected to $C_f$
6	Vout	Connect to external PNP transistor's collector: This pin supplies 5 V regulated voltage for internal circuit
7	GND	Ground
8	Vadj	Output voltage fine tuning terminal
9	Comp	Phase compensation terminal: Connect less than 100 pF capacitor between $V_{CC}$ and Comp. HA1848P is non connection
10	$V_{CONT}$	External PNP transistor's base control terminal
11	$V_{CC}$	Supply voltage terminal: Operating supply voltage range is 6 V to 30 V
12	CS	Connect current sense resistor, which protects the external PNP transistor, between $V_{CC}$ and CS
13	$\overline{RES}$ *	Reset pulse output terminal for low level reset type microcomputer
14	RES *	Reset pulse output terminal for high level reset type microcomputer

Note:  $\overline{RES}$  and RES are open-collector output terminals, so connect a pull-up resistor of about 5 k $\Omega$ .

Block Diagram

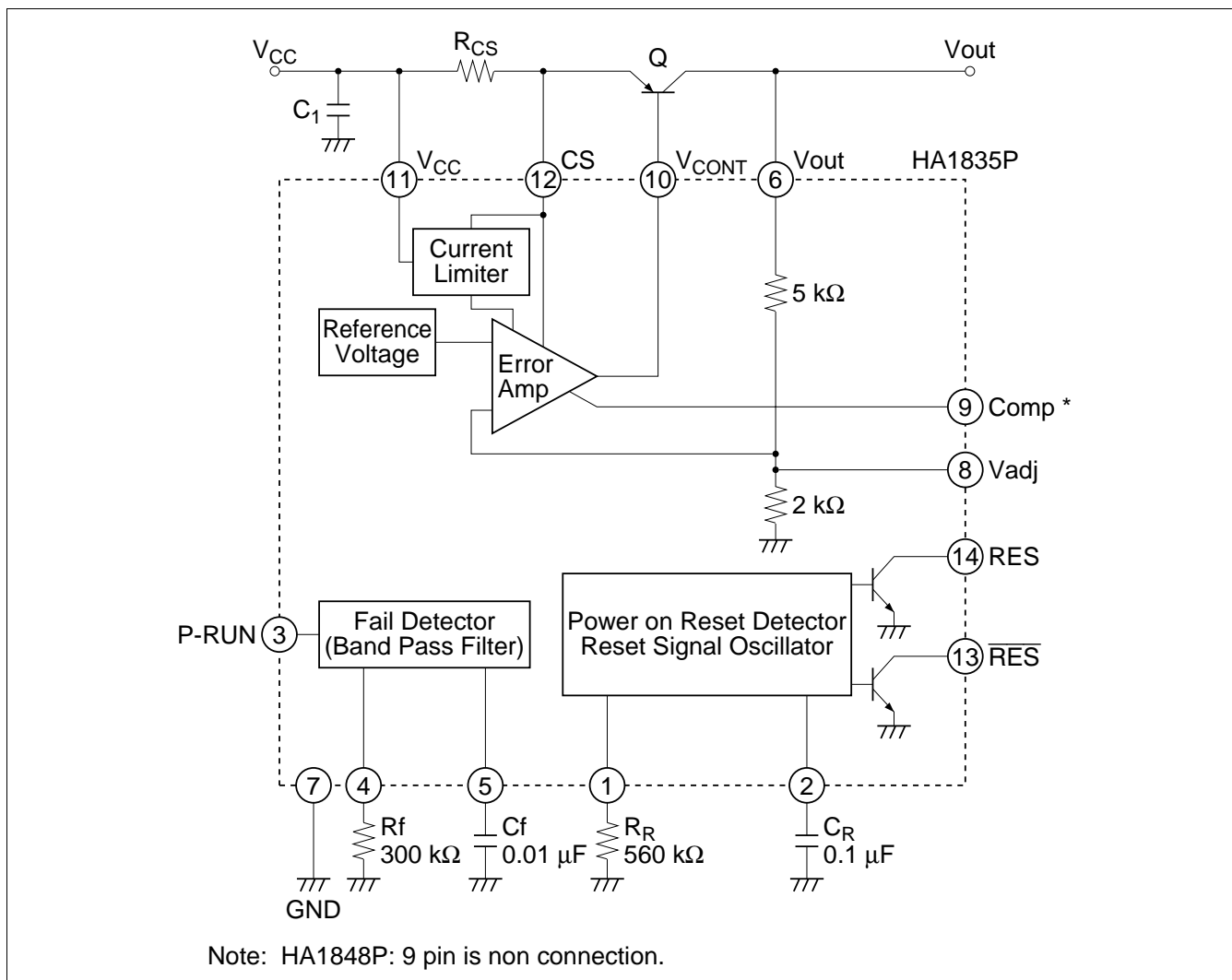

**Absolute Maximum Ratings (Ta = 25°C)**

Item	Symbol	Rating	Unit
Supply voltage	$V_{CC}$	30	V
P-RUN input voltage	$V_{P-RUN}$	-0.3 to Vout	V
Output voltage	$V_{RES}$	17.5	V
	$V_{RES}$	17.5	V
Output current	$I_{RES}$	2	mA
	$I_{RES}$	2	mA
Control terminal voltage	$V_{CONT}$	$V_{CC}$	V
Control terminal current	$I_{CONT}$	20	mA
Power dissipation (Note)	$P_T^*$	400	mW
Operating temperature range	Topr	-40 to +85	°C
Storage temperature range	Tstg	-50 to +125	°C
Soldering temperature	Tsol	+260 (< 10 sec)	°C

Note: Ta ≤ 77°C. If Ta > 77°C, derate by 8.3 mW/°C.

**Electrical Characteristics** ( $V_{CC} = 12\text{ V}$ ,  $V_{out} = 5\text{ V}$ ,  $T_a = 25^\circ\text{C}$ )

Item		Symbol	Min	Typ	Max	Unit	Test Conditions
Power supply terminal current		$I_{CC}$	—	6.3	12	mA	$V_{CC} = 17.5\text{ V}$ (No load), with PNP transistor
Regulator section	Output voltage	$V_{out1}$	4.75	5.00	5.25	V	$V_{CC} = 6\text{ to }17.5\text{ V}$ , $I_{out} = 0.5\text{ A}$
		$V_{out2}$	4.70	5.00	5.30	V	$V_{CC} = 6\text{ to }17.5\text{ V}$ , $I_{out} = 1\text{ A}$
	Line regulation	$\delta V_{Oline}$	-50	—	+50	mV	$V_{CC} = 6\text{ to }17.5\text{ V}$ , $I_{out} = 1\text{ A}$
	Load regulation	$\delta V_{Oload}$	-100	—	+100	mV	$I_{out} = 10\text{ mA to }0.5\text{ A}$
	Ripple rejection	$R_{REJ}$	40	75	—	dB	$e_i = 0.5\text{ V}_{rms}$ , $f_i = 1\text{ kHz}$
	Limiter operating current	$I_{CS}$	1.0	—	2.0	A	$R_{SC} = 0.2\ \Omega$
	Output voltage temperature coefficient	$\delta V_{out}/\delta T$	—	-0.6	—	mV/°C	
P-RUN input section	Low-level input voltage	$V_{IL}$	—	—	0.8	V	
	High-level input voltage	$V_{IH}$	2.0	—	—	V	
	Low-level input current	$I_{iL}$	-120	-60	—	$\mu\text{A}$	$V_{iL} = 0\text{ V}$
	High-level input current	$I_{iH}$	—	1.8	3.0	mA	$V_{out} = 5\text{ V}$ , $V_{iH} = 5\text{ V}$
Reset circuit section	Reset terminal low-level voltage	$V_{OL1}$	—	—	0.4	V	$I_{OL} = 2\text{ mA}$
	Reset terminal leakage current	$I_{OH1}$	—	—	5.0	$\mu\text{A}$	$V_{OH} = 5\text{ V}$
		$I_{OH3}$	—	—	30	$\mu\text{A}$	$V_{OH} = 17.5\text{ V}$
Reset time	Power on time	$t_{on}$	80	130	200	ms	$R_f = 300\text{ k}\Omega$ , $R_R = 560\text{ k}\Omega$ ,
	Clock off reset time	$t_{off}$	60	130	220	ms	$C_f = 0.01\ \mu\text{F}$ , $C_R = 0.1\ \mu\text{F}$
	Reset pulse low-level time	$t_{RL}$	40	80	160	ms	
	Reset pulse high-level time	$t_{RH}$	50	100	200	ms	

## Test Circuit

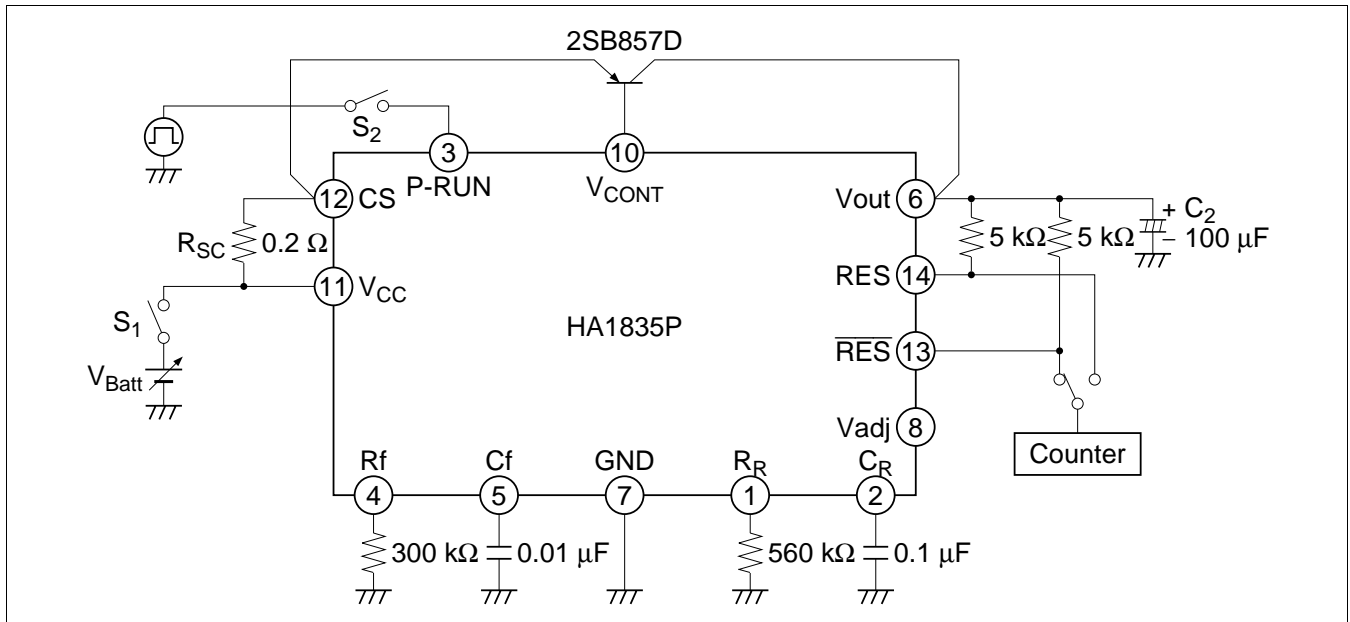

## Functional Description

### Voltage Regulator

The HA1835P, and HA1848P supplies 5 V regulated output from a wide  $V_{CC}$  input range ( $V_{CC} = 6$  V to 17.5 V). The external PNP transistor should be selected according to the supply current demand of the system. Connect a more than 100  $\mu$ F capacitor between  $V_{out}$  and GND to realize the 5 V regulated output.

The resistor connected from the  $V_{adj}$  terminal to the  $V_{out}$  or GND terminal fine tunes the output voltage. A resistor between  $V_{adj}$  and the  $V_{out}$  decreases the output voltage, and a resistor between  $V_{adj}$  and GND increases the output voltage.

$$R (V_{out} - V_{adj}) \approx \frac{5 \cdot V_{out} - 7.14}{5 - V_{out}} \quad (\text{k}\Omega)$$

$$R (V_{adj} - \text{GND}) \approx \frac{7.14}{V_{out} - 5} \quad (\text{k}\Omega)$$

### Current Limiter

To protect the external transistor from overcurrent, connect a current-sense resistor between the CS terminal and the  $V_{CC}$  terminal. The value of this resistor should be:

$$R_{SC} \approx \frac{0.3 \text{ V}}{I_{out} (\text{Limit})} \quad (\text{at } T_a = 25^\circ\text{C})$$

### Power-On Reset

The HA1835P, and HA1848P can output a reset pulse to start the microcomputer at power on (figure 6). The external resistor  $R_R$  and capacitor  $C_R$  determine the power-on reset timing.

Note that  $\overline{\text{RES}}$  and RES are open-collector terminals. They should therefore be connected to a pull-up resistor of about 5 k $\Omega$ .

### Watchdog Timer

The watchdog timer is a fail-safe function. It can reset the microcomputer system if the system runs out of control. It does this by monitoring a pulse output by the system's software. It uses a bandpass filter to determine whether the pulse frequency is within the system's normal frequency band (figure 7, 8). External resistor and capacitor  $R_f$  and  $C_f$  determine the frequency range of the bandpass filter. If the pulse frequency is not within the frequency band, the HA1835P, and HA1848P outputs a reset pulse.

## Application Circuit Example

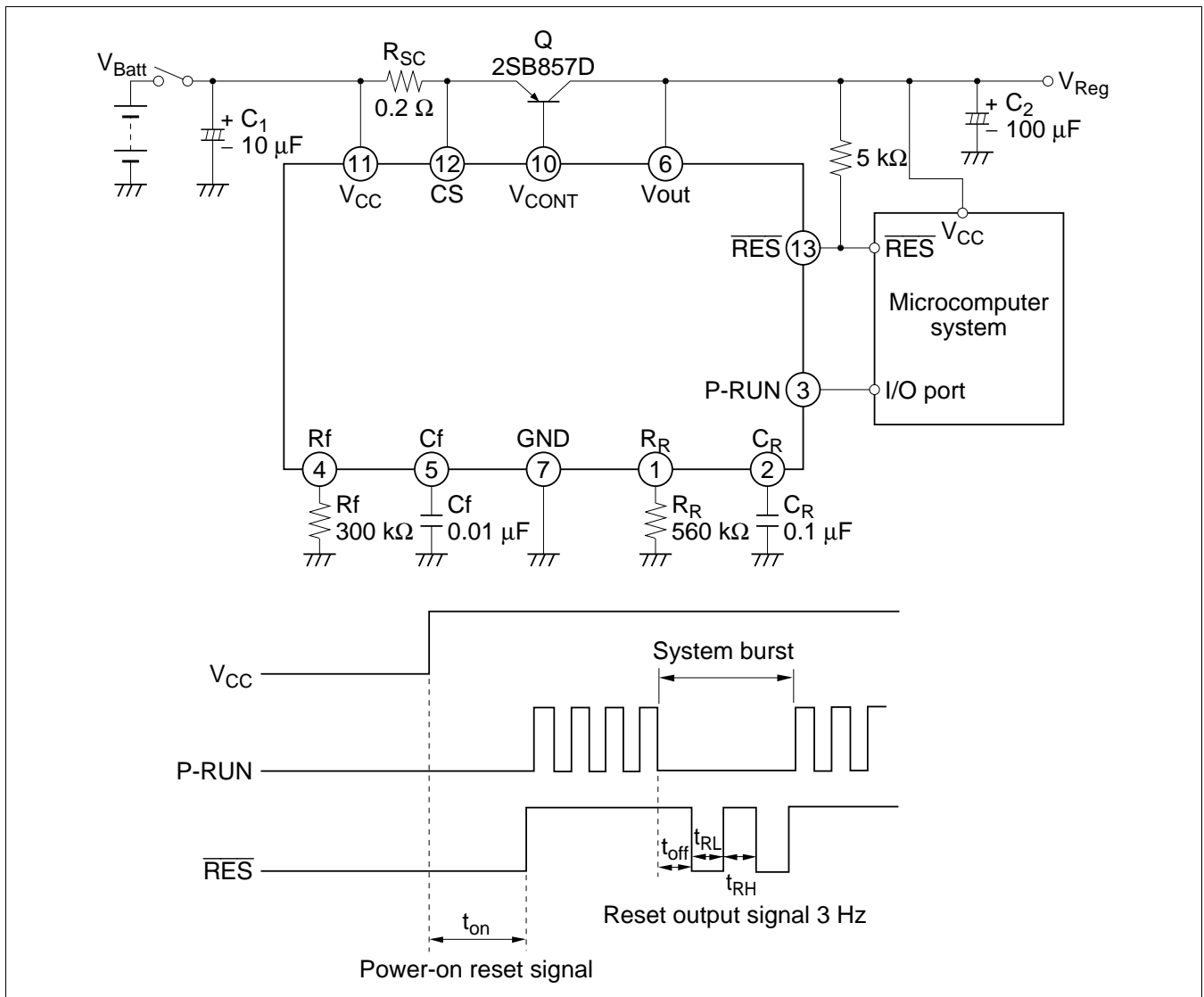



Characteristic Curves

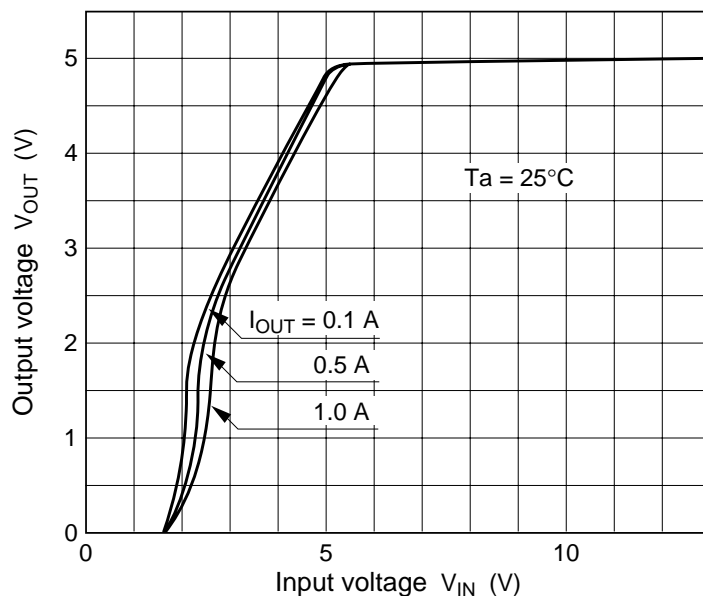

Figure 1 Output Voltage vs. Input Voltage

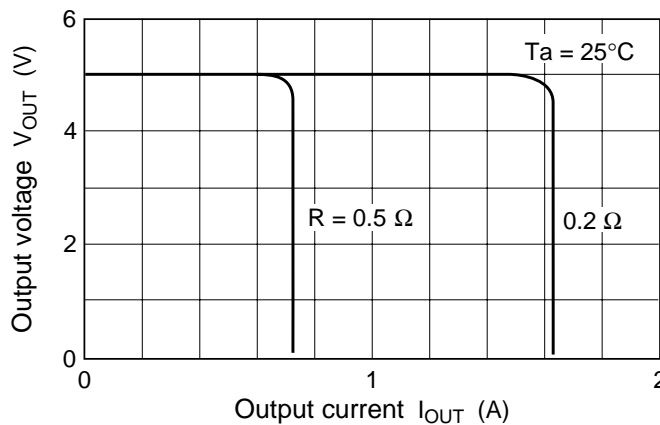

Figure 2 Output Voltage vs. Output Current

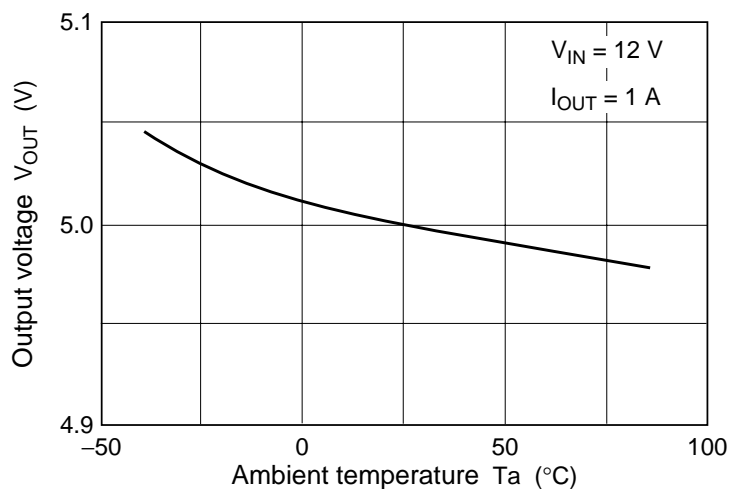

Figure 3 Output Voltage vs. Ambient Temperature

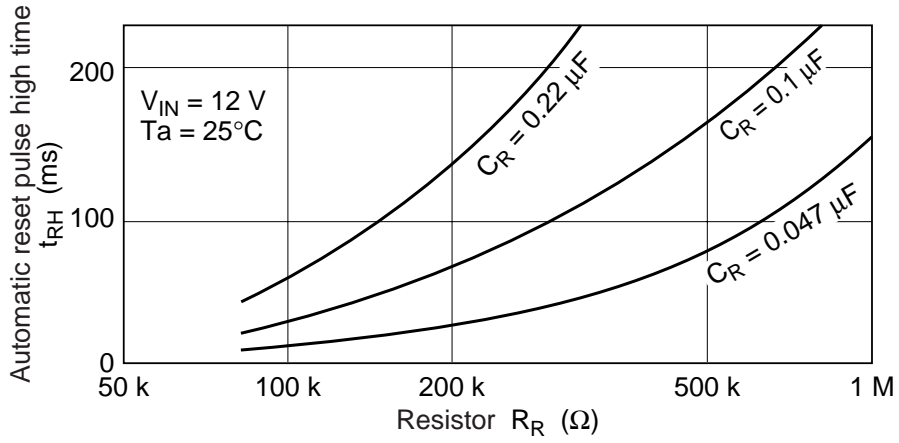

Figure 4 Automatic Reset Pulse High Time vs. Resistor

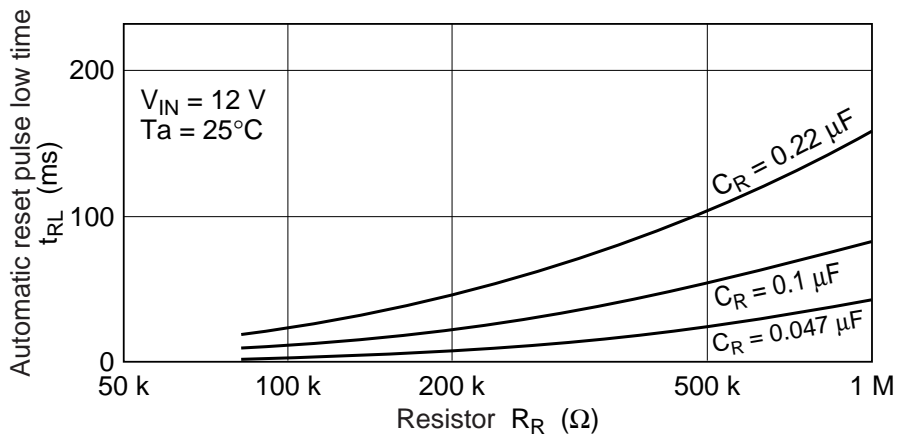

Figure 5 Automatic Reset Pulse Low Time vs. Resistor

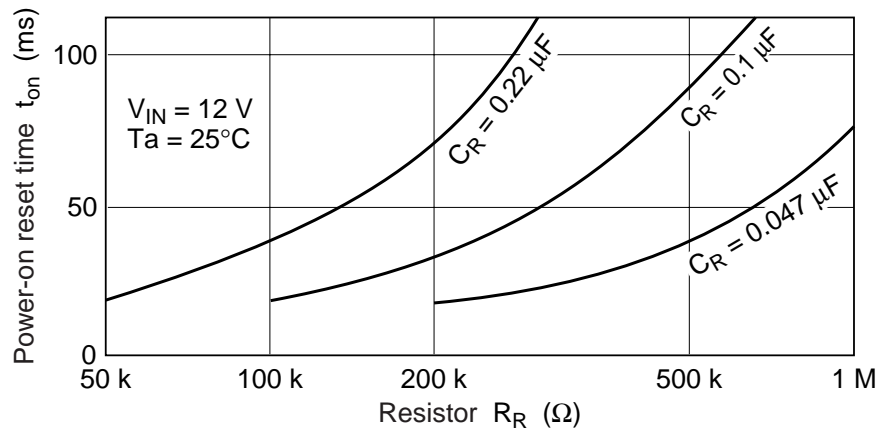

Figure 6 Power-on Reset Time vs. Resistor

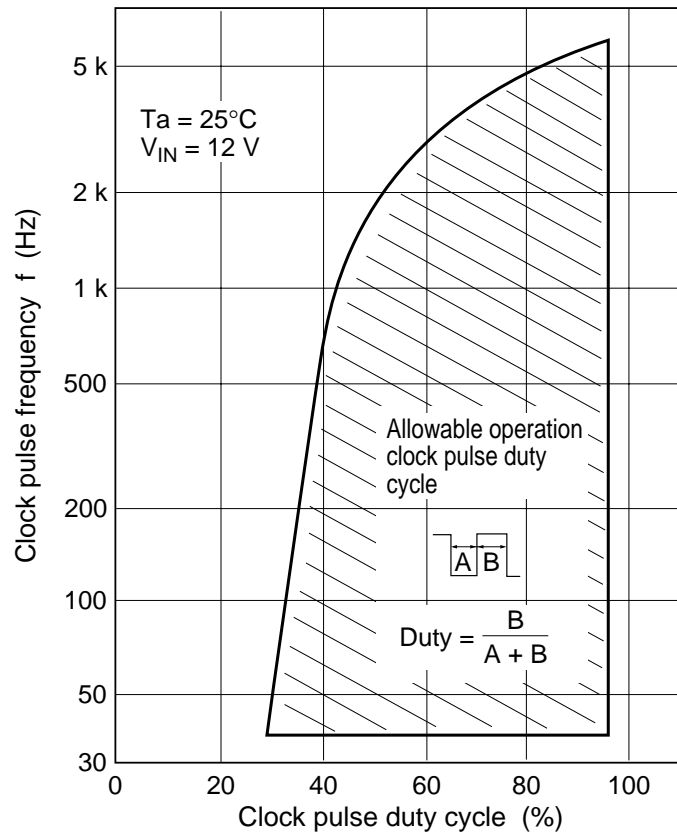

Figure 7 Clock Pulse Frequency vs. Clock Pulse Duty Cycle

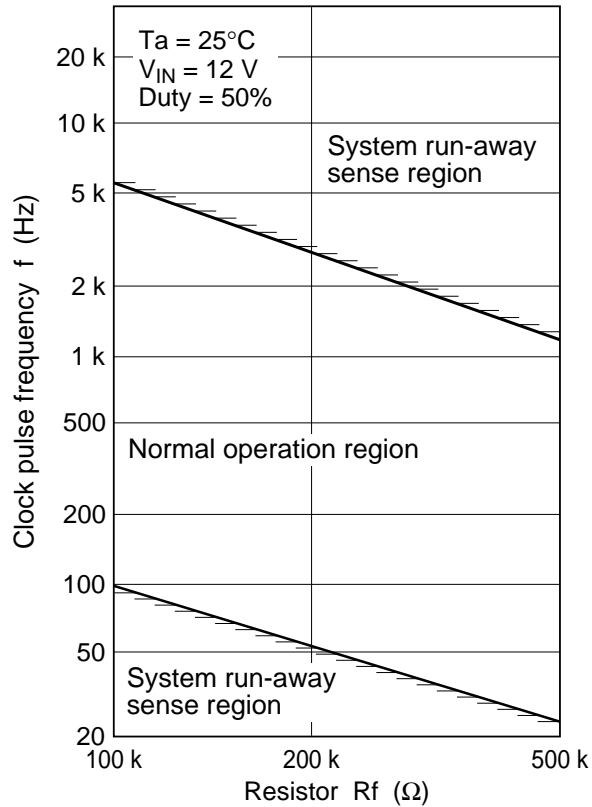
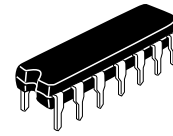
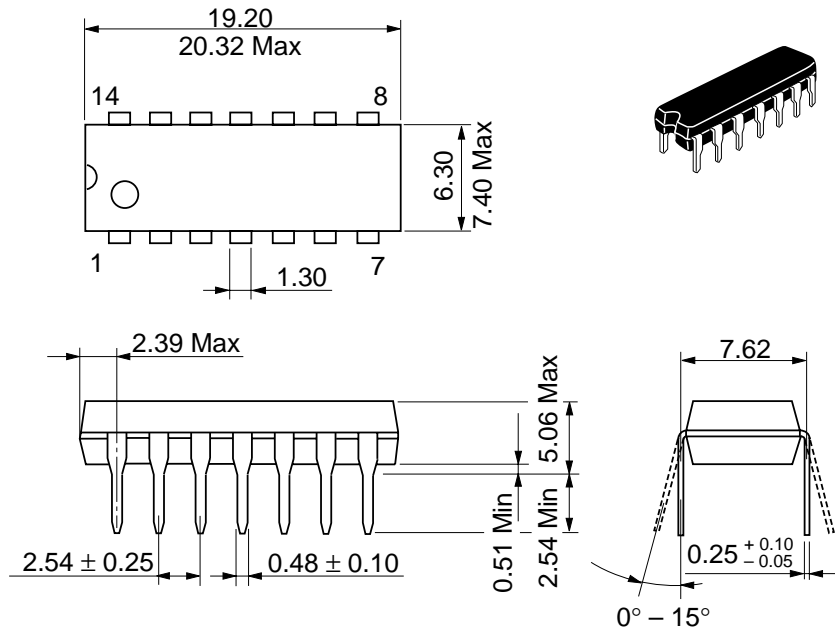

Figure 8 Clock Pulse Frequency vs. Resistor

## Package Dimensions

Unit: mm



Hitachi Code	DP-14
JEDEC	Conforms
EIAJ	Conforms
Mass (reference value)	0.97 g

## Cautions

1. Hitachi neither warrants nor grants licenses of any rights of Hitachi's or any third party's patent, copyright, trademark, or other intellectual property rights for information contained in this document. Hitachi bears no responsibility for problems that may arise with third party's rights, including intellectual property rights, in connection with use of the information contained in this document.
2. Products and product specifications may be subject to change without notice. Confirm that you have received the latest product standards or specifications before final design, purchase or use.
3. Hitachi makes every attempt to ensure that its products are of high quality and reliability. However, contact Hitachi's sales office before using the product in an application that demands especially high quality and reliability or where its failure or malfunction may directly threaten human life or cause risk of bodily injury, such as aerospace, aeronautics, nuclear power, combustion control, transportation, traffic, safety equipment or medical equipment for life support.
4. Design your application so that the product is used within the ranges guaranteed by Hitachi particularly for maximum rating, operating supply voltage range, heat radiation characteristics, installation conditions and other characteristics. Hitachi bears no responsibility for failure or damage when used beyond the guaranteed ranges. Even within the guaranteed ranges, consider normally foreseeable failure rates or failure modes in semiconductor devices and employ systemic measures such as fail-safes, so that the equipment incorporating Hitachi product does not cause bodily injury, fire or other consequential damage due to operation of the Hitachi product.
5. This product is not designed to be radiation resistant.
6. No one is permitted to reproduce or duplicate, in any form, the whole or part of this document without written approval from Hitachi.
7. Contact Hitachi's sales office for any questions regarding this document or Hitachi semiconductor products.

# HITACHI

## Hitachi, Ltd.

Semiconductor & Integrated Circuits.

Nippon Bldg., 2-6-2, Ohte-machi, Chiyoda-ku, Tokyo 100-0004, Japan

Tel: Tokyo (03) 3270-2111 Fax: (03) 3270-5109

URL           North America       : <http://semiconductor.hitachi.com/>  
                   Europe                 : <http://www.hitachi-eu.com/hel/ecg>  
                   Asia (Singapore)       : <http://www.has.hitachi.com.sg/grp3/sicd/index.htm>  
                   Asia (Taiwan)           : [http://www.hitachi.com.tw/E/Product/SICD\\_Frame.htm](http://www.hitachi.com.tw/E/Product/SICD_Frame.htm)  
                   Asia (HongKong)       : <http://www.hitachi.com.hk/eng/bo/grp3/index.htm>  
                   Japan                     : <http://www.hitachi.co.jp/Sicd/indx.htm>

### For further information write to:

Hitachi Semiconductor  
(America) Inc.  
179 East Tasman Drive,  
San Jose, CA 95134  
Tel: <1> (408) 433-1990  
Fax: <1>(408) 433-0223

Hitachi Europe GmbH  
Electronic components Group  
Dornacher Straße 3  
D-85622 Feldkirchen, Munich  
Germany  
Tel: <49> (89) 9 9180-0  
Fax: <49> (89) 9 29 30 00

Hitachi Europe Ltd.  
Electronic Components Group.  
Whitebrook Park  
Lower Cookham Road  
Maidenhead  
Berkshire SL6 8YA, United Kingdom  
Tel: <44> (1628) 585000  
Fax: <44> (1628) 778322

Hitachi Asia Pte. Ltd.  
16 Collyer Quay #20-00  
Hitachi Tower  
Singapore 049318  
Tel: 535-2100  
Fax: 535-1533

Hitachi Asia Ltd.  
Taipei Branch Office  
3F, Hung Kuo Building, No.167,  
Tun-Hwa North Road, Taipei (105)  
Tel: <886> (2) 2718-3666  
Fax: <886> (2) 2718-8180

Hitachi Asia (Hong Kong) Ltd.  
Group III (Electronic Components)  
7/F., North Tower, World Finance Centre,  
Harbour City, Canton Road, Tsim Sha Tsui,  
Kowloon, Hong Kong  
Tel: <852> (2) 735 9218  
Fax: <852> (2) 730 0281  
Telex: 40815 HITEC HX

Copyright ' Hitachi, Ltd., 1998. All rights reserved. Printed in Japan.

## HITACHI