

5300 PIXELS × 3 COLOR CCD LINEAR IMAGE SENSOR

The μ PD3799 is a color CCD (Charge Coupled Device) linear image sensor which changes optical images to electrical signal and has the function of color separation.

The μ PD3799 has 3 rows of 5300 pixels, and each row has a single-sided readout type of charge transfer register. And it has reset feed-through level clamp circuits, clamp pulse generation circuit and voltage amplifiers. Therefore, it is suitable for 600 dpi/A4 color image scanners, color facsimiles and so on.

FEATURES

- Valid photocell : 5300 pixels × 3
- Photocell's pitch : 7 μ m
- Line spacing : 28 μ m (4 lines) Red line-Green line, Green line-Blue line
- Color filter : Primary colors (red, green and blue), pigment filter (with light resistance 10^7 lx•hour)
- Resolution : 24 dot/mm A4 (210 × 297 mm) size (shorter side)
600 dpi US letter (8.5" × 11") size (shorter side)
- Drive clock level : CMOS output under 5 V operation
- Data rate : 4 MHz MAX.
- Power supply : +12 V
- On-chip circuits : Reset feed-through level clamp circuits
Clamp pulse generation circuit
Voltage amplifiers

ORDERING INFORMATION

Part Number	Package
μ PD3799CY	CCD linear image sensor 32-pin plastic DIP (400 mil)

The information in this document is subject to change without notice. Before using this document, please confirm that this is the latest version.
Not all devices/types available in every country. Please check with local NEC representative for availability and additional information.

BLOCK DIAGRAM

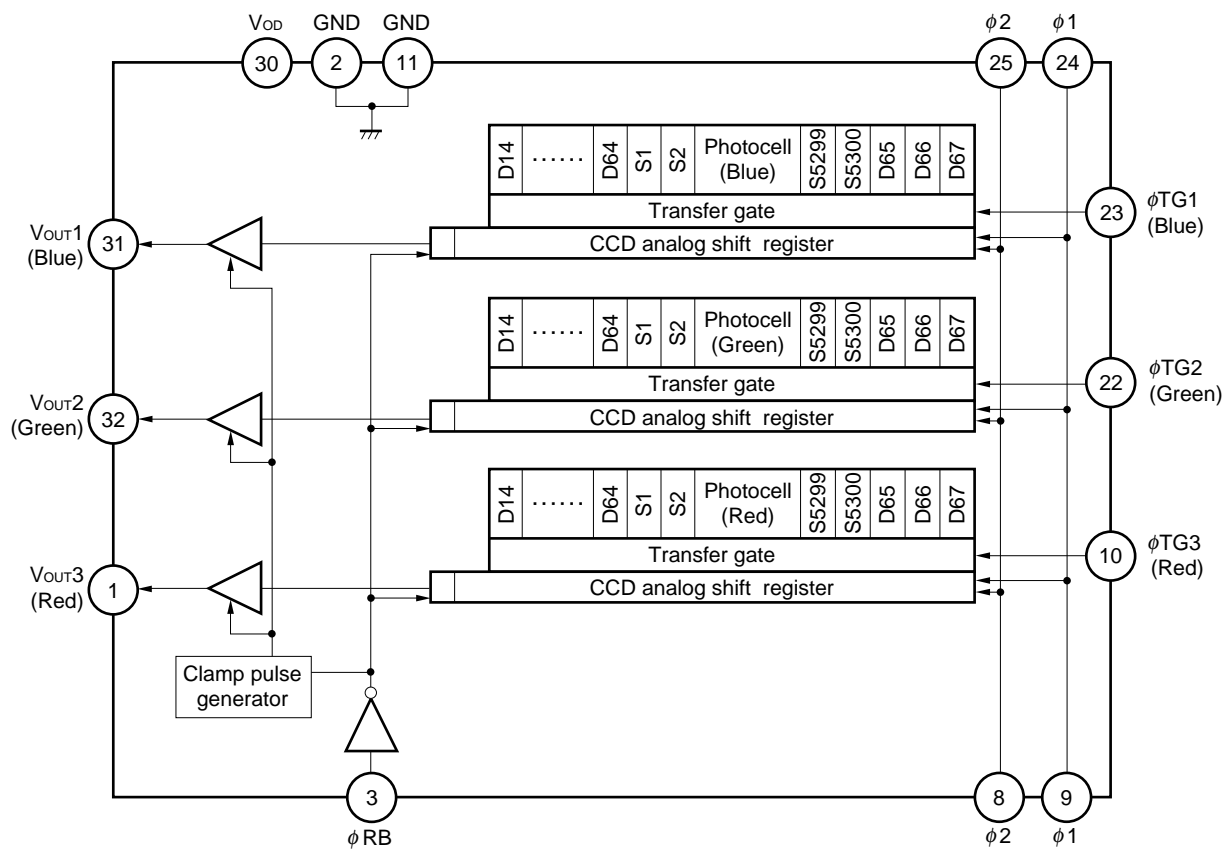

PIN CONFIGURATION (Top View)

CCD linear image sensor 32-pin plastic DIP (400 mil)

- μPD3799CY

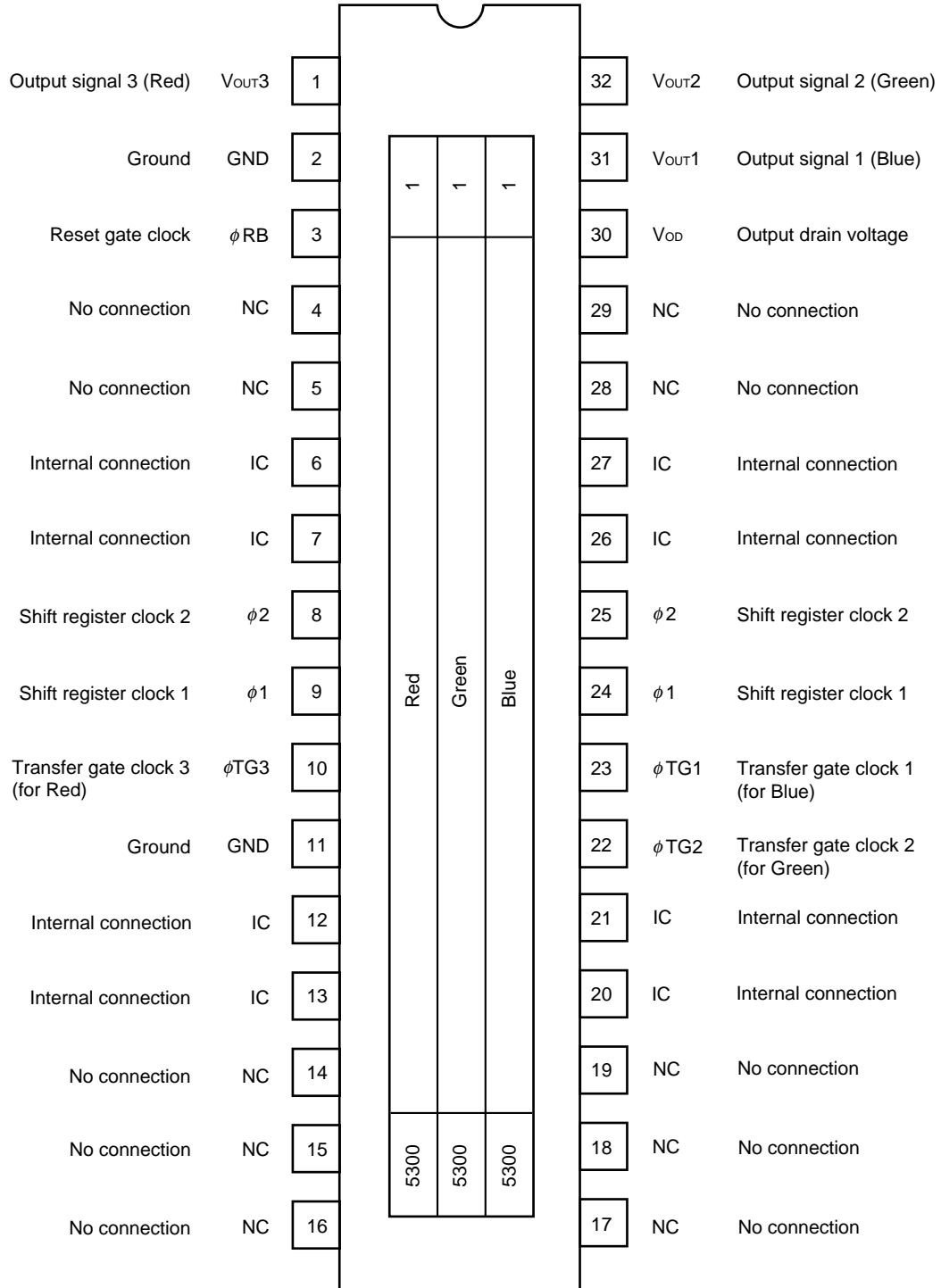

Caution Leave pins 6, 7, 12, 13, 20, 21, 26, 27 (IC) unconnected.

PHOTOCELL STRUCTURE DIAGRAM

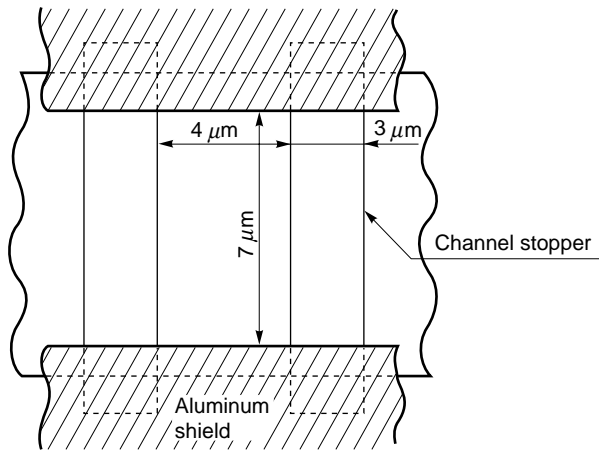

PHOTOCELL ARRAY STRUCTURE DIAGRAM
(Line spacing)

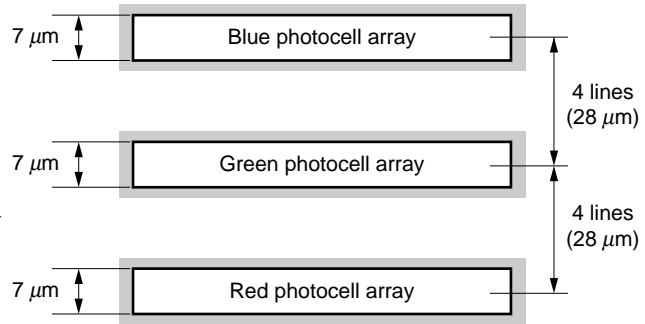

ABSOLUTE MAXIMUM RATINGS (T_A = +25 °C)

Parameter	Symbol	Ratings	Unit
Output drain voltage	V _{OD}	-0.3 to +15	V
Shift register clock voltage	V _{φ1} , V _{φ2}	-0.3 to +8	V
Reset gate clock voltage	V _{φRB}	-0.3 to +8	V
Transfer gate clock voltage	V _{φTG1} to V _{φTG3}	-0.3 to +8	V
Operating ambient temperature	T _A	-25 to +60	°C
Storage temperature	T _{stg}	-40 to +70	°C

Caution Exposure to ABSOLUTE MAXIMUM RATINGS for extended periods may affect device reliability; exceeding the ratings could cause permanent damage. The parameters apply independently.

RECOMMENDED OPERATING CONDITIONS (T_A = +25 °C)

Parameter	Symbol	MIN.	TYP.	MAX.	Unit
Output drain voltage	V _{OD}	11.4	12.0	12.6	V
Shift register clock high level	V _{φ1H} , V _{φ2H}	4.5	5.0	5.5	V
Shift register clock low level	V _{φ1L} , V _{φ2L}	-0.3	0	+0.5	V
Reset gate clock high level	V _{φRBH}	4.5	5.0	5.5	V
Reset gate clock low level	V _{φRBL}	-0.3	0	+0.5	V
Transfer gate clock high level	V _{φTG1H} to V _{φTG3H}	4.5	V _{φ1H} ^{Note}	V _{φ1H} ^{Note}	V
Transfer gate clock low level	V _{φTG1L} to V _{φTG3L}	-0.3	0	+0.5	V
Data rate	f _{φRB}	-	1.0	4.0	MHz

Note When Transfer gate clock high level (V_{φTG1H} to V_{φTG3H}) is higher than Shift register clock high level (V_{φ1H}), Image lag can increase.

ELECTRICAL CHARACTERISTICS

($T_A = +25\text{ }^\circ\text{C}$, $V_{OD} = 12\text{ V}$, data rate ($f_{\phi RB}$) = 1 MHz, storage time = 5.5 ms, input signal clock = 5 V_{p-p}
light source: 3200 K halogen lamp +C-500S (infrared cut filter, t = 1mm) + HA-50 (heat absorbing filter, t = 3 mm)

Parameter	Symbol	Test Conditions	MIN.	TYP.	MAX.	Unit
Saturation voltage	V_{sat}		2.0	2.5	–	V
Saturation exposure	Red	SER		0.223		lx•s
	Green	SEG		0.245		lx•s
	Blue	SEB		0.409		lx•s
Photo response non-uniformity	PRNU	$V_{OUT} = 1.0\text{ V}$		6	20	%
Average dark signal	ADS	Light shielding		0.2	2.0	mV
Dark signal non-uniformity	DSNU	Light shielding		1.5	3.0	mV
Power consumption	P_w			360	540	mW
Output impedance	Z_o			0.5	1	k Ω
Response	Red	R_R	7.8	11.2	14.6	V/lx•s
	Green	R_G	7.1	10.2	13.3	V/lx•s
	Blue	R_B	4.2	6.1	8.0	V/lx•s
Image lag	IL	$V_{OUT} = 1.0\text{ V}$		1.5	7.0	%
Offset level Note1	V_{os}		4.0	5.5	7.0	V
Output fall delay time Note2	t_d	$V_{OUT} = 1.0\text{ V}$		50		ns
Total transfer efficiency	TTE	$V_{OUT} = 1.0\text{ V}$, data rate = 4 MHz	92	98		%
Response peak	Red			630		nm
	Green			540		nm
	Blue			460		nm
Dynamic range	DR1	$V_{sat} / DSNU$		1666		times
	DR2	V_{sat} / σ		2500		times
Reset feed-through noise Note1	RFTN	Light shielding	–1000	–300	+500	mV
Random noise	σ	Light shielding	–	1.0	–	mV

Notes 1. Refer to **TIMING CHART 2**.

2. When the fall time of ϕ_1 (t_1) is the TYP. value (refer to **TIMING CHART 2**).

INPUT PIN CAPACITANCE ($T_A = +25\text{ }^\circ\text{C}$, $V_{OD} = 12\text{ V}$)

Parameter	Symbol	Pin name	Pin No.	MIN.	TYP.	MAX.	Unit
Shift register clock pin capacitance 1	$C_{\phi 1}$	$\phi 1$	9		400		pF
			24		400		pF
Shift register clock pin capacitance 2	$C_{\phi 2}$	$\phi 2$	8		400		pF
			25		400		pF
Reset gate clock pin capacitance	$C_{\phi RB}$	ϕRB	3		15		pF
Transfer gate clock pin capacitance	$C_{\phi TG}$	$\phi TG1$	23		100		pF
		$\phi TG2$	22		100		pF
		$\phi TG3$	10		100		pF

Remark Pins 9 and 24 ($\phi 1$), 8 and 25 ($\phi 2$) are each connected inside of the device.

TIMING CHART 1 (for each color)

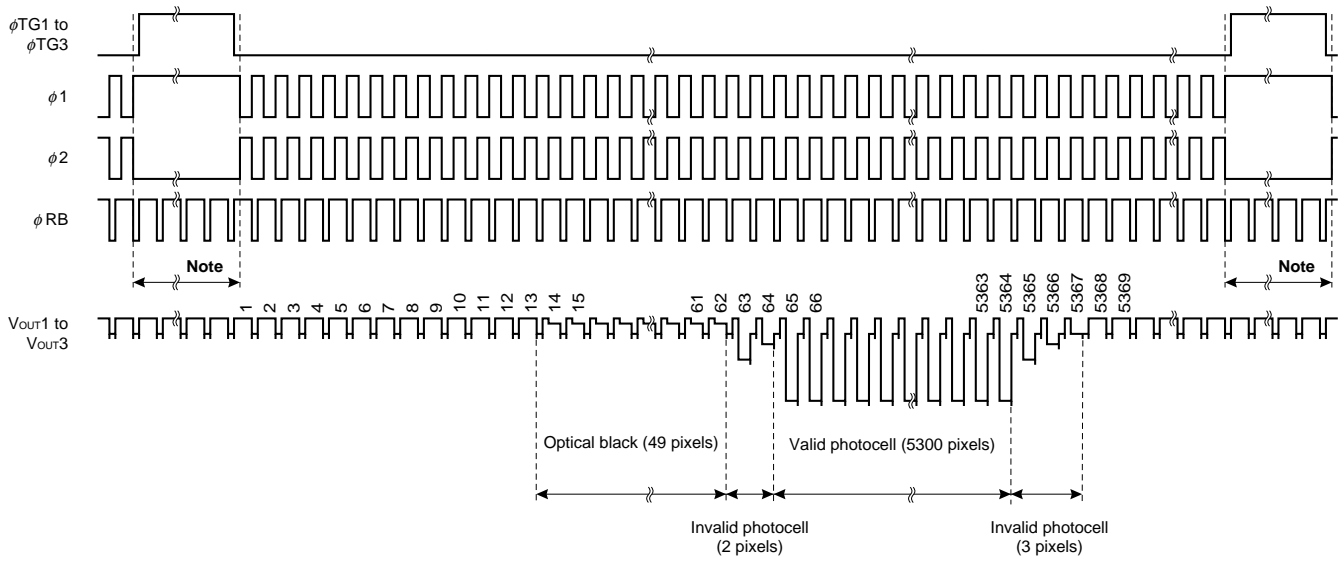

Note Input the ϕRB pulse continuously during this period, too.

TIMING CHART 2 (for each color)

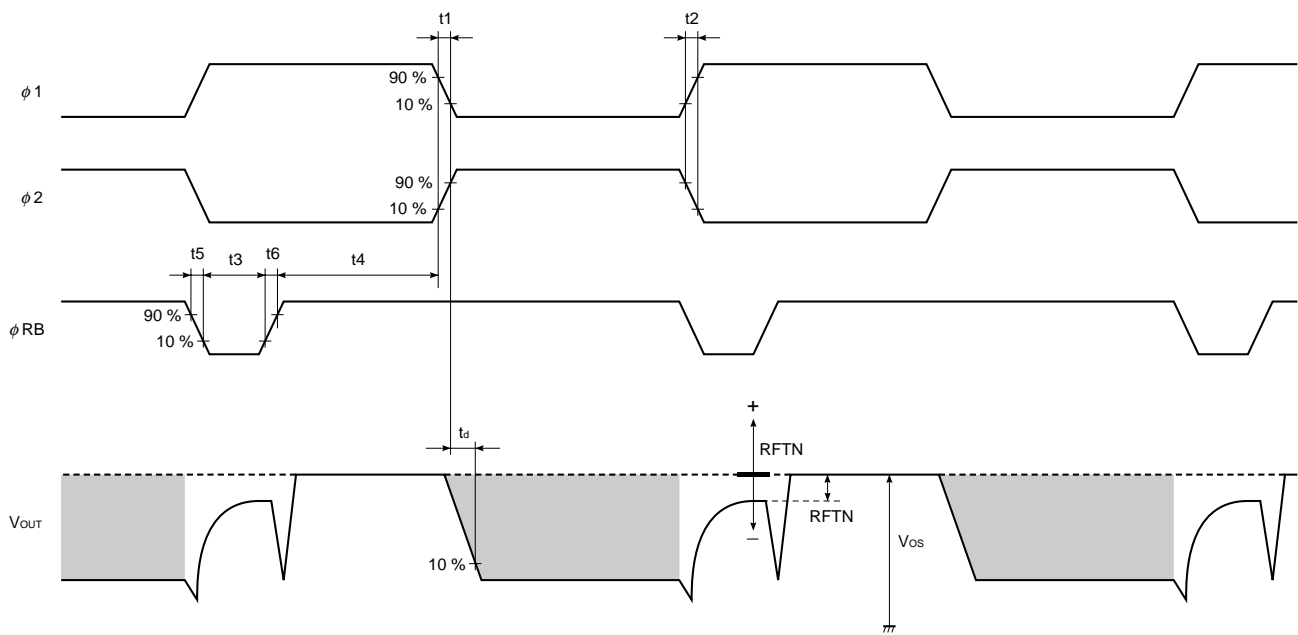

φTG1 to φTG3, φ1, φ2 TIMING CHART

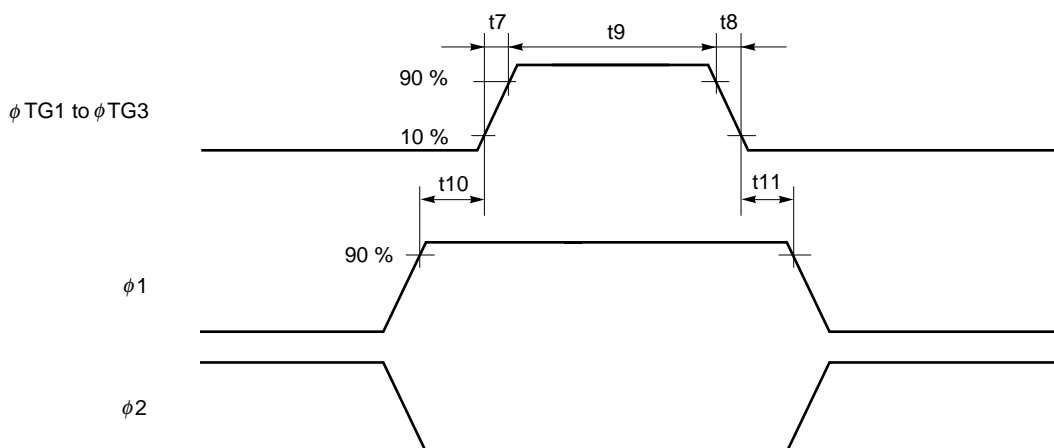

Symbol	MIN.	TYP.	MAX.	Unit
t1, t2	0	25	–	ns
t3	20	50	–	ns
t4	110	250	–	ns
t5, t6	0	25	–	ns
t7, t8	0	50	–	ns
t9	3000	10000	–	ns
t10, t11	900	1000	–	ns

φ1, φ2 cross points

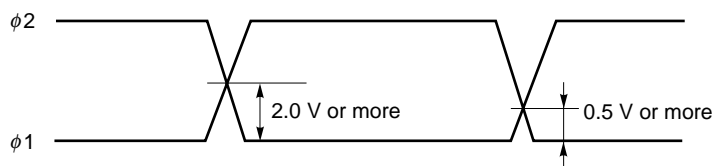

Remark Adjust cross points of φ1 and φ2 with input resistance of each pin.

DEFINITIONS OF CHARACTERISTIC ITEMS

1. Saturation voltage: V_{sat}
Output signal voltage at which the response linearity is lost.
2. Saturation exposure: SE
Product of intensity of illumination (lx) and storage time (s) when saturation of output voltage occurs.
3. Photo response non-uniformity: PRNU
The output signal non-uniformity of all the valid pixels when the photosensitive surface is applied with the light of uniform illumination. This is calculated by the following formula.

$$PRNU (\%) = \frac{\Delta x}{\bar{x}} \times 100$$

Δx : maximum of $|x_j - \bar{x}|$

$$\bar{x} = \frac{\sum_{j=1}^{5300} x_j}{5300}$$

x_j : Output voltage of valid pixel number j

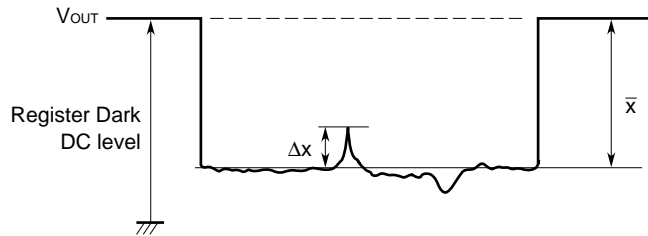

4. Average dark signal: ADS
Average output signal voltage of all the valid pixels at light shielding. This is calculated by the following formula.

$$ADS (mV) = \frac{\sum_{j=1}^{5300} d_j}{5300}$$

d_j : Dark signal of valid pixel number j

5. Dark signal non-uniformity: DSNU
Absolute maximum of the difference between ADS and voltage of the highest or lowest output pixel of all the valid pixels at light shielding. This is calculated by the following formula.

DSNU (mV) : maximum of $|d_j - ADS|_{j=1 \text{ to } 5300}$

d_j : Dark signal of valid pixel number j

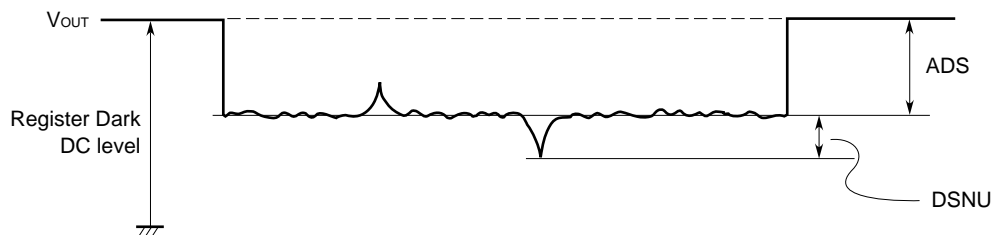

6. Output impedance: Z_o
Impedance of the output pins viewed from outside.

7. Response: R
Output voltage divided by exposure ($I \times s$).
Note that the response varies with a light source (spectral characteristic).

8. Image Lag: IL
The rate between the last output voltage and the next one after read out the data of a line.

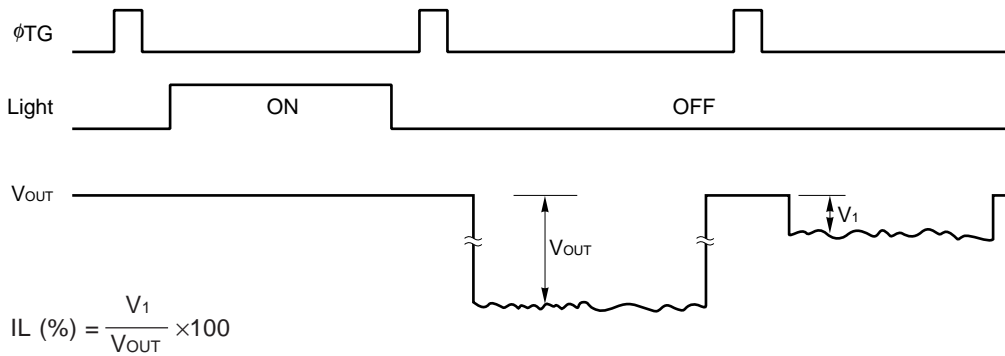

9. Random noise: σ
Random noise σ is defined as the standard deviation of a valid pixel output signal with 100 times (=100 lines) data sampling at dark (light shielding).

$$\sigma \text{ (mV)} = \sqrt{\frac{\sum_{i=1}^{100} (V_i - \bar{V})^2}{100}}, \quad \bar{V} = \frac{1}{100} \sum_{i=1}^{100} V_i$$

V_i : A valid pixel output signal among all of the valid pixels for each color

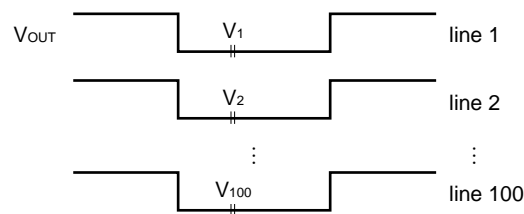

This is measured by the DC level sampling of only the signal level, not by CDS (Correlated Double Sampling).

STANDARD CHARACTERISTIC CURVES (Nominal)

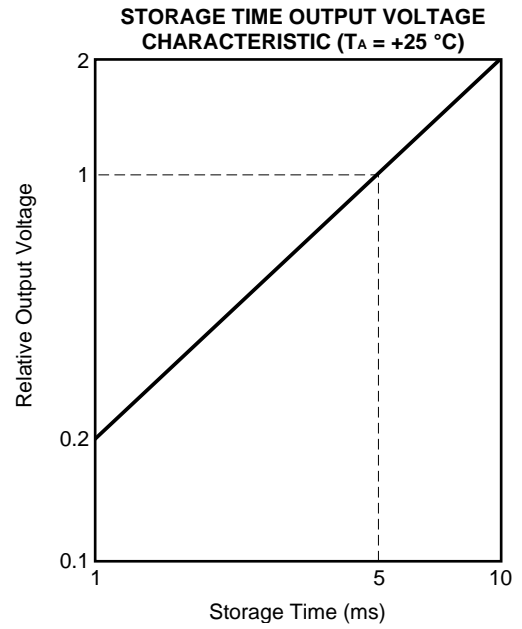
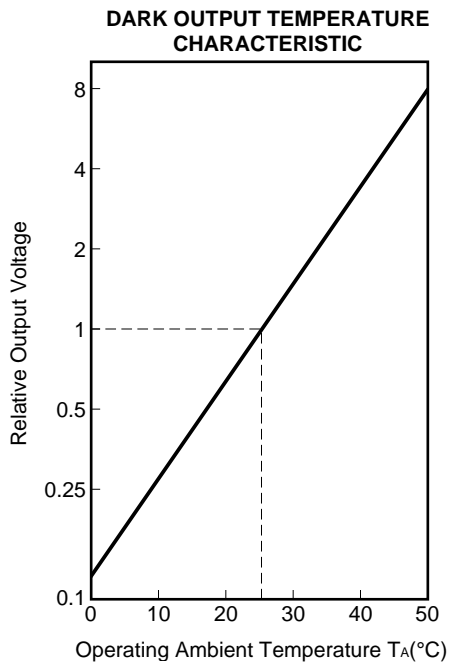

TOTAL SPECTRAL RESPONSE CHARACTERISTICS
(without infrared cut filter and heat absorbing filter) ($T_A = +25\text{ }^\circ\text{C}$)

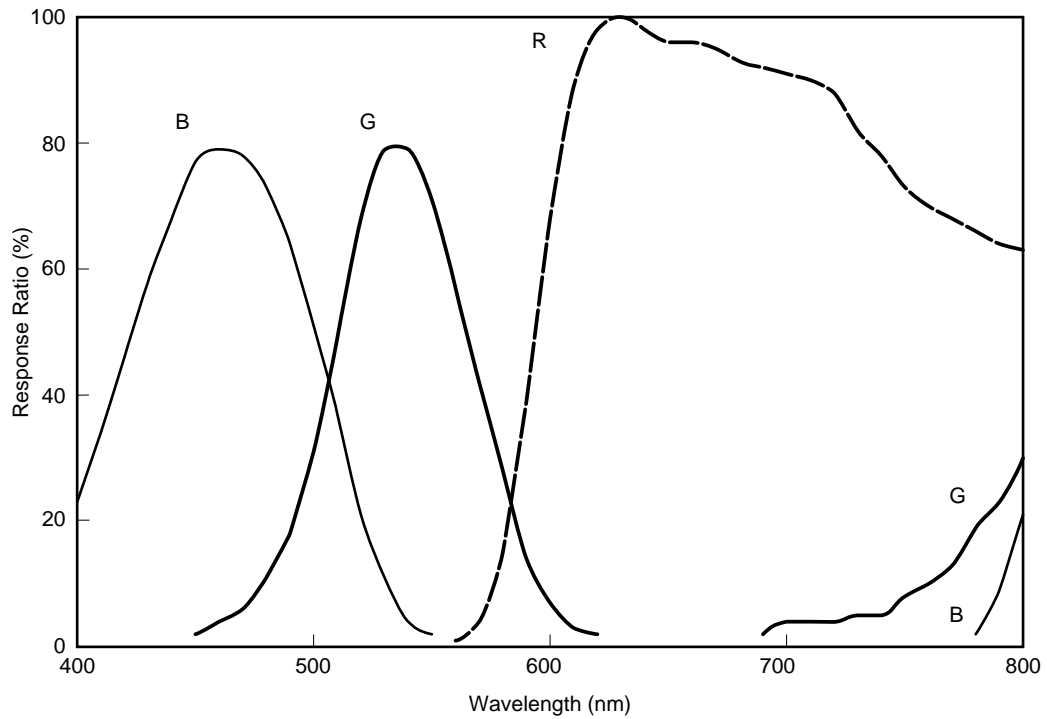

APPLICATION CIRCUIT EXAMPLE

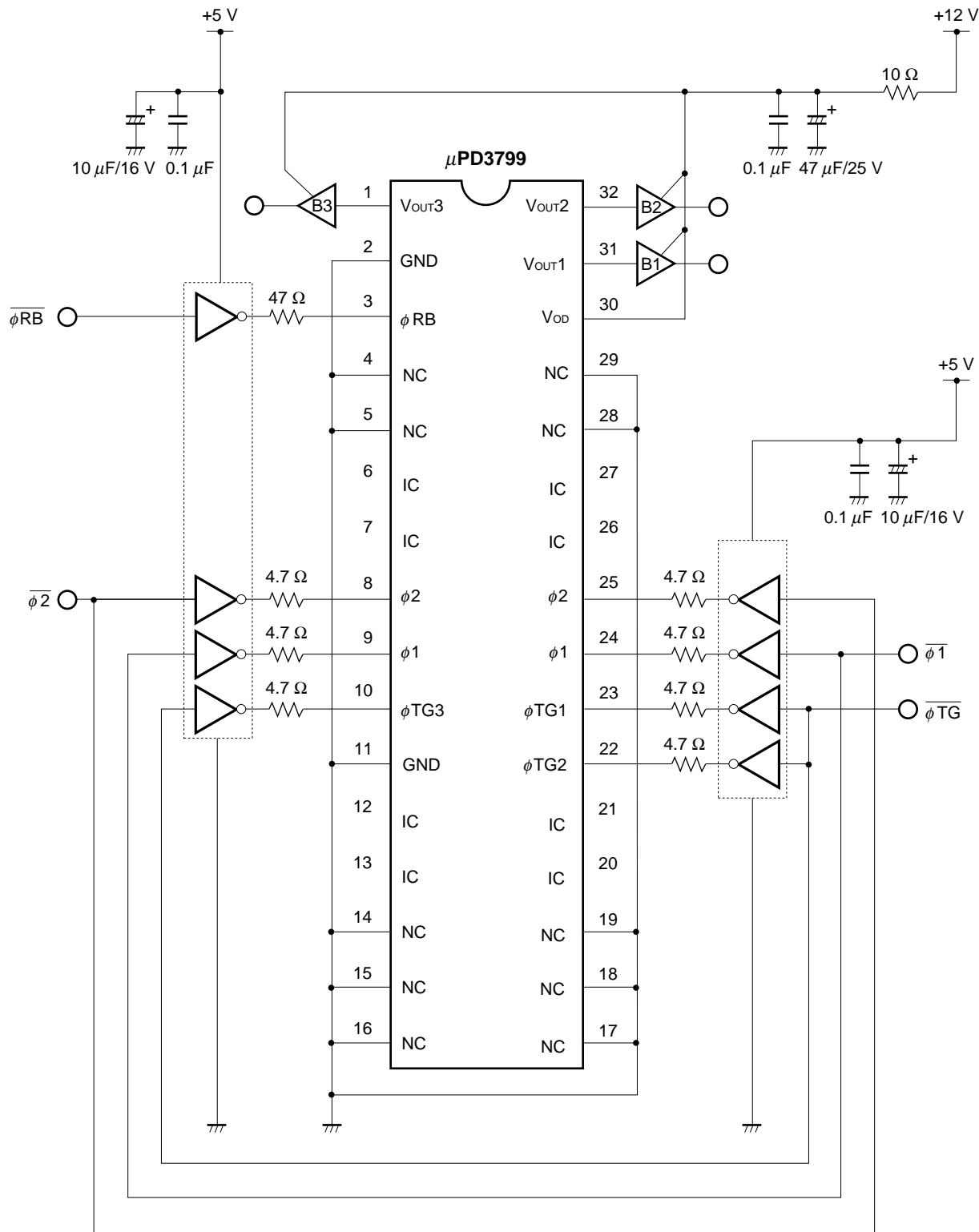

Caution Leave pins 6, 7, 12, 13, 20, 21, 26, 27 (IC) unconnected.

Remark The inverters shown in the above application circuit example are the 74HC04.

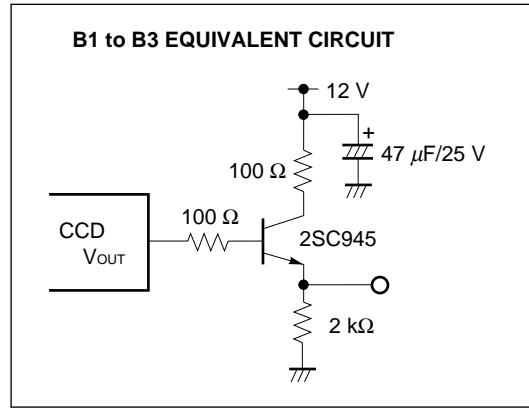

PACKAGE DRAWING

CCD LINEAR IMAGE SENSOR 32-PIN PLASTIC DIP (400 mil)
OUTLINE DRAWINGS (Unit : mm)

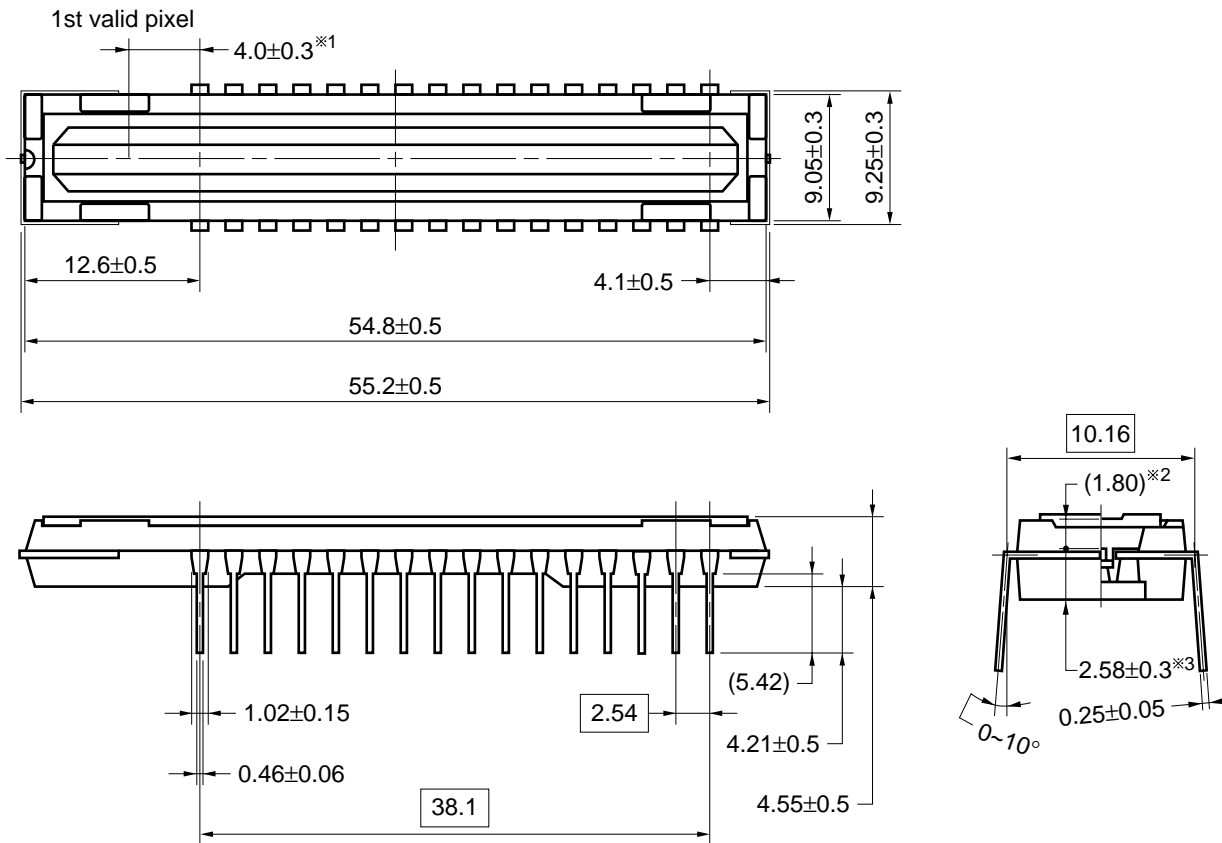

Name	Dimensions	Refractive index
Plastic cap	$52.2 \times 6.4 \times 0.7^{*4}$	1.5

- ※1 The 1st valid pixel ↔ The center of the pin1
- ※2 The surface of the chip ↔ The top of the cap
- ※3 The bottom of the package ↔ The surface of the chip
- ※4 Thickness of plastic cap over CCD chip

32C-1CCD-PKG1-1

RECOMMENDED SOLDERING CONDITIONS

When soldering this product, it is highly recommended to observe the conditions as shown below.

If other soldering processes are used, or if the soldering is performed under different conditions, please make sure to consult with our sales offices.

For more details, refer to our document "**Semiconductor Device Mounting Technology Manual**"(C10535E).

Type of Through-hole Device

μ PD3799CY : CCD linear image sensor 32-pin plastic DIP (400 mil)

Process	Conditions
Partial heating method	Pin temperature: 300 °C or below, Heat time: 3 seconds or less (per pin)

Caution During assembly care should be taken to prevent solder or flux from contacting the plastic cap.
The optical characteristics could be degraded by such contact.

NOTES ON CLEANING THE PLASTIC CAP

① CLEANING THE PLASTIC CAP

Care should be taken when cleaning the surface to prevent scratches.

The optical characteristics of the CCD will be degraded if the cap is scratched during cleaning.

We recommend cleaning the cap with a soft cloth moistened with one of the recommended solvents below. Excessive pressure should not be applied to the cap during cleaning. If the cap requires multiple cleanings it is recommended that a clean surface or cloth be used.

② RECOMMENDED SOLVENTS

The following are the recommended solvents for cleaning the CCD plastic cap. Use of solvents other than these could result in optical or physical degradation in the plastic cap. Please consult your sales office when considering an alternative solvent.

Solvents	Symbol
Ethyl Alcohol	EtOH
Methyl Alcohol	MeOH
Isopropyl Alcohol	IPA
N-methyl Pyrrolidone	NMP

NOTES FOR CMOS DEVICES

① PRECAUTION AGAINST ESD FOR SEMICONDUCTORS

Note:

Strong electric field, when exposed to a MOS device, can cause destruction of the gate oxide and ultimately degrade the device operation. Steps must be taken to stop generation of static electricity as much as possible, and quickly dissipate it once, when it has occurred. Environmental control must be adequate. When it is dry, humidifier should be used. It is recommended to avoid using insulators that easily build static electricity. Semiconductor devices must be stored and transported in an anti-static container, static shielding bag or conductive material. All test and measurement tools including work bench and floor should be grounded. The operator should be grounded using wrist strap. Semiconductor devices must not be touched with bare hands. Similar precautions need to be taken for PW boards with semiconductor devices on it.

② HANDLING OF UNUSED INPUT PINS FOR CMOS

Note:

No connection for CMOS device inputs can be cause of malfunction. If no connection is provided to the input pins, it is possible that an internal input level may be generated due to noise, etc., hence causing malfunction. CMOS devices behave differently than Bipolar or NMOS devices. Input levels of CMOS devices must be fixed high or low by using a pull-up or pull-down circuitry. Each unused pin should be connected to V_{DD} or GND with a resistor, if it is considered to have a possibility of being an output pin. All handling related to the unused pins must be judged device by device and related specifications governing the devices.

③ STATUS BEFORE INITIALIZATION OF MOS DEVICES

Note:

Power-on does not necessarily define initial status of MOS device. Production process of MOS does not define the initial operation status of the device. Immediately after the power source is turned ON, the devices with reset function have not yet been initialized. Hence, power-on does not guarantee out-pin levels, I/O settings or contents of registers. Device is not initialized until the reset signal is received. Reset operation must be executed immediately after power-on for devices having reset function.

[MEMO]

- **The information in this document is subject to change without notice. Before using this document, please confirm that this is the latest version.**
 - No part of this document may be copied or reproduced in any form or by any means without the prior written consent of NEC Corporation. NEC Corporation assumes no responsibility for any errors which may appear in this document.
 - NEC Corporation does not assume any liability for infringement of patents, copyrights or other intellectual property rights of third parties by or arising from use of a device described herein or any other liability arising from use of such device. No license, either express, implied or otherwise, is granted under any patents, copyrights or other intellectual property rights of NEC Corporation or others.
 - Descriptions of circuits, software, and other related information in this document are provided for illustrative purposes in semiconductor product operation and application examples. The incorporation of these circuits, software, and information in the design of the customer's equipment shall be done under the full responsibility of the customer. NEC Corporation assumes no responsibility for any losses incurred by the customer or third parties arising from the use of these circuits, software, and information.
 - While NEC Corporation has been making continuous effort to enhance the reliability of its semiconductor devices, the possibility of defects cannot be eliminated entirely. To minimize risks of damage or injury to persons or property arising from a defect in an NEC semiconductor device, customers must incorporate sufficient safety measures in its design, such as redundancy, fire-containment, and anti-failure features.
 - NEC devices are classified into the following three quality grades:
"Standard", "Special", and "Specific". The Specific quality grade applies only to devices developed based on a customer designated "quality assurance program" for a specific application. The recommended applications of a device depend on its quality grade, as indicated below. Customers must check the quality grade of each device before using it in a particular application.
 - Standard: Computers, office equipment, communications equipment, test and measurement equipment, audio and visual equipment, home electronic appliances, machine tools, personal electronic equipment and industrial robots
 - Special: Transportation equipment (automobiles, trains, ships, etc.), traffic control systems, anti-disaster systems, anti-crime systems, safety equipment and medical equipment (not specifically designed for life support)
 - Specific: Aircraft, aerospace equipment, submersible repeaters, nuclear reactor control systems, life support systems or medical equipment for life support, etc.
- The quality grade of NEC devices is "Standard" unless otherwise specified in NEC's Data Sheets or Data Books. If customers intend to use NEC devices for applications other than those specified for Standard quality grade, they should contact an NEC sales representative in advance.

M7 98.8