

Programmable seven-channel RC encoder

NE5044

DESCRIPTION

The NE5044 is a programmable parallel input, serial output pulse width encoder. A multiplexed dual linear ramp technique is used to allow up to 7 inputs to be converted to a serial pulse width modulated signal with excellent linearity and minimal crosstalk. Fixed or variable frame rates can be used, externally controlled, for ease of demodulation. An on-board 5V regulator eliminates power supply sensitivities and provides up to 20mA current capability for driving external loads.

FEATURES

- 3 to 7 channels, externally selectable
- Constant-current dual linear ramp for linearity better than 0.3%
- Internal voltage regulator for low drift
- Wide supply range 4.5-12V
- Fixed or variable frame rate set by external RC
- External control for channel gain or range
- Versatile applications: exponential rates, mixing, dual rate, reversing, etc.
- Compatible with all transmission mediums

APPLICATIONS

- Radio-controlled aircraft, cars, boats, trains

PIN CONFIGURATION

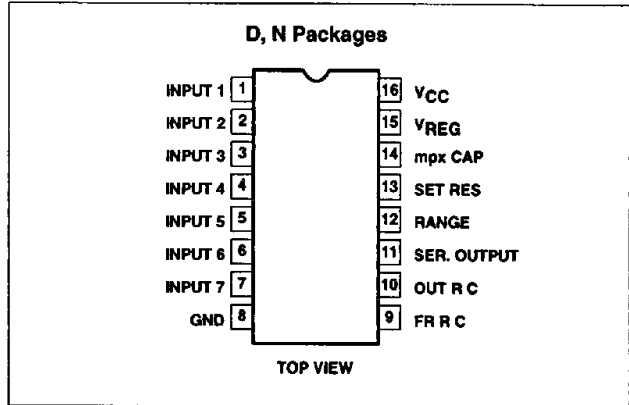

- Industrial controllers
- Remote-controlled entertainment systems
- Security systems
- Instrumentation recorders/controls
- Remote analog/digital data transmission
- Automotive sensor systems
- Robotics
- Telemetry

BLOCK DIAGRAM

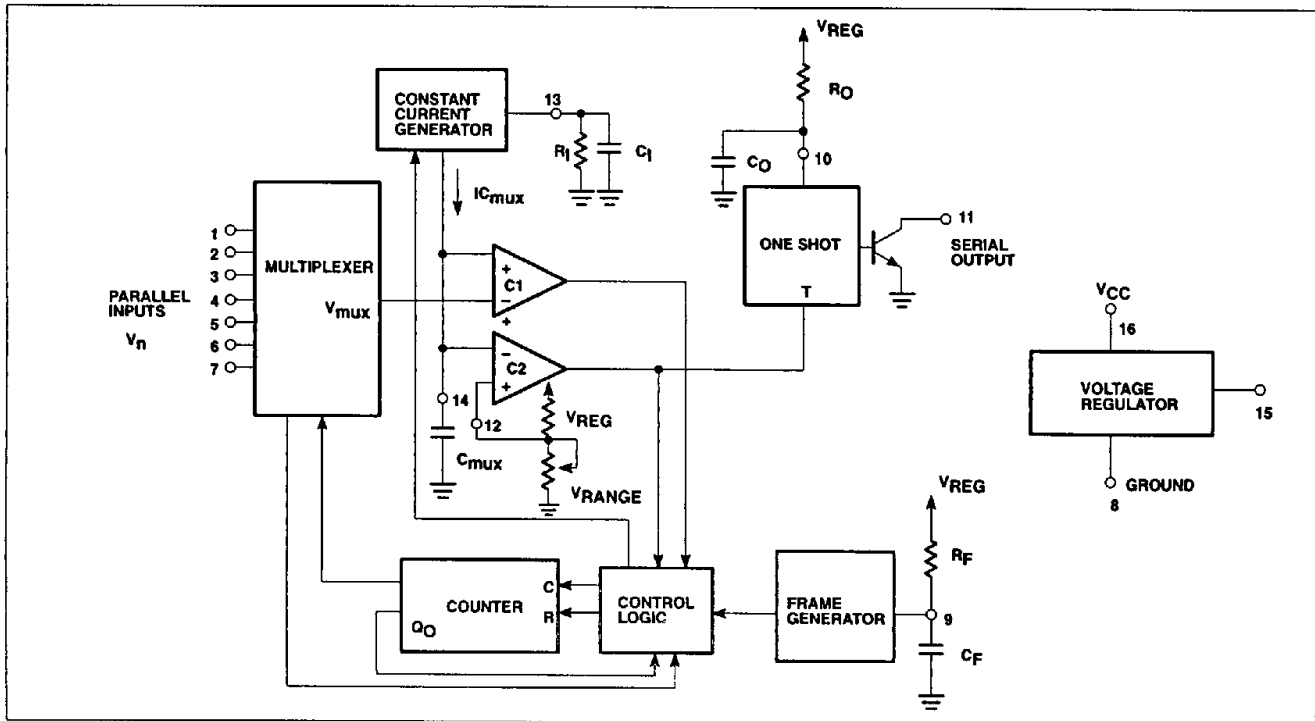

Programmable seven-channel RC encoder

NE5044

ORDERING INFORMATION

| DESCRIPTION | TEMPERATURE RANGE | ORDER CODE | DWG # |
|---|-------------------|------------|-------|
| 16-Pin Plastic Small Outline (SO) Package | 0 to +70°C | NE5044D | 0005D |
| 16-Pin Plastic Dual In-Line Package (DIP) | 0 to +70°C | NE5044N | 0406C |

ABSOLUTE MAXIMUM RATINGS¹

| SYMBOL | PARAMETER | RATING | UNIT |
|------------------|---------------------------------------|--------------------|------|
| V _{CC} | Supply voltage | 13 | V |
| I _{OUT} | Regulator output current | -25 | mA |
| | Serial output peak current | 30 | mA |
| | Constant-current generator | -1 | mA |
| | Parallel inputs, range input | 0-V _{REG} | V |
| | One-shot input, frame generator input | 0-V _{REG} | V |
| T _A | Operating temperature range | 0 to +70 | °C |
| T _{STG} | Storage temperature range | -65 to +150 | °C |

NOTE:

1. T_A=25°C, unless otherwise stated.

DC ELECTRICAL CHARACTERISTICS

Test Conditions T_A = 25°C V_{CC}=10V using Test Circuit, unless otherwise stated.

| SYMBOL | PARAMETER | TEST CONDITIONS | LIMITS | | | UNIT |
|----------------------------------|----------------------------|---|--------|-------|------|------|
| | | | Min | Typ | Max | |
| Power supply requirements | | | | | | |
| V _{CC} | Power supply voltage range | | 4.5 | | 12 | V |
| I _{CC} | Power supply current | Excluding control pots and serial output currents | | 11 | 15 | mA |
| Voltage regulator | | | | | | |
| V _{REG} | Output voltage | | 4.5 | 5.0 | 5.5 | V |
| I _{OUT} | Output current | V _R ≥4.5V | | | -20 | mA |
| | Line regulation | 7≤V _{CC} ≤12 | | 0.005 | 0.02 | V/V |
| Multiplexer | | | | | | |
| I _{IN} | Input current | V _n =2.5V | | ±30 | ±200 | nA |
| V _{IN} | Input voltage range | V _n -V _{Range} ≥0.75V | 1.5 | | 5 | V |
| | Crosstalk | | | ±1 | ±5 | µs |

Programmable seven-channel RC encoder

NE5044

AC ELECTRICAL CHARACTERISTICS

Test conditions $T_A=25^\circ\text{C}$, $V_{CC}=10\text{V}$ using Test Circuit, unless otherwise stated.

| SYMBOL | PARAMETER | TEST CONDITIONS | LIMITS | | | UNIT |
|---------------------|--------------------------|--|--------|------|------|------------------------------|
| | | | Min | Typ | Max | |
| Output pulse | | | | | | |
| t_n | Position | $R_I \cdot C_{MUX}=1.25\text{ms}$ $V_n=0.5V_{REG}$; $V_{RANGE}=0.2V_{REG}$ | 1350 | 1500 | 1650 | μs |
| | Position linearity error | | | 5 | | μs |
| | Position tempco | $0^\circ\text{C} \leq T_A \leq 70^\circ\text{C}$ | | 0.15 | | $\mu\text{s}/^\circ\text{C}$ |
| | Position PSR | $6\text{V} \leq V_{CC} \leq 12\text{V}$ | | 0.5 | 1 | $\mu\text{s}/\text{V}$ |
| t_o | Width | $R_O C_O=300\mu\text{s}$ | 240 | 285 | 330 | μs |
| | Saturation voltage | $I_O=25\text{mA}$ | | 0.6 | 1 | V |
| I_{11} | Leakage current | | | 0.05 | 50 | μA |
| R_I | Range input voltage | $R_I=50\text{k}\Omega$ | 0.75 | | | V |
| | | $R_I=25\text{k}\Omega$ | 1.00 | | | V |
| | Frame time (fixed) | $R_F C_F=30\text{ms}$ | 17 | 20 | 23 | ms |
| | Inhibit threshold | | | | 0.4 | V |

TYPICAL PERFORMANCE CHARACTERISTICS

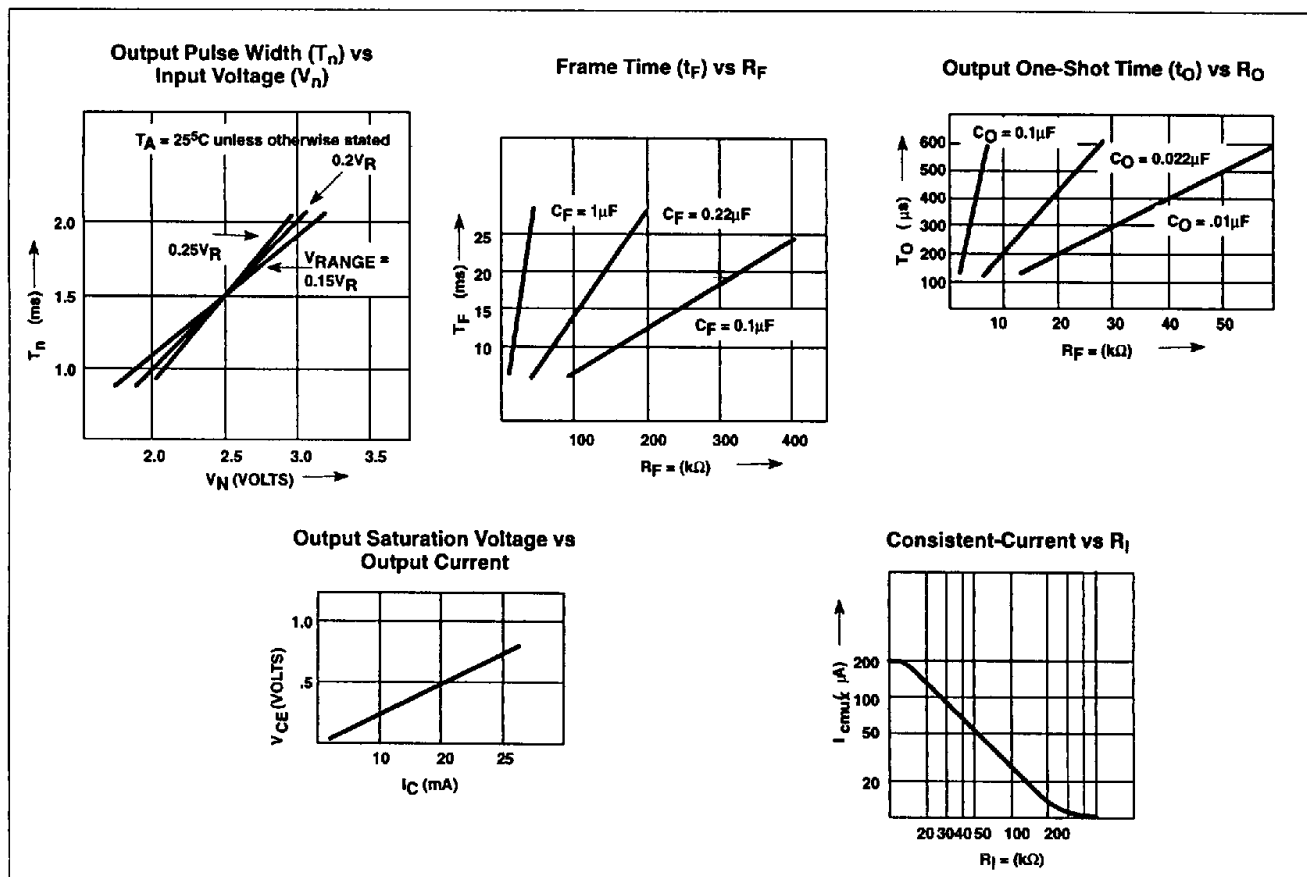

Programmable seven-channel RC encoder

NE5044

TEST CIRCUIT

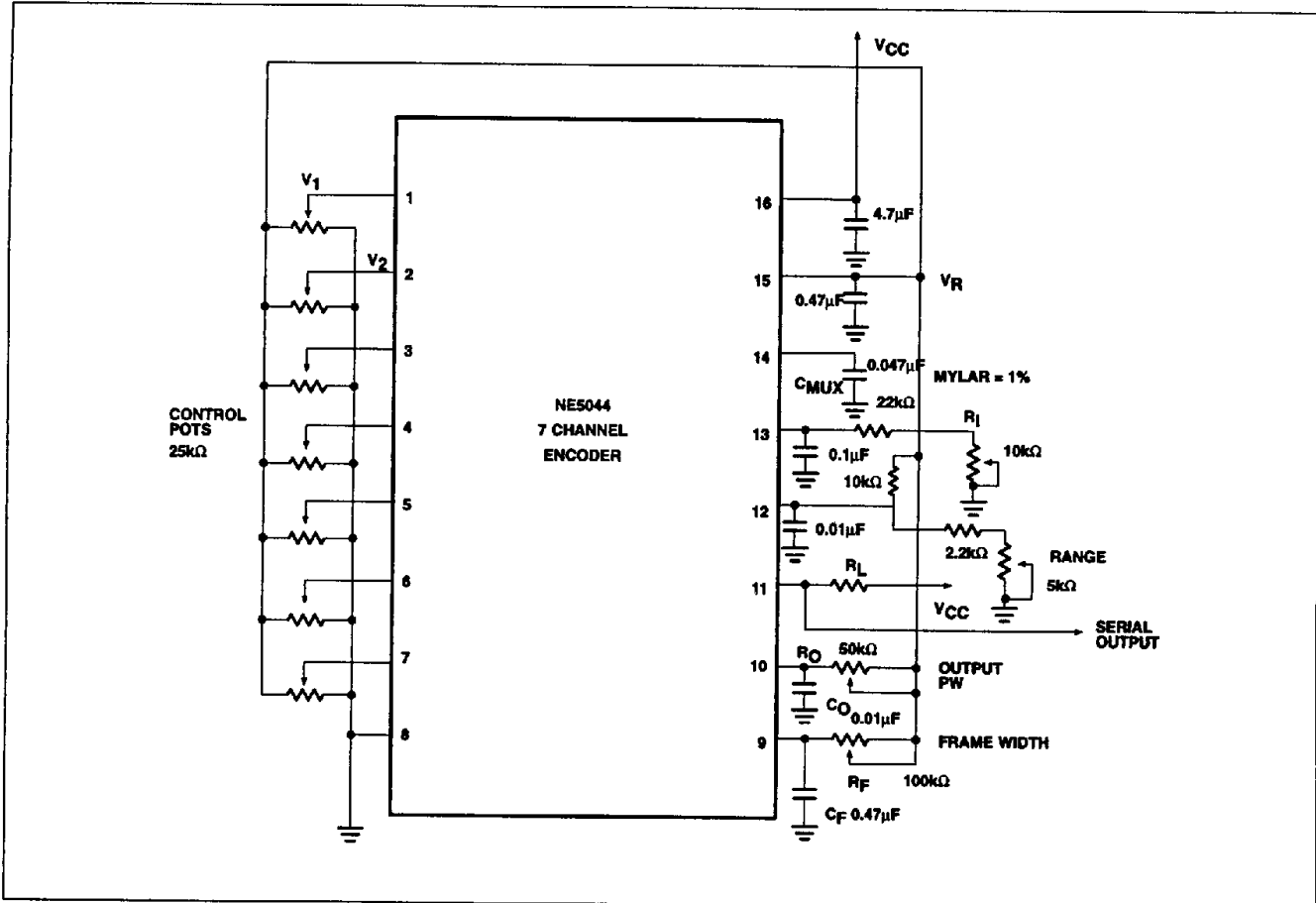

CIRCUIT OPERATION

The NE5044 is a programmable parallel input, serial output encoder containing all the active circuitry necessary to generate a precise pulse width modulated signal with 3 to 7 channels. The number of channels is externally programmable by grounding unused control inputs. A multiplexed dual linear ramp technique is used to provide excellent linearity, minimal crosstalk and low temperature drift. An on-board 5V regulator eliminates power supply sensitivities and has up to 20mA current capability for driving external loads. The encoder can be used in the fixed-frame mode or, with the addition of one external NPN transistor, as a variable-frame encoder.

The multiplexer functions as a strobed voltage-follower so that each input, when active, appears as a high-impedance input (>1MΩ) and transfers the input voltage to the output. Only one of the seven inputs is active at any time and when a given input is inactive, it appears as an open circuit. The high-impedance multiplexer inputs eliminate loading on control inputs and simplify mixing circuits where several controls may be mixed onto one input.

Channel 4, 5, 6 and 7 inputs may also be used to select the desired number of output pulses by grounding one or more of these pins. That is, by grounding Pin 4 (Channel 4 input) only the first three inputs of the encoder will be used and a 3-channel encoder results. Grounding Pin 5 results in a 4-channel encoder, and so on. Thus, any number of channels between 3 and 7 may be selected. Internal voltage clamping prevents encoder malfunction if any input is shorted to supply, ground or open-circuited. The remaining channels will continue to be encoded except as noted above. This feature

eliminates catastrophic failures due to control pot open- or short-circuits.

The constant-current generator is a bidirectional current source whose current is set by an external resistor R_I , where:

$$I_C = \pm \frac{V_R}{2R_I}$$

The current generator alternately charges and discharges the capacitor C_{MUX} . An internal feedback loop maintains a constant current and very high output impedance. This yields a typical linearity error of voltage input to pulse width output for the encoder of less than 0.1%. An external capacitor, C_1 , is required to insure stability of the feedback loop.

Two high gain comparators, C1 and C2, compare the voltage across C_{MUX} with the multiplexer output voltage and the range input voltage. The input bias currents and offset voltages of these comparators are sufficiently low so as to not influence the overall accuracy of the encoder. The comparators feed the counter control logic which in turn controls the counter and current generator. The operation of this loop is as follows: When I_C is positive (sourced from the current generator into C_{MUX}) the capacitor linearly charges up until it reaches a voltage equal to the multiplexer output voltage; assume this to be the voltage at Pin 1, V_1 . At this time the output of C1 goes high, which reverses the direction of I_C (sinking into current generator from C_{MUX}). C_{MUX} now linearly discharges until it reaches the voltage set on Pin 12, V_{RANGE} . At this time the output of C2 goes high, which again reverses the polarity of I_C , clocks the

Programmable seven-channel RC encoder

NE5044

counter, and triggers the output one-shot. C_{MUX} again charges up but now C1 goes high when C_{MUX} reaches V2, the voltage on Pin 2. The resulting voltage waveform on C_{MUX} is a triangle wave whose positive peaks correspond to the voltages on Pins 1 through 7 for the first through seventh peaks and whose negative peaks are constant and equal to V_{RANGE} . This waveform is shown in the first portion of Figure 1.

Independent control of I_C and V_{RANGE} allows the encoder to be tailored to virtually any combination of input voltage changes and output pulse width changes. The functional relationships between these variables will be defined in the next section.

The frame generator controls the encoder frame time. It can operate as an astable or monostable multivibrator whose period is $0.66 \times R_F \times C_F$. The encoder will generate a synchronizing pulse at the end of each frame. When C_{MUX} reaches the seventh positive peak it reverses and discharges to V_{RANGE} . The counter is clocked to the state where Q_0 is high when $V_{CMUX} = V_{RANGE}$. C_{MUX} again charges up, but now the output of C1 is ignored, due to Q_0 being high, and charges up to V_{CLAMP} and remains there. The encoder will remain in this state until a pulse from the frame generator is received. If R_F and C_F are connected as shown in the Block Diagram, then the frame generator operates in the astable mode, producing a narrow pulse output. This pulse allows C_{MUX} to start discharging again. When C_{MUX} reaches V_{RANGE} , the counter is clocked to the state where Q_1 is high (channel 1) and the entire process starts over. The frame period in this mode is $0.66 \times R_F \times C_F$ and is referred to as the fixed-frame mode. The variable-frame mode will be discussed in the application section.

The output one-shot generates a positive pulse whose width is equal to $R_0 C_0$. The output is an open-collector, NPN transistor capable of sinking 25mA. This configuration allows the encoder to drive a wide variety of RF stages as well as providing current pulses in 2-wire communications applications.

ENCODER DESIGN EQUATIONS

The triangular waveform on C_{MUX} has a fixed slope (constant current) and variable positive peak voltages. The time between the negative peaks of C_{MUX} , which is equal to the output period for that channel, is given by:

$$t_n = \frac{2 (V_n - V_{RANGE}) C_{MUX}}{I_C}$$

I_C is given by:

$$I_C = \frac{V_R}{2R_1}$$

where $V_R = \text{Reference Voltage}$.

Additionally, V_n , the voltage on Pin n, which is the control voltage for Channel n, is typically the wiper voltage on a pot connected between V_R and ground. Thus $V_n = X_n V_R$.

V_{RANGE} is also derived from V_R so that $V_{RANGE} = Y V_R$. The resulting channel time period is:

$$t_n = \frac{2 (X_n - Y) V_R \cdot C_{MUX}}{(V_R / 2R_1)}$$

$$t_n = 4R_1 C_{MUX} (X_n - Y)$$

Thus, each channel pulse width, t_n , is independent of supply voltage and depends only on external passive components.

The conversion rate, CR, for each channel is the change in output period, Δt_n , divided by the change in input voltage for that channel, ΔV_n .

$$CR = \frac{\Delta t_n}{\Delta V_n} = \frac{\Delta t_n}{\Delta X_n} = 4 R_1 C_{MUX}$$

In most applications, the input variable X_n will have some neutral or center value about which it will vary, thus $X_n = X_0 + X_n$,

and

$$CR = \frac{\Delta t_n}{\Delta X_n} = 4R_1 C_{MUX}$$

Where X_0 is the neutral value for X and is assumed to be the same for all n. Now

$$t_n = 4R_1 C_{MUX} (X_0 - Y + X_n)$$

If we let $t_{NEUTRAL} = 4R_1 C_{MUX} (X_0 - Y)$ be the neutral value for t_n , then

$$t_n = t_{NEUTRAL} + 4R_1 C_{MUX} (X_n)$$

Consider the following example to see how these design equations are used.

Assume:

$$t_{NEUTRAL} = 1.5\text{ms}$$

$$X_0 = 0.5 \text{---Control pot in center at}$$

$$t_n = t_{NEUTRAL}$$

$\Delta X_n = \pm 0.1$ ---Control pot resistance varies $\pm 10\%$ (of total resistance) around neutral. This should include mechanical trim if used.

$$\Delta t_n = \pm 0.5\text{ms}$$

For this example, the conversion rate is

$$CR = \frac{\Delta t_n}{\Delta X_n} = \frac{0.5\text{ms}}{0.1} = 5\text{ms}$$

so

$$4R_1 C_{MUX} = 5\text{ms.}$$

If we let $C_{MUX} = 0.047\mu\text{F}$ then

$$R_1 = \frac{5\text{ms}}{4 \times 0.047\mu\text{F}} = 26.5\text{k}\Omega = 27\text{k}\Omega$$

and

$$t_{NEUTRAL} = 1.5\text{ms} = 4R_1 C_{MUX} (X_0 - Y)$$

$$Y = 0.5 - \frac{1.5\text{ms}}{5\text{ms}} = 0.2$$

The output pulse width is given by

$$t_0 = R_0 C_0$$

so if $t_0 = 330\mu\text{s}$ and $C_0 = 0.01\mu\text{F}$ then

Programmable seven-channel RC encoder

NE5044

$$R_O = \frac{330\mu s}{0.01\mu F} = 33k\Omega$$

The frame time constant, t_F is given by

$$t_F = 0.66 R_F C_F$$

If $t_F = 20ms$ and $C_F = 0.47\mu F$

$$R_F = \frac{20ms}{0.66 \times 0.47\mu F} = 62k$$

Figure 2 shows the external connections for this example.

It should be noted that the temperature stability of all the encoded times depend on the temperature coefficients of the respective external R_C time constants. No internal temperature compensation is used on the chip. The typical temperature sensitivity of t_n using wirewound resistors and polycarbonate capacitors is less than 100ppm/°C in the -20°C to +70°C temperature range. For the above example, this corresponds to a change in t_n of $\pm 7.5\mu s$ for a change in temperature of $\pm 50^\circ C$.

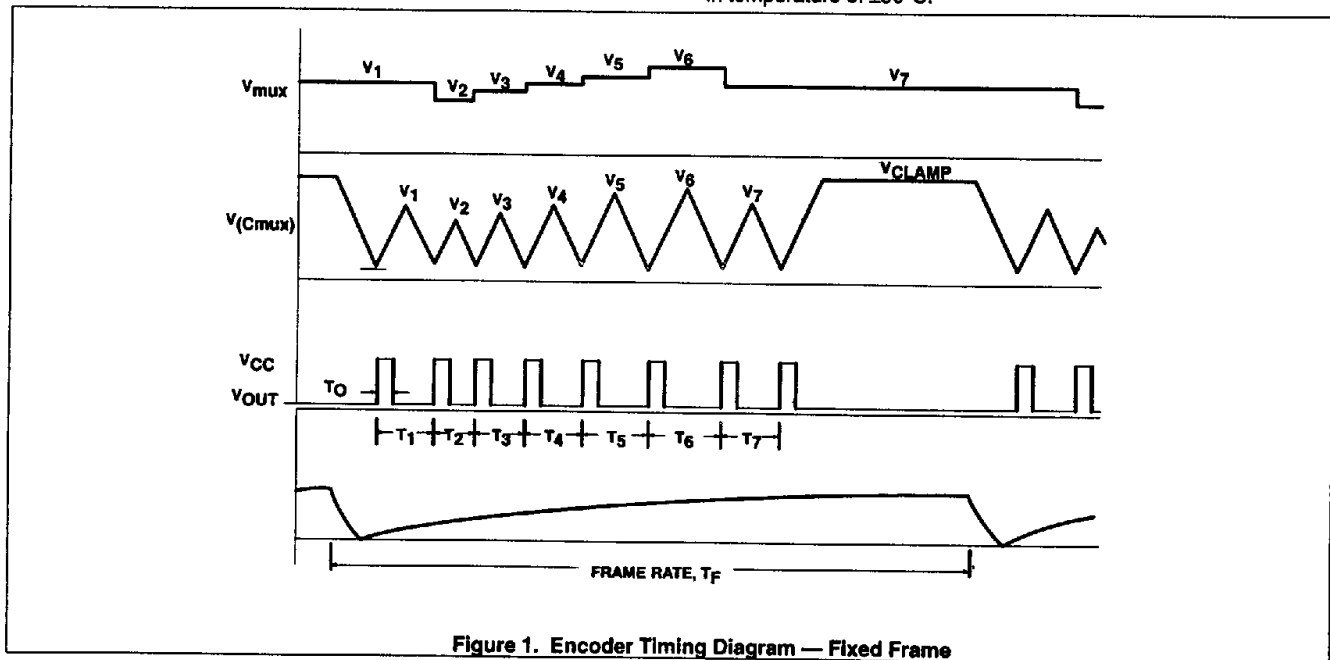

Figure 1. Encoder Timing Diagram — Fixed Frame

Programmable seven-channel RC encoder

NE5044

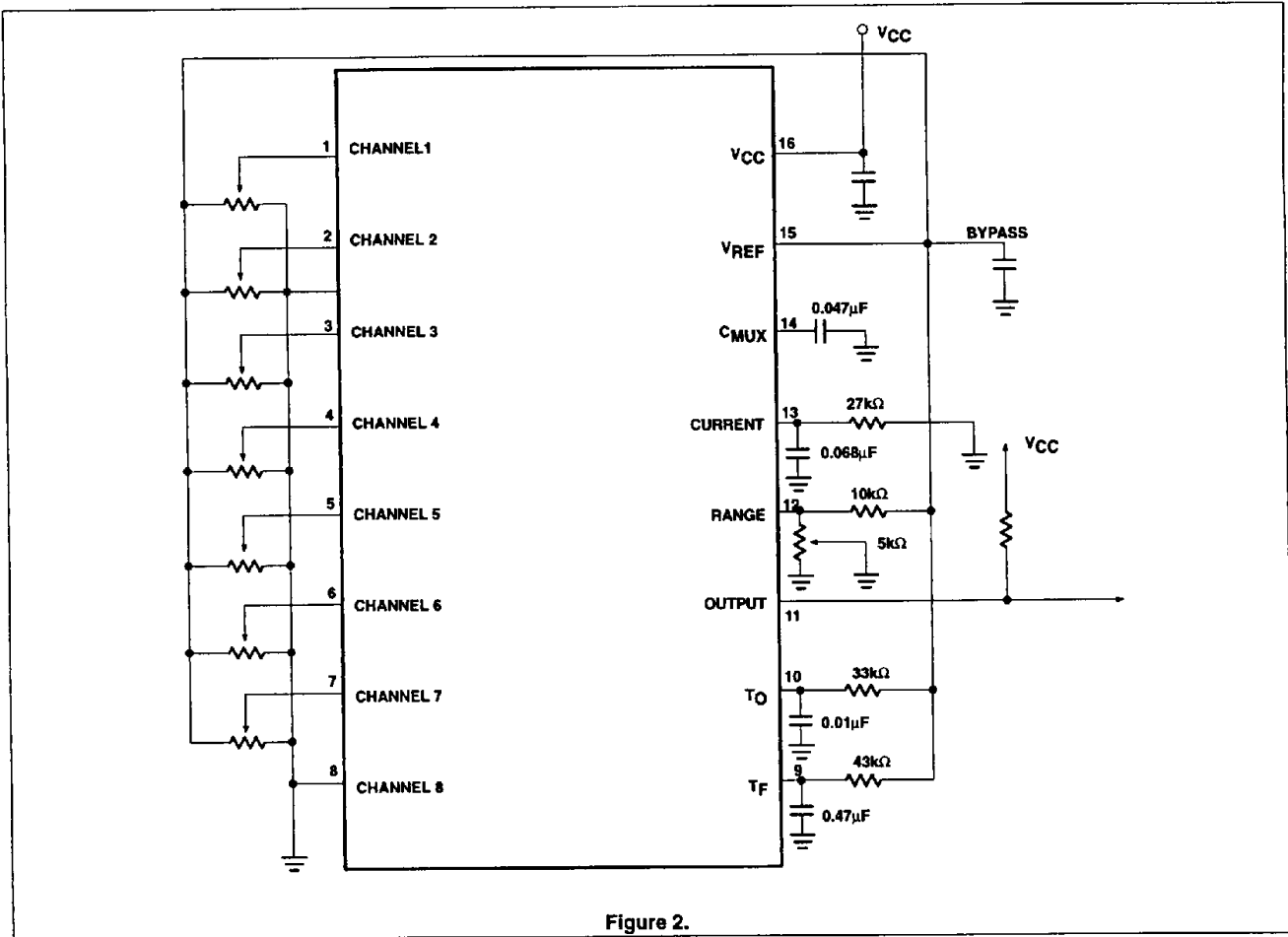

Figure 2.