

## Tire Pressure Monitoring (TPM) System

*Authors: Ruan Lourens  
Microchip Technology Inc.  
Curtis Kell  
Kell Laboratories*

An auto-location system can dynamically detect the position of a specific sensor, which is useful when tires are rotated. The heart of the TPM system is the Sensor/Transmitter (S/TX) device and it is based on Microchip's rfPIC12F675.

### INTRODUCTION

This document explains a typical tire pressure monitoring (TPM) system specifically intended for automotive use. It serves as a reference to design a real-world system based on various Microchip products. A TPM system primarily monitors the internal temperature and pressure of an automobile's tire. There is a variety of system approaches to follow, although this one is a rather comprehensive auto-location system.

### SYSTEM COMPONENTS

The TPM system consists of the following major component.

- Sensor/Transmitter Device
- RF Receiver Module
- Low Frequency (LF) Commander Device
- Control Unit
- Pressure Vessel (Tire)

**FIGURE 1: TIRE PRESSURE MONITORING (TPM) SYSTEM**

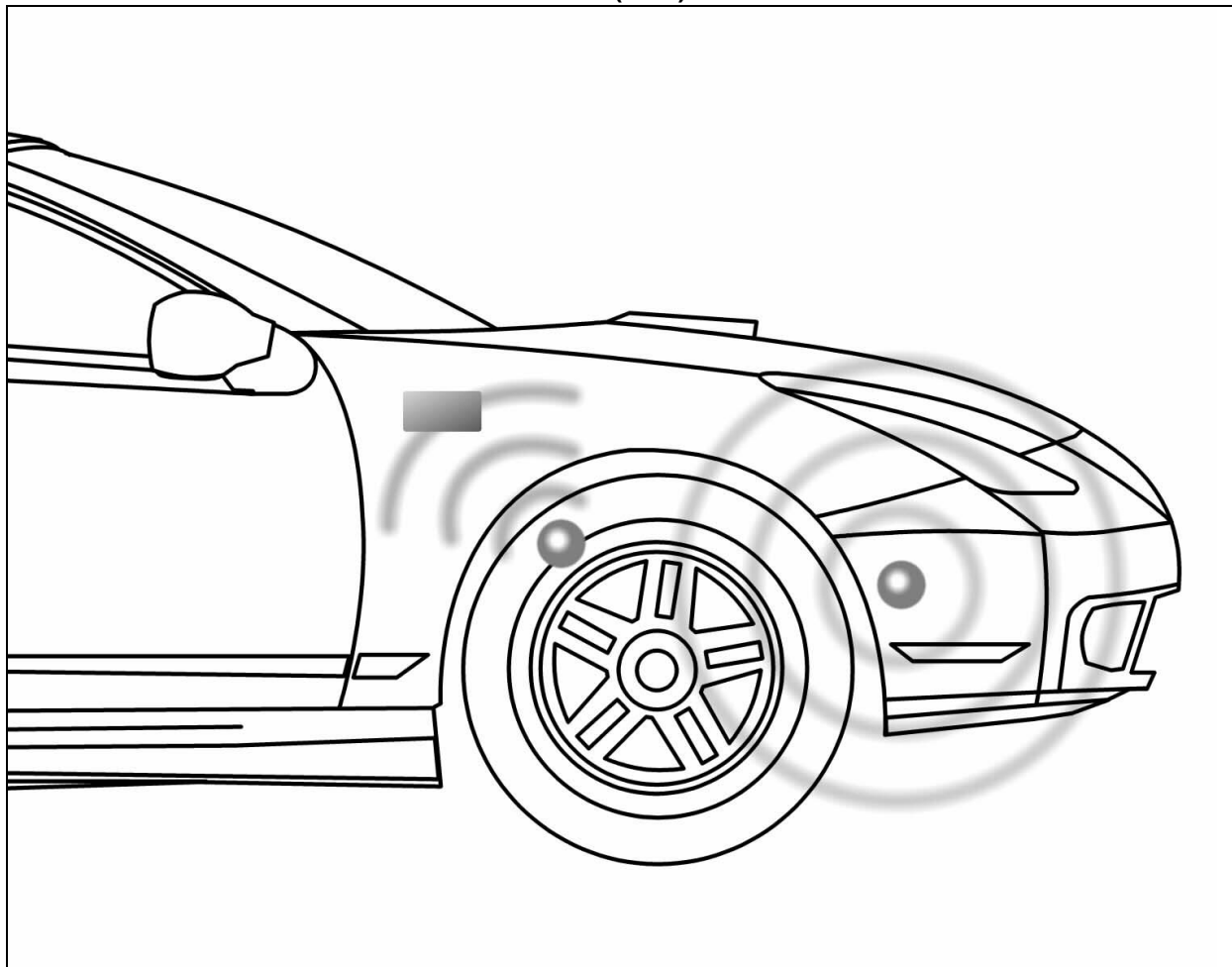

## Sensor/Transmitter (S/TX) Device

There are typically five S/TX units per vehicle, one per wheel, and the spare tire. Each unit has a unique serial number enabling the system to distinguish between each tire. When mounted within a vehicle tire, the S/TX periodically measures internal tire pressure, temperature and battery condition. It then sends a RF signal composed of the measured information to a central receiver. The device described in this document is based on Microchip's rPIC12F675 and the pressure and temperature sensing is performed by the Sensoror SP-13, a sensor IC ([www.sensoror.com](http://www.sensoror.com)). The unit is also equipped with a LF receiver unit, used to communicate to the S/TX device and to enable it from a Sleep state.

## RF Receiver Module

A central RF receiver module receives transmissions from the individual S/TX devices. The receiver can also be used as a remote keyless entry receiver, saving on overall system cost. The design of the RF receiver module falls beyond the intent of this document. A functional RF receiver module is assumed.

## LF Commander Device

The LF commander is designed to send specific commands to the S/TX unit via a 125 kHz ASK modulated signal. The LF link communicates over a short distance (1 meter or less), thus making it capable of communicating with the wheel in its immediate range. LF magnetic communications is well suited for sending commands to the S/TX devices. These commands, when received by the S/TX device, instruct it to carry out specific tasks.

## Control Unit

The control unit is responsible for initiating communications, interpreting received data and reporting the relevant information back to the vehicle. The unit will only be treated from a system overview perspective.

## Pressure Vessel

The pressure vessels (tires) are the measurement subjects, with pressure and temperature values measured and reported.

## TPM Sensor/Transmitter

### TECHNICAL SPECIFICATIONS

- Modulation Format: ASK
- Operating Voltage: 2.5-3.6V
- Low Voltage Alert Threshold: 2.5V
- Quiescent Current: TBD

### RF Specific:

- Transmit Frequency: 315 MHz
- Transmit Interval: 60, 15 or 5 seconds (LF selectable)
- Power Output: +9 dBm into 50  $\Omega$  load
- Operating Current – Transmit: 12.5 mA at max RF power

### LF Specific:

- Input Frequency: 125 kHz
- Input Sensitivity: TBD

### Pressure Sensor Specific:

- Pressure Sensor Range: 50-637 kPa absolute
- Temperature Sensor Range: -40–125°C

The schematic for the TPM S/TX is shown in **Appendix A: "Schematics"**.

## THEORY OF OPERATION

The S/TX device comprises two integrated circuits:

- Microchip's rPIC12F675 MCU/RF transmitter IC
- Sensoror SP-13 (pressure, temperature and low-voltage sensor IC)

In addition, the S/TX also includes LF input circuitry. This circuitry allows the S/TX device to receive special commands via the LF link. Refer to **Appendix A: "Schematics"** for additional circuit detail.

## rfPIC12F675 Transmitter IC

The rPIC™, based on the PIC12F675, was chosen as the heart of the S/TX for several reasons. First, the PIC12FXXX series of microcontrollers are widely used for transmitter applications and millions of PICmicro® microcontroller devices are currently used in transmitter applications today. Second, this device features an internal RC oscillator, thereby reducing the external component count which, directly reduces module cost as well as circuit board size. Third, this device includes the RF transmitter circuitry, which again reduces external component count, cost and overall size of the circuit board. The rPIC12F675 also has an internal comparator which plays an important role in decoding the information from the LF link. The internal comparator helps reduce overall part count, thereby further reducing module cost and circuit board size. Lastly, the rPIC12F675 features a 10-bit Analog-to-Digital converter, allowing the designer to use analog output pressure sensors.

The rPIC performs three functions. It monitors the data line from the SP-13 sensor IC and from the LF input, and assembles and transmits a RF message at periodic intervals.

After application of power, the rfPIC executes an initialization procedure and goes into a Sleep mode until a state change is detected on either the SP-13 data line or the LF input. Either of these inputs generates a wake-up, causing the rfPIC to transition into the Run mode. If the wake-up was generated by the SP-13, the rfPIC reads the incoming data, assembles the data into an appropriate message, and transmits the message via the RF transmitter. Once the RF message is sent, the rfPIC reenters the Sleep mode. If the wake-up was generated by the LF input, the rfPIC interprets the LF message, executes the command and then reenters the Sleep mode.

### RF Circuitry

The PLL style transmitter within the rfPIC requires minimum external components to complete the RF transmitter. The fundamental frequency of the transmitter is determined by Y1. To derive the appropriate crystal frequency, simply divide the desired transmit frequency by 32. For example, if the desired transmit frequency is 315 MHz, the crystal frequency is 9.84375 MHz.

Loop antenna L3 is matched to the single-ended RF driver via C3 and C8, which also form the resonant tank. Refer to the "Matching Small Loop Antennas to rfPIC™ Devices" Application Note AN831 (DS00831) and "Designing Loop Antennas for the rfPIC12F675" Application Note AN868 (DS00868) for additional technical detail on selecting the appropriate component values for your RF application.

Capacitor C4 is selected to provide decoupling for the 3V supply. Be sure the components selected for your application have a self-resonant frequency well above the desired transmit frequency. The filter formed by L2 and R6 further help decouple the high frequency energy from the rest of the circuitry. The R6 also de-Q's the antenna.

The output power of the transmitter circuit can be adjusted via R8, maximum power is obtained when it is left an open circuit. The transmit power can be changed per the "Power Select Resistor Select" table located in the "rfPIC12F675" Data Sheet (DS70091). This is also useful when trying to certify a product to FCC regulations.

**FIGURE 2: RF CIRCUITRY**

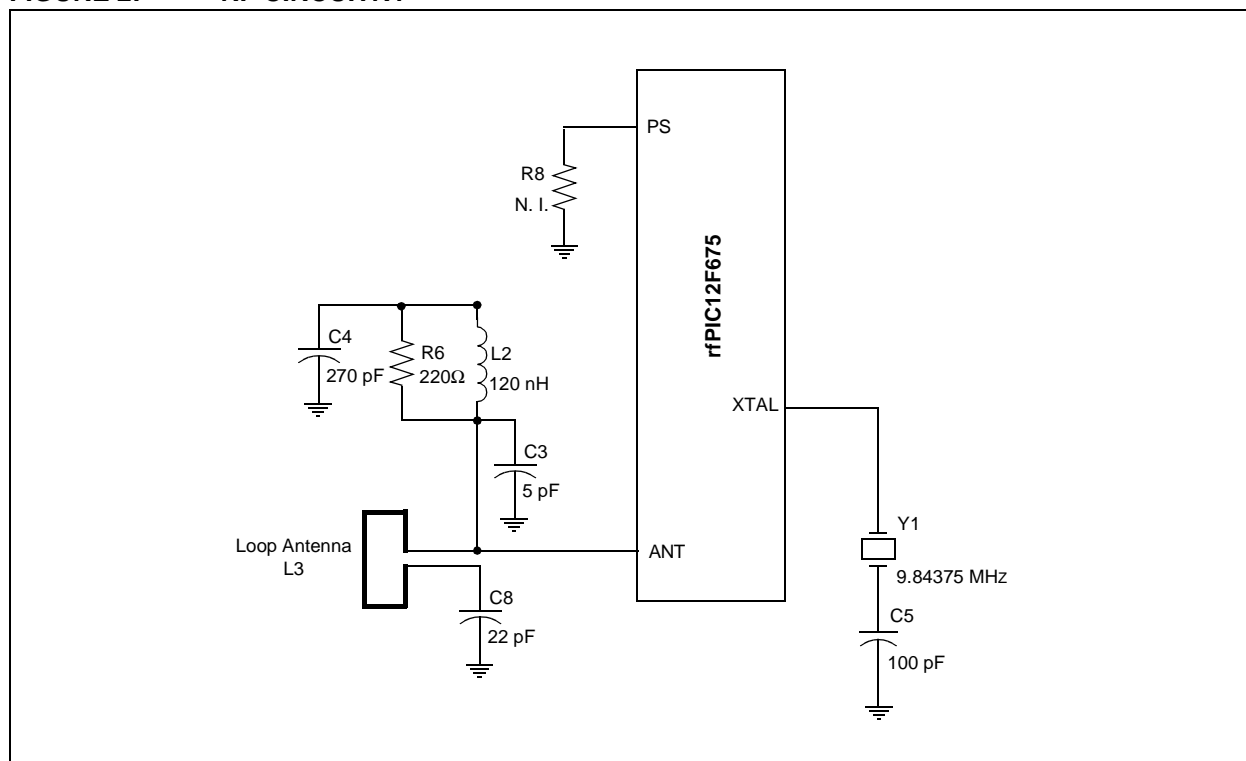

## Sensoror SP-13 Sensor IC

The SP-13 sensor IC performs several functions. It measures pressure, temperature, and generates a flag when the battery voltage drops below a predetermined threshold. The SP-13 has five unique modes:

1. **Storage mode:** If the pressure is below 1.5 bar, pressure is measured every 60 seconds but no data is sent. If the pressure increases above 1.5 bars, the component shifts into the Initial mode.
2. **Initial mode:** This mode occurs at power on or if the pressure increases above 1.5 bar from Storage mode. In this mode, pressure is measured every 0.85 seconds and data is sent every 0.85 seconds. This sequence is repeated 256 times. After the sequence is repeated 256 times, the device shifts into the Normal mode only if pressure is above 1.5 bar. If the pressure is below 1.5 bar, the device will shift into the Storage mode.
3. **Normal mode:** Pressure is measured every 3.4 seconds and data is transmitted every 60 seconds. If the measured pressure differs by more than 200 mbar from the reference taken every 60 seconds, the device enters a Pressure Alert mode.
4. **Pressure Alert mode:** It is the same measurement and transmitting pattern as the Initial mode.
5. **High Temp Alert mode:** If the temperature exceeds 120°C, the SP-13 device enters into the same measurement and transmitting pattern as the Initial mode.

The SP-13 also includes a 32-bit identification number that is programmed into the device at the time of manufacture. This unique ID, when used by the central receiver, allows differentiation between S/TXs.

Sensoror, as well as several other manufacturers, continue to offer enhanced pressure sensing devices of varying functionality. Therefore, it is recommended that a TPM developer thoroughly research the market prior to making a final pressure sensor selection.

**FIGURE 3: SENSOROR SP-13 SENSOR IC**

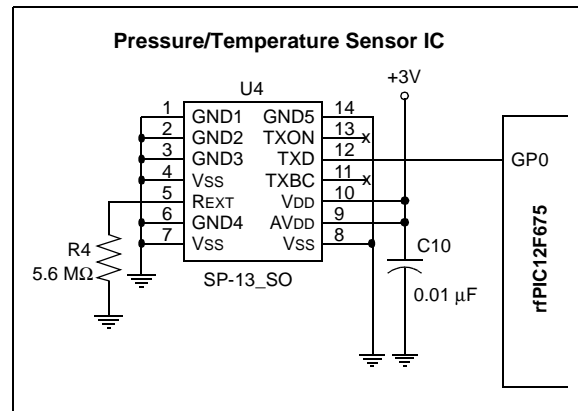

## LF Input Circuitry

The LF input is designed to receive and demodulate a 125 kHz signal and transform the received data into a specific command. The LF input circuit makes use of the internal comparator of the rPIC, thereby reducing cost, module size and quiescent current. The LF input circuitry features a LC tank circuit that is tuned to 125 kHz. The LF sensing input comprises L1 and C11. L1 is specially designed by Coilcraft for this type of application. It provides good sensitivity in a compact package. A conventional coil could be used in its place, but overall circuit sensitivity or range would be reduced. Schottky diode D3 is used to clamp the voltage developed across the LC tank to safe levels. The output of the LC tank circuit, after passing through current limiting resistor R5, is fed into the rPIC comparator's negative input. The comparator's positive input is configured as VREF through the rPIC12F675's VREF module. The output of the comparator is then fed into an envelope detector consisting of Schottky diode D2, capacitor C9 and resistor R3. C9 and R3 are selected to provide adequate filtering of the LF frequency without rounding the edges of the desired data signal. The output of the envelope detector is then fed directly into a port pin on the rPIC and used to process the LF data.

Without a limiting diode, the LF input circuit may be prone to being overdriven when strong LF fields are present. This can be seen when the LF commander device is in close proximity to the S/TX device. The envelope detection circuit can be abandoned to reduce cost, but doing so would require additional data extraction software.

**FIGURE 4: LF CIRCUITRY**

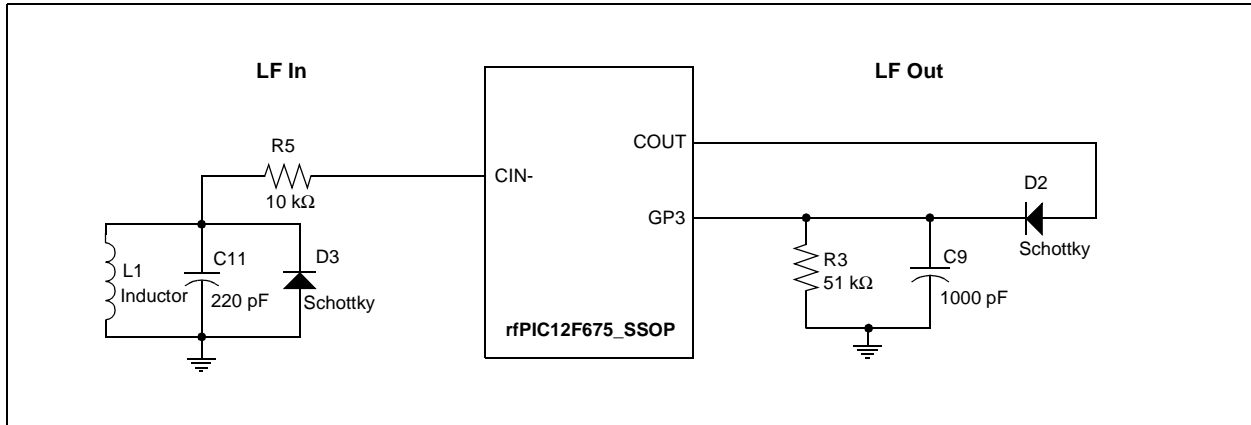

Details of the LF transmission format and the specific commands can be found in the Section, "LF Commander".

### RF Transmission Format

The encoding method used for this demonstration system is the 1/3-2/3 PWM format with  $T_E$  (basic pulse element) time of 400  $\mu$ s and a bit period of  $3 \times T_E$  or 1.2 ms.

**FIGURE 5: RF TRANSMISSION ENCODING METHOD**

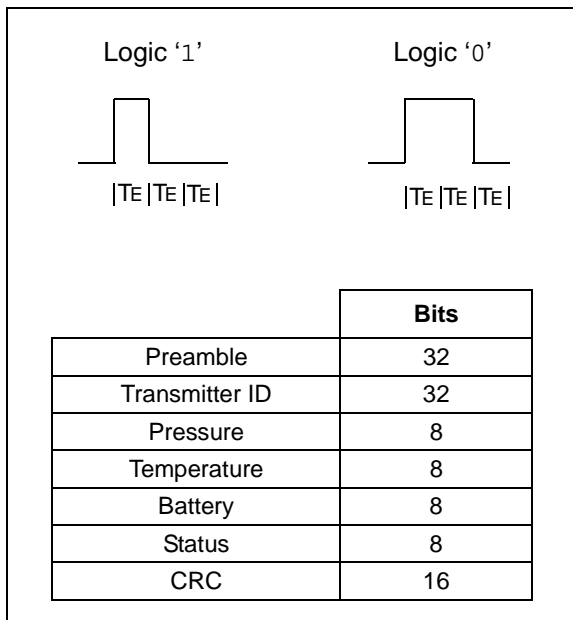

**Preamble:** The preamble is a series of 31 logic '1' bits followed by a single logic '0' bit. The preamble allows the receiver to recognize the RF transmission as a valid S/TX message. The preamble also allows the receiver to synchronize to the RF message, thereby compensating for any oscillator inaccuracies within the transmitter. The system designer may vary the number of preamble bits based on system requirements. Longer preamble bit lengths may be appropriate where receiver quiescent current is an issue. Shorter preamble bit lengths may be appropriate where S/TX battery usage is a concern. In either case, it is purely a trade-off between receiver quiescent current and battery power consumed by the S/TX device.

**Transmitter ID:** The 32 transmitter ID bits are used to uniquely identify each S/TX. A frame of 32 bits insures that there is a very low probability that any two S/TXs will have the same ID.

**Pressure:** The pressure in kPa is obtained by multiplying the unsigned binary value of this byte by 2.5.

**Temperature:** The temperature in degrees C is obtained by subtracting 40 from the unsigned value of byte 8.

**Battery:** Bit 7 of this byte indicates the battery condition. A logic '1' is considered normal while a logic '0' indicates a low battery voltage.

**Status:** This status byte contains the following information:

**Bits 0 and 1:** Indicate operating state of sensor IC

00 = Initial or Storage mode

01 = Normal mode

10 = Pressure Alert mode

11 = Temperature Alert mode

**CRC (2 bytes):** Implement according to CCITT standards.

## LF Commander

### THEORY OF OPERATION

The system proposed in this document is based on an auto-location system, enabling it to detect the position of a specific S/TX device. This requires a LF commander device at each wheel arc and possibly at the spare tire mounting position.

Having a handheld LF commander unit can enable a lower cost system. Although, this would require that the system be manually relearned after a tire rotation, the S/TX device is able to detect tire rotation or some other system to engage data transmission. The LF commander device is capable of sending commands to the S/TX device via a LF transmission such as:

- Enable RF transmissions
- Disable RF transmissions
- Transmit an immediate message
- Transmit at 60-second intervals
- Transmit at 15-second intervals
- Transmit at 5-second intervals

The LF commander unit is based on the PIC16F628 MCU device. Communication between the LF commander and the S/TX is accomplished via magnetic field. When the LF commander is transmitting a message, it is essentially creating a magnetic field by exciting a series LC circuit. The LC circuit is excited by the PICmicro's PWM port. This port is set up to generate a 50% duty cycle at 125 kHz. The command data is then modulated on this 125 kHz signal in the form of ASK modulation. Functionally, this is accomplished by instructing the PICmicro to toggle the PWM port between 0% and 50% duty cycle at the rate of the data.

### LF TRANSMISSION FORMAT

The encoding format used in the LF link is a 1/3 - 2/3 PWM format with  $400 \mu\text{s}$   $T_E$  (basic pulse element). Selecting  $400 \mu\text{s}$   $T_E$  or greater insures the magnetic field generated by the series LC circuit has adequate time to rise and decay, without requiring too much wave shaping of the recovered square wave in the S/TX circuitry.

The transmission data format for the LF link is shown in Figure 6.

**FIGURE 6: LF TRANSMISSION ENCODING METHOD**

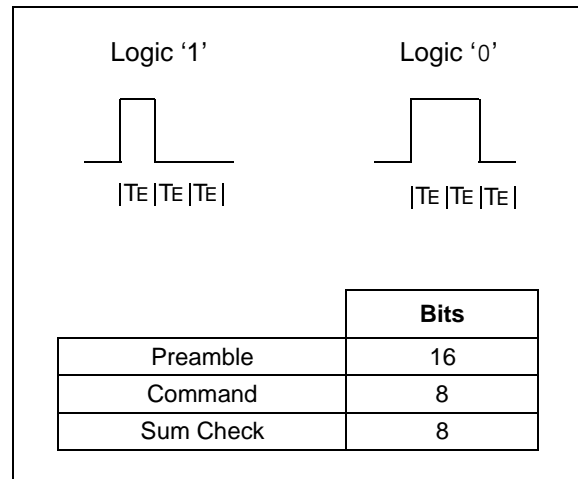

**Preamble:** The preamble is a series of 15 logic '1' bits and 1 logic '0' bit. This reduces the chance of the S/TX receiving erroneous data from electronic devices that generate strong 125 kHz fields. Computer CRT's and switching power supplies are examples of such devices.

**Command:** These 8 bits of data contains the specific command that the S/TX is being asked to perform. Table 1 illustrates the various commands (MSB is left most column).

**TABLE 1: BIT FUNCTIONS**

Bits	Function
01101101	Enable RF transmissions
10010010	Disable RF transmissions
10101010	Transmit an immediate RF message
10110110	Transmit at 60-second interval
11001100	Transmit at 15-second interval
11010011	Transmit at 5-second interval

**Sum Check:** Calculated by adding contents of the command byte with '10101010'.

## SUMMARY

TPM use in the automotive industry is growing, driven by customer demand, improved safety, and possible compulsory-usage legislation. Microchip's low-cost rfPIC devices are well suited for the application and help reduce the overall TPM system cost.

The use of rfPIC based S/TX makes for a flexible solution that allows for the merging with existing systems such as security, PKE, RKE and more.

FIGURE 7: PHOTOGRAPH OF SENSOR/TRANSMITTER DEVICE

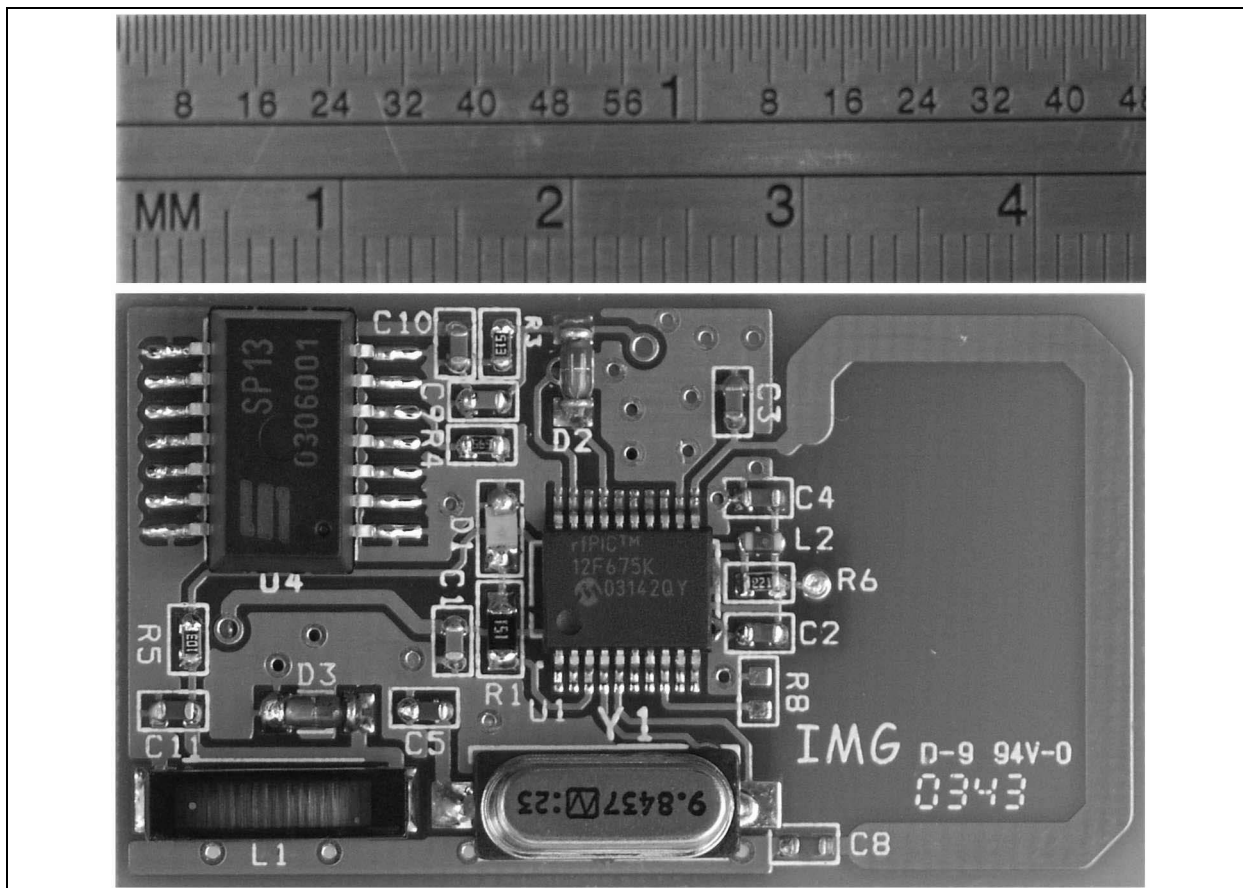

## REFERENCE DOCUMENTS

The following reference documents are available from Microchip's web site at [www.microchip.com](http://www.microchip.com).

1. "Low Frequency Magnetic Transmitter Design" Application Note (AN232), DS00232; Microchip Technology Inc.
2. "Designing Loop Antennas for the rfPIC12F675" Application Note (AN868), DS00868; Microchip Technology Inc.
3. "Matching Small Loop Antennas to rfPIC Devices" Application Note (AN831), DS00831; Microchip Technology Inc.
4. "Magnetic Tuning of Resonant Resistors and Methods for Increasing Sensitivity" Application Note (AN832), DS00832; Microchip Technology Inc.
5. "Optimizing PLL Filters for the rfPIC12C509A and rfHCS362" Application Note (AN846), DS00846; Microchip Technology Inc.
6. "rfPIC12F675" Data Sheet, DS70091; Microchip Technology Inc.

**Note:** Microchip has a confidential Application Note on Magnetic Sensors, "Magnetic Tuning of Resonant Resistors and Methods for Increasing Sensitivity" Application Note, DS00832. Contact Microchip for a Non-Disclosure Agreement in order to obtain this application note.



APPENDIX A: SCHEMATICS

FIGURE A-1: TPM SENSOR/TRANSMITTER SCHEMATIC

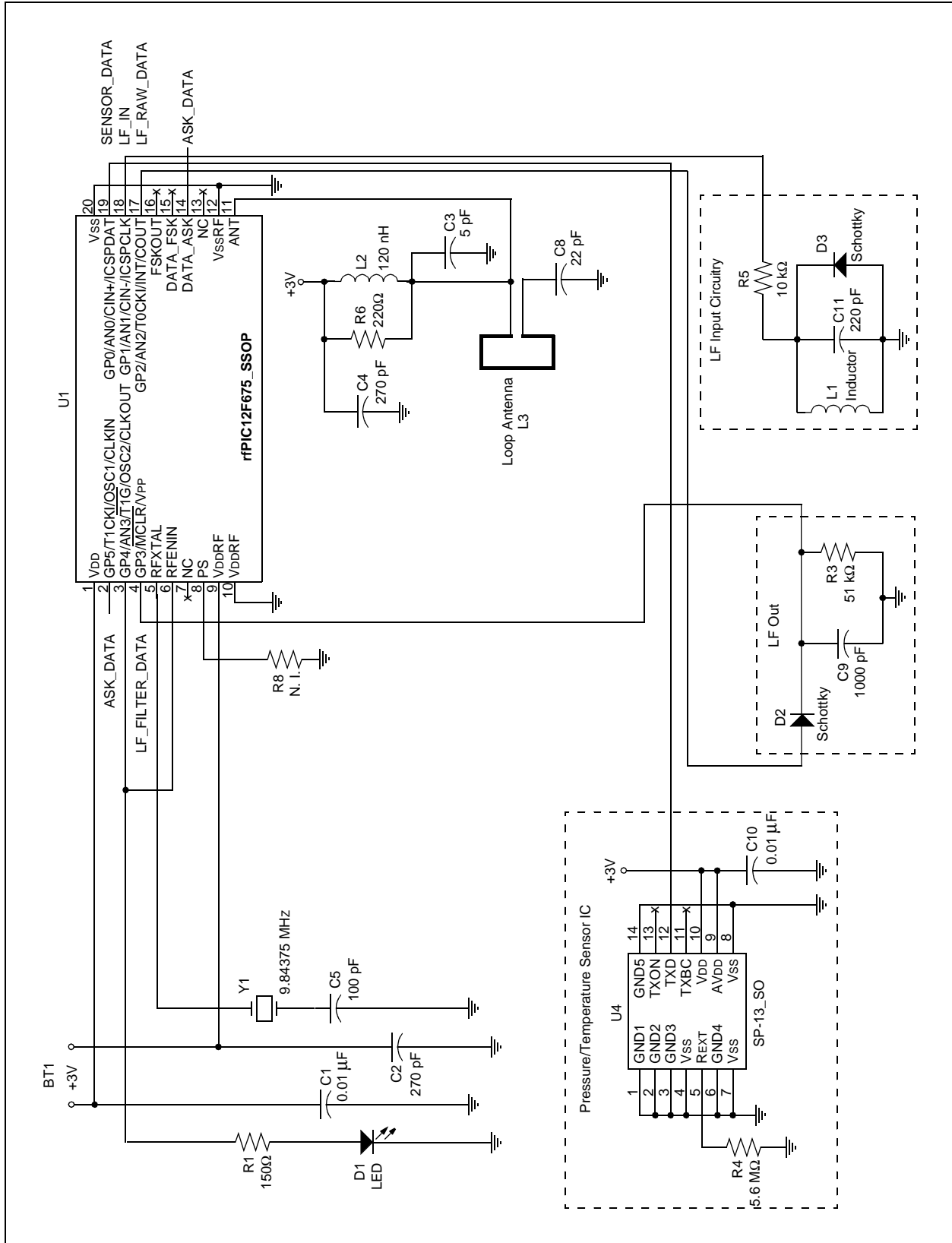

# AN238

---

NOTES:

---

---

**Note the following details of the code protection feature on Microchip devices:**

- Microchip products meet the specification contained in their particular Microchip Data Sheet.
- Microchip believes that its family of products is one of the most secure families of its kind on the market today, when used in the intended manner and under normal conditions.
- There are dishonest and possibly illegal methods used to breach the code protection feature. All of these methods, to our knowledge, require using the Microchip products in a manner outside the operating specifications contained in Microchip's Data Sheets. Most likely, the person doing so is engaged in theft of intellectual property.
- Microchip is willing to work with the customer who is concerned about the integrity of their code.
- Neither Microchip nor any other semiconductor manufacturer can guarantee the security of their code. Code protection does not mean that we are guaranteeing the product as "unbreakable."

Code protection is constantly evolving. We at Microchip are committed to continuously improving the code protection features of our products. Attempts to break Microchip's code protection feature may be a violation of the Digital Millennium Copyright Act. If such acts allow unauthorized access to your software or other copyrighted work, you may have a right to sue for relief under that Act.

---

Information contained in this publication regarding device applications and the like is intended through suggestion only and may be superseded by updates. It is your responsibility to ensure that your application meets with your specifications. No representation or warranty is given and no liability is assumed by Microchip Technology Incorporated with respect to the accuracy or use of such information, or infringement of patents or other intellectual property rights arising from such use or otherwise. Use of Microchip's products as critical components in life support systems is not authorized except with express written approval by Microchip. No licenses are conveyed, implicitly or otherwise, under any intellectual property rights.

**Trademarks**

The Microchip name and logo, the Microchip logo, Accuron, dsPIC, KEELOQ, MPLAB, PIC, PICmicro, PICSTART, PRO MATE and PowerSmart are registered trademarks of Microchip Technology Incorporated in the U.S.A. and other countries.

AmpLab, FilterLab, microID, MXDEV, MXLAB, PICMASTER, SEEVAL, SmartShunt and The Embedded Control Solutions Company are registered trademarks of Microchip Technology Incorporated in the U.S.A.

Application Maestro, dsPICDEM, dsPICDEM.net, dsPICworks, ECAN, ECONOMONITOR, FanSense, FlexROM, fuzzyLAB, In-Circuit Serial Programming, ICSP, ICEPIC, Migratable Memory, MPASM, MPLIB, MPLINK, MPSIM, PICKit, PICDEM, PICDEM.net, PICtail, PowerCal, PowerInfo, PowerMate, PowerTool, rFLAB, rPIC, Select Mode, SmartSensor, SmartTel and Total Endurance are trademarks of Microchip Technology Incorporated in the U.S.A. and other countries.

Serialized Quick Turn Programming (SQTP) is a service mark of Microchip Technology Incorporated in the U.S.A.

All other trademarks mentioned herein are property of their respective companies.

© 2004, Microchip Technology Incorporated, Printed in the U.S.A., All Rights Reserved.

 Printed on recycled paper.

**QUALITY MANAGEMENT SYSTEM  
CERTIFIED BY DNV  
== ISO/TS 16949:2002 ==**

*Microchip received ISO/TS-16949:2002 quality system certification for its worldwide headquarters, design and wafer fabrication facilities in Chandler and Tempe, Arizona and Mountain View, California in October 2003. The Company's quality system processes and procedures are for its PICmicro® 8-bit MCUs, KEELOQ® code hopping devices, Serial EEPROMs, microperipherals, nonvolatile memory and analog products. In addition, Microchip's quality system for the design and manufacture of development systems is ISO 9001:2000 certified.*



## WORLDWIDE SALES AND SERVICE

### AMERICAS

#### Corporate Office

2355 West Chandler Blvd.  
Chandler, AZ 85224-6199  
Tel: 480-792-7200  
Fax: 480-792-7277  
Technical Support: 480-792-7627  
Web Address: <http://www.microchip.com>

#### Atlanta

3780 Mansell Road, Suite 130  
Alpharetta, GA 30022  
Tel: 770-640-0034  
Fax: 770-640-0307

#### Boston

2 Lan Drive, Suite 120  
Westford, MA 01886  
Tel: 978-692-3848  
Fax: 978-692-3821

#### Chicago

333 Pierce Road, Suite 180  
Itasca, IL 60143  
Tel: 630-285-0071  
Fax: 630-285-0075

#### Dallas

4570 Westgrove Drive, Suite 160  
Addison, TX 75001  
Tel: 972-818-7423  
Fax: 972-818-2924

#### Detroit

Tri-Atria Office Building  
32255 Northwestern Highway, Suite 190  
Farmington Hills, MI 48334  
Tel: 248-538-2250  
Fax: 248-538-2260

#### Kokomo

2767 S. Albright Road  
Kokomo, IN 46902  
Tel: 765-864-8360  
Fax: 765-864-8387

#### Los Angeles

18201 Von Karman, Suite 1090  
Irvine, CA 92612  
Tel: 949-263-1888  
Fax: 949-263-1338

#### San Jose

1300 Terra Bella Avenue  
Mountain View, CA 94043  
Tel: 650-215-1444  
Fax: 650-961-0286

#### Toronto

6285 Northam Drive, Suite 108  
Mississauga, Ontario L4V 1X5, Canada  
Tel: 905-673-0699  
Fax: 905-673-6509

### ASIA/PACIFIC

#### Australia

Suite 22, 41 Rawson Street  
Epping 2121, NSW  
Australia  
Tel: 61-2-9868-6733  
Fax: 61-2-9868-6755

#### China - Beijing

Unit 706B  
Wan Tai Bei Hai Bldg.  
No. 6 Chaoyangmen Bei Str.  
Beijing, 100027, China  
Tel: 86-10-85282100  
Fax: 86-10-85282104

#### China - Chengdu

Rm. 2401-2402, 24th Floor,  
Ming Xing Financial Tower  
No. 88 TIDU Street  
Chengdu 610016, China  
Tel: 86-28-86766200  
Fax: 86-28-86766599

#### China - Fuzhou

Unit 28F, World Trade Plaza  
No. 71 Wusi Road  
Fuzhou 350001, China  
Tel: 86-591-7503506  
Fax: 86-591-7503521

#### China - Hong Kong SAR

Unit 901-6, Tower 2, Metroplaza  
223 Hing Fong Road  
Kwai Fong, N.T., Hong Kong  
Tel: 852-2401-1200  
Fax: 852-2401-3431

#### China - Shanghai

Room 701, Bldg. B  
Far East International Plaza  
No. 317 Xian Xia Road  
Shanghai, 200051  
Tel: 86-21-6275-5700  
Fax: 86-21-6275-5060

#### China - Shenzhen

Rm. 1812, 18/F, Building A, United Plaza  
No. 5022 Binhe Road, Futian District  
Shenzhen 518033, China  
Tel: 86-755-82901380  
Fax: 86-755-82951393

#### China - Shunde

Room 401, Hongjian Building, No. 2  
Fengxiangnan Road, Ronggui Town, Shunde  
District, Foshan City, Guangdong 528303, China  
Tel: 86-757-28395507 Fax: 86-757-28395571

#### China - Qingdao

Rm. B505A, Fullhope Plaza,  
No. 12 Hong Kong Central Rd.  
Qingdao 266071, China  
Tel: 86-532-5027355 Fax: 86-532-5027205

#### India

Divyasree Chambers  
1 Floor, Wing A (A3/A4)  
No. 11, O'Shaughnessy Road  
Bangalore, 560 025, India  
Tel: 91-80-2290061 Fax: 91-80-2290062

#### Japan

Benex S-1 6F  
3-18-20, Shinyokohama  
Kohoku-Ku, Yokohama-shi  
Kanagawa, 222-0033, Japan  
Tel: 81-45-471-6166 Fax: 81-45-471-6122

#### Korea

168-1, Youngbo Bldg. 3 Floor  
Samsung-Dong, Kangnam-Ku  
Seoul, Korea 135-882  
Tel: 82-2-554-7200 Fax: 82-2-558-5932 or  
82-2-558-5934

#### Singapore

200 Middle Road  
#07-02 Prime Centre  
Singapore, 188980  
Tel: 65-6334-8870 Fax: 65-6334-8850

#### Taiwan

Kaohsiung Branch  
30F - 1 No. 8  
Min Chuan 2nd Road  
Kaohsiung 806, Taiwan  
Tel: 886-7-536-4818  
Fax: 886-7-536-4803

#### Taiwan

Taiwan Branch  
11F-3, No. 207  
Tung Hua North Road  
Taipei, 105, Taiwan  
Tel: 886-2-2717-7175 Fax: 886-2-2545-0139

### EUROPE

#### Austria

Durisolstrasse 2  
A-4600 Wels  
Austria  
Tel: 43-7242-2244-399  
Fax: 43-7242-2244-393

#### Denmark

Regus Business Centre  
Lautrup høj 1-3  
Ballerup DK-2750 Denmark  
Tel: 45-4420-9895 Fax: 45-4420-9910

#### France

Parc d'Activite du Moulin de Massy  
43 Rue du Saule Trapu  
Batiment A - 1er Etage  
91300 Massy, France  
Tel: 33-1-69-53-63-20  
Fax: 33-1-69-30-90-79

#### Germany

Steinheilstrasse 10  
D-85737 Ismaning, Germany  
Tel: 49-89-627-144-0  
Fax: 49-89-627-144-44

#### Italy

Via Quasimodo, 12  
20025 Legnano (MI)  
Milan, Italy  
Tel: 39-0331-742611  
Fax: 39-0331-466781

#### Netherlands

P. A. De Biesbosch 14  
NL-5152 SC Drunen, Netherlands  
Tel: 31-416-690399  
Fax: 31-416-690340

#### United Kingdom

505 Eskdale Road  
Wokingham  
Wokingham  
Berkshire, England RG41 5TU  
Tel: 44-118-921-5869  
Fax: 44-118-921-5820

01/26/04