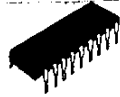

SANYO

No.952C

**LB1410**

Monolithic Digital IC

LEVEL METER

Use

- . AC level meters such as VU meters.
- . DC level meters such as signal meters.

Functions

1. Display format
Ten red or green LEDs display the input level in the shape of a bar.
2. Input amplifier
Wide application is available owing to the built-in DC amplifier whose gain is variable with external resistors.
3. Comparator level
Setting is made by steps of 3dB as follows.
-21dB, -18dB, -15dB, -12dB, -9dB, -6dB, -3dB, 0dB, +3dB, +6dB.
4. Supply voltage
Wide recommended supply voltage range : 5.5V to 16 V (If pin Vref2 is used, 7V to 16V).
5. Reference voltage
Constant voltage output is available with an external transistor owing to pin Vref2=5V.

Comparator Level/OUT pin voltage at $T_a=25^\circ\text{C}$, $V_{CC}=12\text{V}$, $V_{ref1}=3\text{V}$

Comparator level	Pin No.	min	typ	max	unit
D1	7	0.06	0.13*	0.17	V
D2	8	0.11	0.18*	0.25	V
D3	9	0.20	0.27*	0.34	V
D4	10	0.30	0.38*	0.46	V
D5	11	0.45	0.53*	0.61	V
D6	12	0.66	0.75	0.84	V
D7	13	0.97	1.06	1.15	V
D8	14	1.40	1.50	1.60	V
D9	16	2.02	2.12	2.22	V
D10	17	2.90	3.00	3.10	V

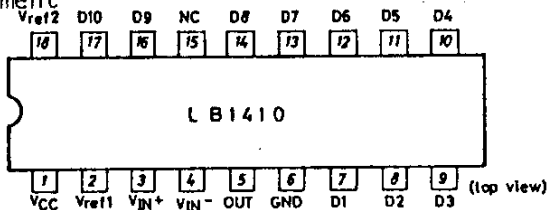
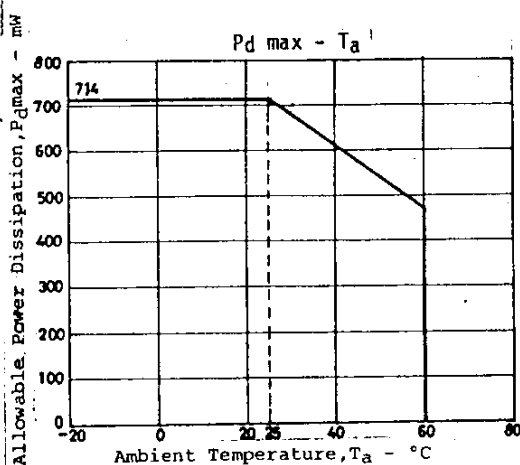
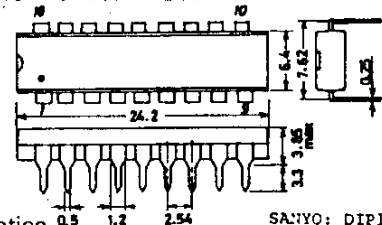
* : No overlap occurs in each individual IC.
Pin AssignmentCase Outline 3007A-D18IC
(unit:mm)

Specifications and information herein are subject to change without notice.

SANYO: DIP18

SANYO Electric Co., Ltd. Semiconductor Overseas Marketing Div.
15-13, 6 chome, Sotokanda, Chiyoda-ku, TOKYO 101 JAPAN

8277KI/8225MW/9124KI/3052KI, TS No.952-1/3

Equivalent Circuit

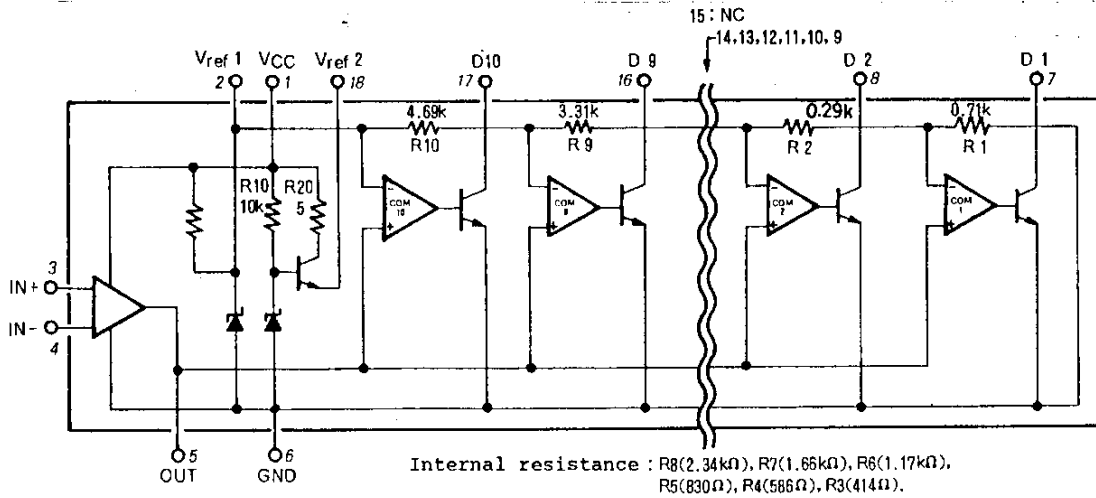

Absolute Maximum Ratings at $T_a=25^\circ\text{C}$

				unit
Maximum Supply Voltage	V_{CCmax}	Pin 1	-0.3 to +18	V
Input Voltage	V_{IN}	Pin 3, 4	-0.3 to V_{CC}	V
D1 to D10 Output Voltage	$V_{OUT(D)}$	D1 to D10 OFF	-0.3 to +18	V
D1 to D10 Output Current	$I_{OL(D)}$	Pins 7 to 17, D1 to D10 ON (Pin 15 NC)	+30	mA
First Reference Flow-out Current	$I_{ref(1)}$	Pin 2	-1 to 0	mA
Second Reference Flow-out Current	$I_{ref(2)}$	Pin 18	-6 to 0	mA
V_{OUT} Supply Voltage	V_{OUT}	Pin 5	-0.3 to 6	V
Allowable Power Dissipation	P_{dmax}	$T_a=55^\circ\text{C}$	500	mW
Operating Temperature	T_{opg}		-10 to +60	$^\circ\text{C}$
Storage Temperature	T_{stg}		-40 to +125	$^\circ\text{C}$

Allowable Operating Conditions at $T_a=25^\circ\text{C}$

				unit
Supply Voltage	V_{CC}	Pin 1, (): Using V_{ref2}	-5.5 to +16 (+7 to +16)	V
Input Voltage	$V_{IN+orVIN-}$	Pin 3 or 4	-0.3 to V_{CC}	V
Output Pin Load Resistance	R_L	Between pin 5 OUT and pin 6 GND.	15k to 20k	ohm

Electrical Characteristics at $T_a=25^\circ\text{C}, V_{CC}=12\text{V}$

			min	typ	max	unit
Input Bias Current (Amplifier)	$I_{IN+(A)}$	Pin3, $V_{IN+}=0\text{V}, V_{IN-}=3\text{V}, \text{GND}=0\text{V}$	-2		0	μA
	$I_{IN-(A)}$	Pin4, $V_{IN+}=3\text{V}, V_{IN-}=0\text{V}, \text{GND}=0\text{V}$	-2		0	μA
Input Bias Current (Comparator) + Output Leak Current	$I_{IN+(C)+}$	Pin5, $V_{IN+}=0\text{V}, V_{IN-}=3\text{V}, \text{OUT}=0\text{V}, \text{GND}=0\text{V}$	-10		0	μA
	$I_{OL(A)}$					
Offset Voltage	$V_{offset(1)}$	Pin5, $V_{CC}=6\text{V}, V_{IN+}=V_{IN-}=0\text{V}, \text{GND}=-6\text{V}, \text{GAIN}=20\text{dB}$	-180		+180	mV
	$V_{offset(2)}$	Pin5, $V_{IN+}=V_{IN-}=0\text{V}, \text{GND}=0\text{V}, \text{GAIN}=20\text{dB}$	0		+180	mV
First Reference Voltage	$V_{ref(1)}$	Pin2, $I_{ref}=0$ to 1mA	2.6		3.0	V
Second Reference Voltage	$V_{ref(2)}$	Pin18, $I_{ref}=5\text{mA}$	4.2	4.7	5.2	V
Current Dissipation	I_{CC}	Pin1, $V_{IN+}=3\text{V}, V_{IN-}=0\text{V}$		10	20	mA
Amplifier Gain	VC	Open loop	30			dB

Continued on next page.

Continued from preceding page.

			min	typ	max	unit
Output Flow-out Current	I_{OH}	Pin5, $V_{IN+}=3V, V_{IN-}=0V,$ $V_{OUT}=0V$			-10	mA
Pin D Output ON Voltage	$V_{OL(D)}$	Pin7 to 17, D1 to D10, $I_{OL}=$ $20mA, V_{IN+}=3V, V_{IN-}=0V$ (Pin 15 NC)			1.2	V
Pin D Output Leak Current	$I_{OH(D)}$	Pin7 to 17, D1 to D10, $V_{IN+}=0V, V_{IN-}=3V, V_{D1}$ to $D10=12V$ (Pin: 15 NC)			10	μA
Output Voltage (Amplifier) V_{OH}		Pin5, $V_{CC}=5.5V, V_{IN+}=3V,$ $V_{IN-}=0V, R_L=15kohms$	4			V
		Pin5, $V_{CC}=12V, V_{IN+}=3V,$ $V_{IN-}=0V, R_L=15kohms$	9.5			V

Application Circuits (with offset adjustment)

. Circuit not using V_{ref2}

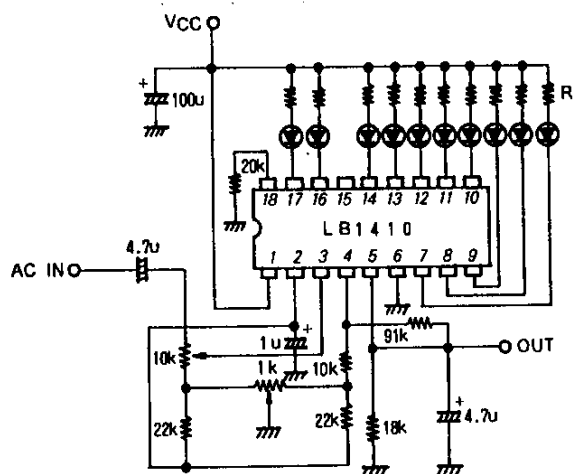

Adjusting procedure

1. Turn the center of 10kohm VR largely to 4.7uF capacitor side.
2. Input AC signal of 50/ 20mV from AC IN.
3. Adjust 1kohm VR so that the output at OUT becomes 500mV DC.

- . Equation used in the calculation of R to be inserted in series with LED.

Gain : 20dB

$$R(\text{red}) = (V_{CC}-2.5)/6 \text{ kohms}$$

$$R(\text{green}) = (V_{CC}-2.8)/18 \text{ kohms}$$

. Circuit using V_{ref2}

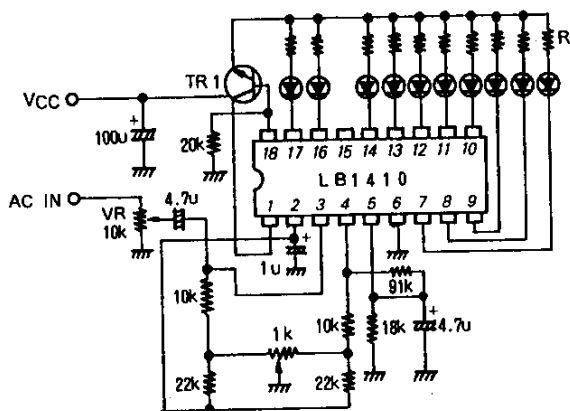

Adjusting procedure

- . R to be inserted in series with LED is as follows irrespective of V_{CC} .
 $R(\text{red}) = 360ohms$ (App. 6mA)
 $R(\text{green}) = 100ohms$ (App. 18mA)
- . TR1 should be chosen with P_C considered. The following transistors are recommended.
 Red LED drive 2SD400
 Green LED drive 2SD325

Information furnished by SANYO is believed to be accurate and reliable. However, no responsibility is assumed by SANYO for its use; nor for any infringements of patents or other rights of third parties which may result from its use, and no license is granted by implication or otherwise under any patent or patent rights of SANYO.