

AN6150

Speech Network Circuit

■ Overview

The AN6150 is an integrated circuit designed for telephone speech network. It has the basic function necessary to apply a sound signal onto the line and is applicable for various types of handsets.

■ Features

- Wide operating voltage range : 3 to 11.5V
- Built-in amplifiers for "Dial Tone" and "DTMF"
- Amplifier output switchable.
- Each amplifier gain automatically changeable depending on line current.
- Various types of microphones and receivers are available.

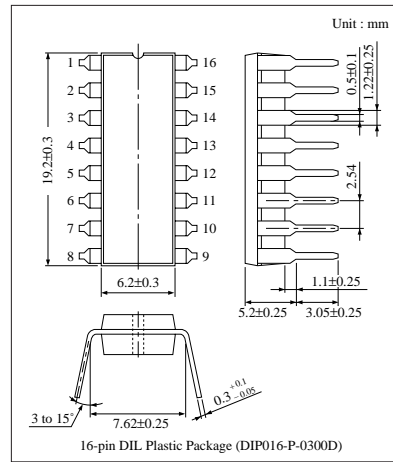

■ Block Diagram

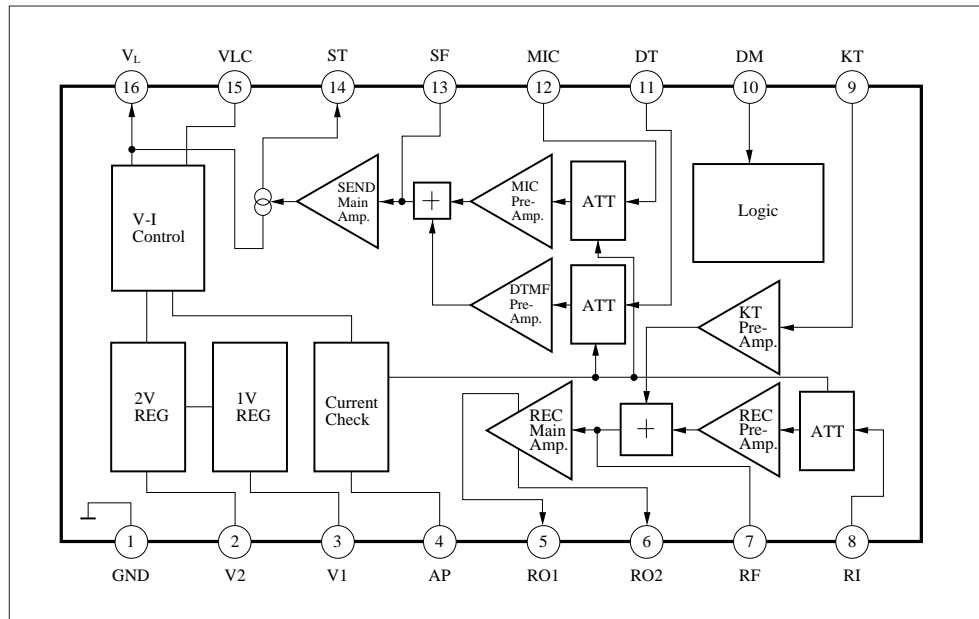

■ Pin Descriptions

Pin No.	Pin name	Pin No.	Pin name
1	GND	9	KEY In TONE input
2	2V REG.	10	Dial mute SW
3	1V REG.	11	DTMF input
4	ATT control	12	MIC input
5	REC output	13	Transmission filter
6	REC output	14	SIDE tone
7	REC filter	15	LIN filter
8	REC input	16	LIN

■ Absolute Maximum Ratings (Ta=25°C)

Parameter	Symbol	Rating	Unit
Line voltage	V_L	14.4	V
Line current	I_L	135	mA
Power dissipation (Ta=60°C)	P_D	1380	mW
Operating ambient temperature	T_{opr}	-30 to +75	°C
Storage temperature	T_{stg}	-55 to +150	°C

■ Electrical Characteristics ($I_L=40mA$, $f_{in}=1kHz$, Ta=25°C)

Parameter	Symbol	Condition	min	typ	max	Unit
Receive System						
Receiver gain *1	G_{V-R}	$V_i=-45dBm$	-7	-4.5	-2	dBm
Receiver output distortion *1	THD_{-R}	$V_i=-45dBm$	—	1	5	%
Max. receiver level *1	V_{O-R}	THD=5%	0	4	—	dBm
Receiver auto pad *1	ΔAP_{-R}	$V_i=-45dBm$, $DI_L=100$ to 20mA	-5.5	-3	-0.5	dB
KEY IN TONE gain *1	G_{V-KT}	$V_i=-40dBm$, Dial Mute SW- ON	-25	-22.5	-20	dBm
Transmission System						
Transmission gain *2	G_{V-T}	$V_i=-45dBm$	-6	-4	-2	dBm
Transmission output distortion *2	THD_{-T}	$V_i=-45dBm$	—	1	5	%
Max. transmission level *2	V_{O-T}	THD=5%	-2.2	2.8	—	dBm
Transmission auto pad *2	ΔAP_{-T}	$V_i=-45dBm$, $DI_L=100$ to 20mA	-6.5	-3.5	-1	dB
DTMF gain *2	G_{V-DT}	$V_i=-35dBm$, Dial Mute SW- ON	-8	-6	-4	dBm
DTMF output distortion *2	THD_{-DT}	$V_i=-35dBm$, Dial Mute SW- ON	—	1	5	%
DTMF auto pad *2	ΔAP_{-DT}	$V_i=-35dBm$, $DI_L=100$ to 20mA	-6	-4	-2	dB
Power Supply						
DC line voltage (1)	V_{L-1}	$I_L=12mA$	2.4	3	3.6	V
DC line voltage (2)	V_{L-2}	$I_L=127mA$	5.4	7.8	10.2	V
Internal supply voltage	V_{CC}	$I_L=12mA$	1.7	2.0	2.3	V

*1 Connect the 1kΩ load between Pins5 and 6 for measurement.

*2 Connect the 600Ω receiver impedance between Pins16 and 1 and measure it at the receiver side.

■ Electrical Characteristics (cont.) ($I_L=40\text{mA}$, $f_{in}=1\text{kHz}$, $T_a=25^\circ\text{C}$)

Parameter	Symbol	Condition	min	typ	max	Unit
Dial Mute input						
Dial mute OFF	V_{DM-H}		0.8	—	V_{CC}	V
Dial mute ON	V_{DM-L}		—	—	0.3	V
Input current (1)	I_{DM-H}	$V_{DM}=V_{CC}$	-2.0	0.1	2.0	μA
Input current (2)	I_{DM-L}	$V_{DM}=0\text{V}$	-2.0	-0.2	-0.02	μA
Receiver System						
K. T. output distortion *1, 4	THD_{-KT}	$V_i=-42\text{dBV}$, $I_L=40\text{mA}$	—	1	—	%
Mute						
K.T. mute *1, 4	M_{KT}	$V_i=-15\text{dBV}$, Dial mute SW- OFF	40	—	—	dB
MIC mute *2, 4	M_T	$V_i=-40\text{dBV}$, Dial mute SW- ON	60	—	—	dB
DTMF mute *2, 4	M_{DT}	$V_i=-28\text{dBV}$, Dial mute SW- OFF	40	—	—	dB
Power Supply						
AC impedance (1)*3, 4	Z_{AC-1}	$I_L=30\text{mA}$, $f_{in}=1\text{kHz}$	400	670	800	Ω
AC impedance (2)*3, 4	Z_{AC-2}	$I_L=90\text{mA}$, $f_{in}=1\text{kHz}$	400	620	800	Ω

*1 Connect the $1\text{k}\Omega$ load between Pins5 and 6 for measurement

*2 Connect the 600Ω receiver impedance between Pins16 and 1 measure it at the receiver side.

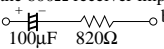
*3 Connect  between Pins16 and 1 for measurement.

*4 Characteristics above are of reference value for design but not guaranteed values.

■ Characteristics Curve

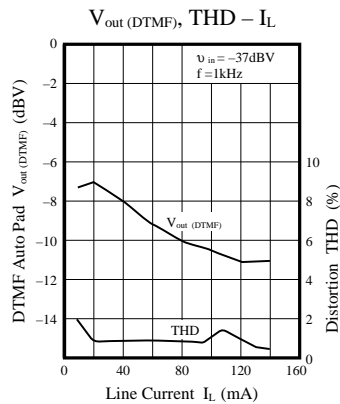
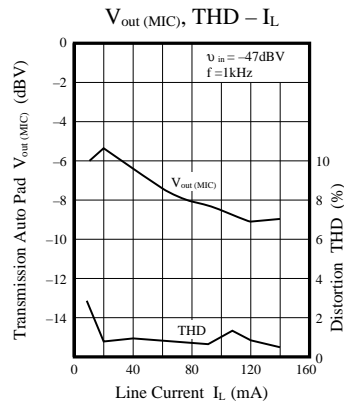
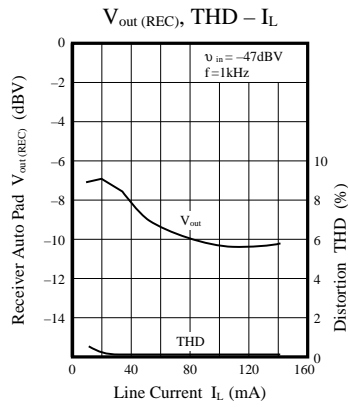
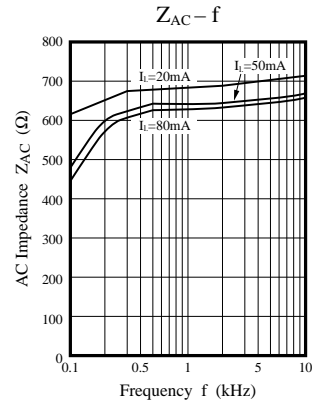
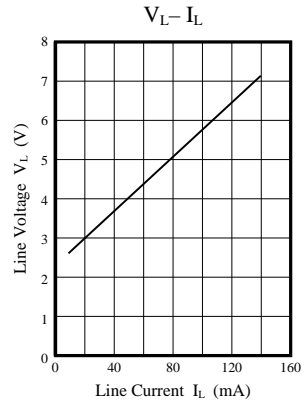

■ Application Circuits

- In case of using ceramic receiver

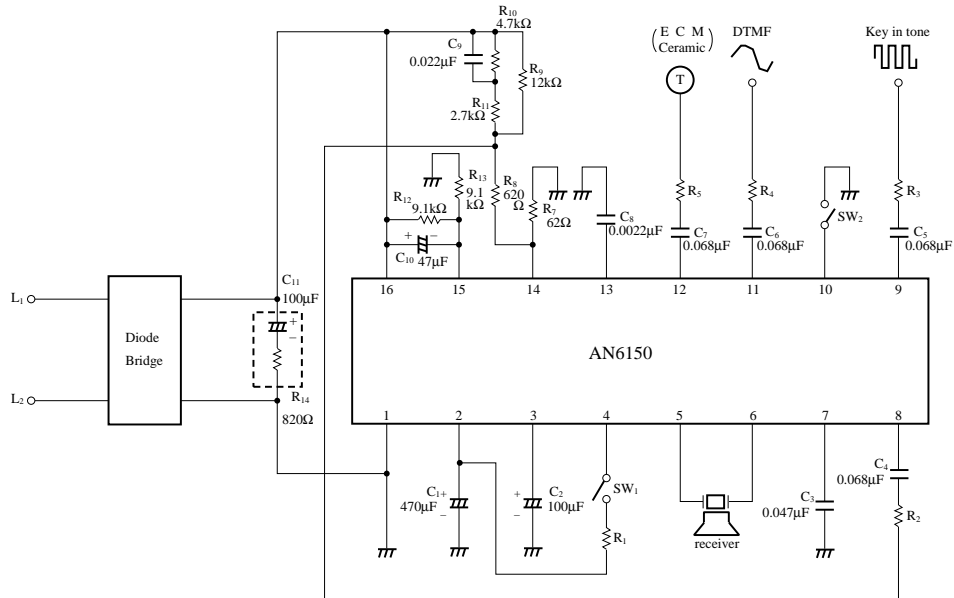

- In case of using low impedance receiver

