

### Features

- Operating voltage: 2.5V~5.5V
- Minimal external components
- No external filter is required
- Low standby current (on power down mode)
- Excellent performance
- Tristate data output for MCU interface
- 3.58MHz crystal or ceramic resonator
- 1633Hz can be inhibited by the INH pin
- HT9170B: 18-pin DIP package
- HT9170D: 18-pin SOP package

### General Description

The HT9170B/D are Dual Tone Multi Frequency (DTMF) receivers integrated with digital decoder and bandsplit filter functions as well as power-down mode and inhibit mode operations. Such devices use digital counting techniques to detect and decode all the 16 DTMF tone pairs into a 4-bit code output.

Highly accurate switched capacitor filters are implemented to divide tone signals into low and high group signals. A built-in dial tone rejection circuit is provided to eliminate the need for pre-filtering.

### Selection Table

Function Part No.	Operating Voltage	OSC Frequency	Tristate Data Output	Power Down	1633Hz Inhibit	DV	DVB	Package
HT9170B	2.5V~5.5V	3.58MHz	√	√	√	√	—	18 DIP
HT9170D	2.5V~5.5V	3.58MHz	√	√	√	√	—	18 SOP

### Block Diagram

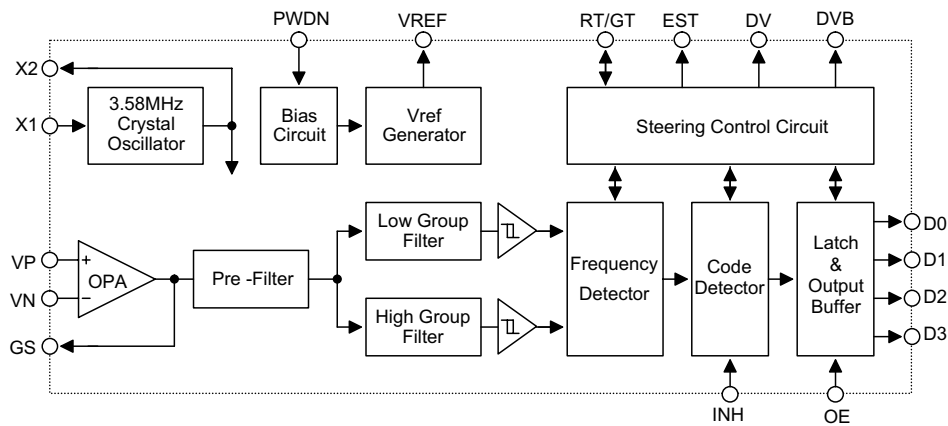

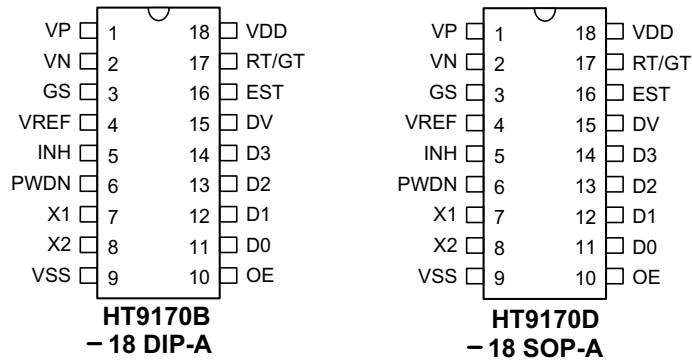
**Pin Assignment**

**Pin Description**

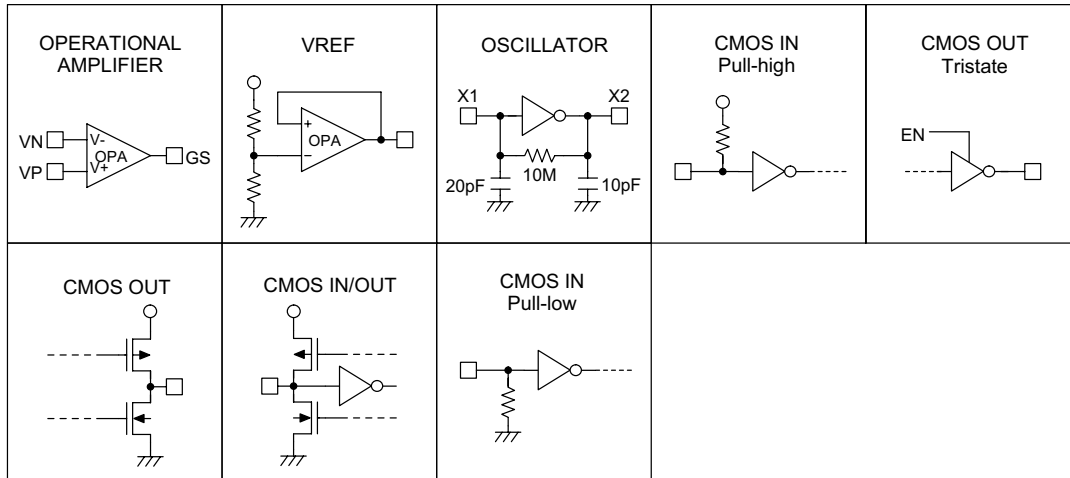
Pin Name	I/O	Internal Connection	Description
VP	I	Operational Amplifier	Operational amplifier non-inverting input
VN	I		Operational amplifier inverting input
GS	O		Operational amplifier output terminal
VREF	O	VREF	Reference voltage output, normally $V_{DD}/2$
X1	I	oscillator	The system oscillator consists of an inverter, a bias resistor and the necessary load capacitor on chip. A standard 3.579545MHz crystal connected to X1 and X2 terminals implements the oscillator function.
X2	O		
PWDN	I	CMOS IN Pull-low	Active high. This enables the device to go into power down mode and inhibits the oscillator. This pin input is internally pulled down.
INH	I	CMOS IN Pull-low	Logic high. This inhibits the detection of tones representing characters A, B, C and D. This pin input is internally pulled down.
VSS	—	—	Negative power supply, ground
OE	I	CMOS IN Pull-high	D0~D3 output enable, high active
D0~D3	O	CMOS OUT Tristate	Receiving data output terminals OE="H": Output enable OE="L": High impedance
DV	O	CMOS OUT	Data valid output When the chip receives a valid tone (DTMF) signal, the DV goes high; otherwise it remains low.
EST	O	CMOS OUT	Early steering output (see Functional Description)
RT/GT	I/O	CMOS IN/OUT	Tone acquisition time and release time can be set through connection with external resistor and capacitor.
VDD	—	—	Positive power supply, 2.5V~5.5V for normal operation

**Approximate internal connection circuits**

**Absolute Maximum Ratings**

Supply Voltage .....	-0.3V to 6V	Storage Temperature .....	-50°C to 125°C
Input Voltage .....	$V_{SS}-0.3V$ to $V_{DD}+0.3V$	Operating Temperature .....	-20°C to 75°C

Note: These are stress ratings only. Stresses exceeding the range specified under "Absolute Maximum Ratings" may cause substantial damage to the device. Functional operation of this device at other conditions beyond those listed in the specification is not implied and prolonged exposure to extreme conditions may affect device reliability.

**D.C. Characteristics**

Ta=25°C

Symbol	Parameter	Test Conditions		Min.	Typ.	Max.	Unit
		V <sub>DD</sub>	Conditions				
V <sub>DD</sub>	Operating Voltage	—	—	2.5	5	5.5	V
I <sub>DD</sub>	Operating Current	5V	—	—	3.0	7	mA
I <sub>STB</sub>	Standby Current	5V	PWDN=5V	—	10	25	μA
V <sub>IL</sub>	"Low" Input Voltage	5V	—	—	—	1.0	V
V <sub>IH</sub>	"High" Input Voltage	5V	—	4.0	—	—	V
I <sub>IL</sub>	"Low" Input Current	5V	V <sub>VP</sub> =V <sub>VN</sub> =0V	—	—	0.1	μA
I <sub>IH</sub>	"High" Input Current	5V	V <sub>VP</sub> =V <sub>VN</sub> =5V	—	—	0.1	μA
R <sub>OE</sub>	Pull-high Resistance (OE)	5V	V <sub>OE</sub> =0V	60	100	150	kΩ
R <sub>IN</sub>	Input Impedance (VN, VP)	5V	—	—	10	—	MΩ
I <sub>OH</sub>	Source Current (D0~D3, EST, DV)	5V	V <sub>OUT</sub> =4.5V	-0.4	-0.8	—	mA
I <sub>OL</sub>	Sink Current (D0~D3, EST, DV)	5V	V <sub>OUT</sub> =0.5V	1.0	2.5	—	mA
f <sub>OSC</sub>	System Frequency	5V	Crystal=3.5795MHz	3.5759	3.5795	3.5831	MHz

**A.C. Characteristics**
 $f_{osc}=3.5795\text{MHz}$ ,  $T_a=25^\circ\text{C}$ 

Symbol	Parameter	Test Conditions		Min.	Typ.	Max.	Unit
		V <sub>DD</sub>	Conditions				
<b>DTMF Signal</b>							
	Input Signal Level	3V		-36	—	-6	dBm
		5V		-29	—	1	
	Twist Accept Limit (Positive)	5V		—	10	—	dB
	Twist Accept Limit (Negative)	5V		—	10	—	dB
	Dial Tone Tolerance	5V		—	18	—	dB
	Noise Tolerance	5V		—	-12	—	dB
	Third Tone Tolerance	5V		—	-16	—	dB
	Frequency Deviation Acceptance	5V		—	—	±1.5	%
	Frequency Deviation Rejection	5V		±3.5	—	—	%
t <sub>PU</sub>	Power Up Time (See Figure 4.)	5V		—	30	—	ms
<b>Gain Setting Amplifier</b>							
R <sub>IN</sub>	Input Resistance	5V	—	—	10	—	MΩ
I <sub>IN</sub>	Input Leakage Current	5V	V <sub>SS</sub> <(V <sub>VP</sub> , V <sub>VN</sub> )<V <sub>DD</sub>	—	0.1	—	μA
V <sub>OS</sub>	Offset Voltage	5V	—	—	±25	—	mV
P <sub>SRR</sub>	Power Supply Rejection	5V	100 Hz -3V<V <sub>IN</sub> <3V	—	60	—	dB
C <sub>MRR</sub>	Common Mode Rejection	5V		—	60	—	dB
A <sub>VO</sub>	Open Loop Gain	5V		—	65	—	dB
f <sub>T</sub>	Gain Band Width	5V	—	—	1.5	—	MHz
V <sub>OUT</sub>	Output Voltage Swing	5V	R <sub>L</sub> >100kΩ	—	4.5	—	V <sub>PP</sub>
R <sub>L</sub>	Load Resistance (GS)	5V	—	—	50	—	kΩ
C <sub>L</sub>	Load Capacitance (GS)	5V	—	—	100	—	pF
V <sub>CM</sub>	Common Mode Range	5V	No load	—	3.0	—	V <sub>PP</sub>
<b>Steering Control</b>							
t <sub>DP</sub>	Tone Present Detection Time			5	16	22	ms
t <sub>DA</sub>	Tone Absent Detection Time			—	4	8.5	ms
t <sub>ACC</sub>	Acceptable Tone Duration			—	—	42	ms
t <sub>REJ</sub>	Rejected Tone Duration			20	—	—	ms
t <sub>IA</sub>	Acceptable Inter-digit Pause			—	—	42	ms
t <sub>IR</sub>	Rejected Inter-digit Pause			20	—	—	ms
t <sub>PDO</sub>	Propagation Delay (RT/GT to DO)			—	8	11	μs
t <sub>PDV</sub>	Propagation Delay (RT/GT to DV)			—	12	—	μs
t <sub>DOV</sub>	Output Data Set Up (DO to DV)			—	4.5	—	μs
t <sub>DDO</sub>	Disable Delay (OE to DO)			—	300	—	ns
t <sub>EDO</sub>	Enable Delay (OE to DO)			—	50	60	ns

Note: DO=D0~D3

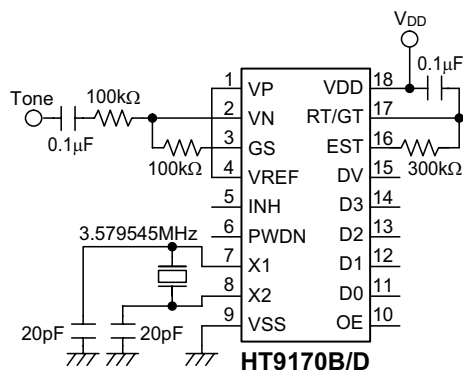

Figure 1. Test circuit

## Functional Description

### Overview

The HT9170B/D tone decoders consist of three band pass filters and two digital decode circuits to convert a tone (DTMF) signal into digital code output.

An operational amplifier is built-in to adjust the input signal (refer to Figure 2).

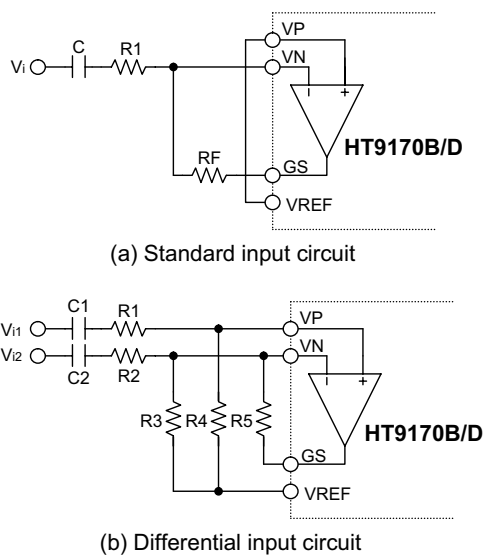

Figure 2. Input operation for amplifier application circuits

The pre-filter is a band rejection filter which reduces the dialing tone from 350Hz to 400Hz.

The low group filter filters low group frequency signal output whereas the high group filter filters high group frequency signal output.

Each filter output is followed by a zero-crossing detector with hysteresis. When each signal amplitude at the output exceeds the specified level, it is transferred to full swing logic signal.

When input signals are recognized to be effective, DV becomes high, and the correct tone code (DTMF) digit is transferred.

### Steering control circuit

The steering control circuit is used for measuring the effective signal duration and for protecting against drop out of valid signals. It employs the analog delay by external RC time-constant controlled by EST.

The timing is shown in Figure 3. The EST pin is normally low and draws the RT/GT pin to keep low through discharge of external RC. When a valid tone input is detected, EST goes high to charge RT/GT through RC.

When the voltage of RT/GT changes from 0 to  $V_{TRT}$  (2.35V for 5V supply), the input signal is effective, and the correct code will be created by the code detector. After D0~D3 are completely latched, DV output becomes high. When the voltage of RT/GT falls down from VDD to  $V_{TRT}$  (i.e., when there is no input tone), DV output becomes low, and D0~D3 keeps data until a next valid tone input is produced.

By selecting adequate external RC value, the minimum acceptable input tone duration ( $t_{ACC}$ ) and the minimum acceptable inter-tone rejection ( $t_{IR}$ ) can be set. External components (R, C) are chosen by the formula (refer to Figure 5):

$$t_{ACC} = t_{DP} + t_{GTP};$$

$$t_{IR} = t_{DA} + t_{GTA};$$

where  $t_{ACC}$ : Tone duration acceptable time

$t_{DP}$ : EST output delay time ("L"→"H")

$t_{GTP}$ : Tone present time

$t_{IR}$ : Inter-digit pause rejection time

$t_{DA}$ : EST output delay time ("H"→"L")

$t_{GTA}$ : Tone absent time

Timing Diagrams

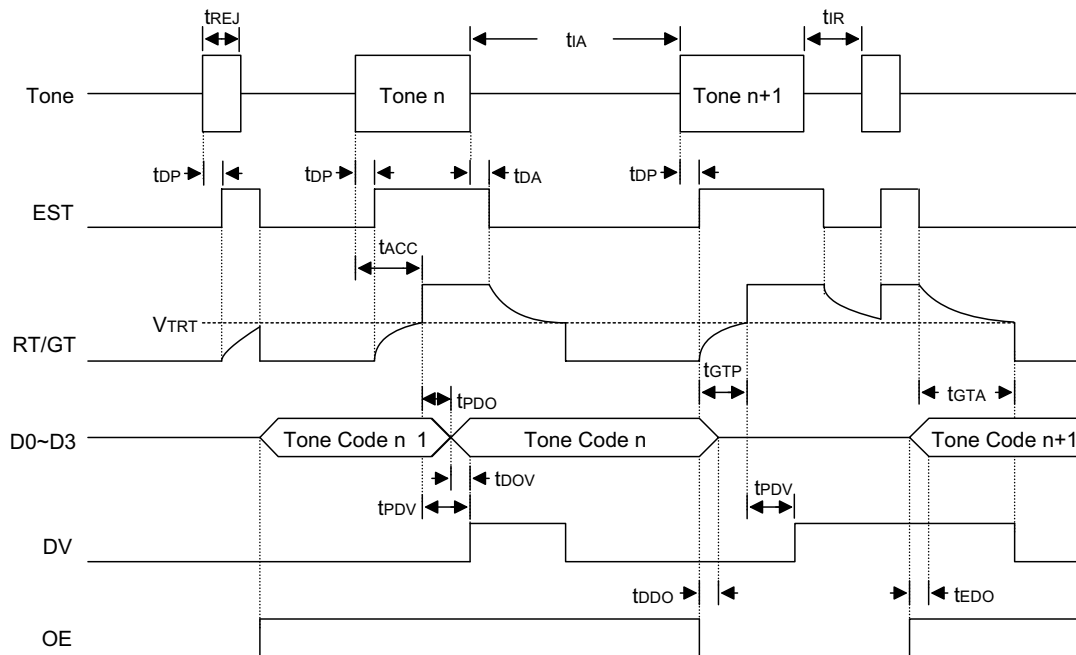

Figure 3. Steering timing

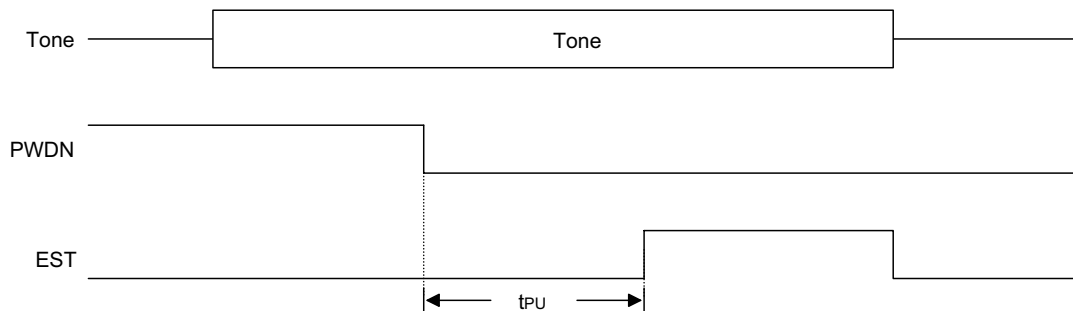
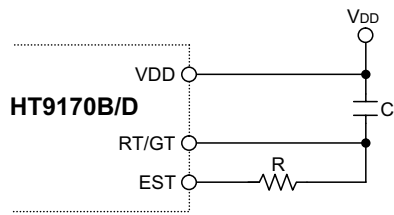

Figure 4. Power up timing



(a) Fundamental circuit:

$$t_{GTP} = R \times C \times \ln(V_{DD} / (V_{DD} - V_{TRT}))$$

$$t_{GTA} = R \times C \times \ln(V_{DD} / V_{TRT})$$

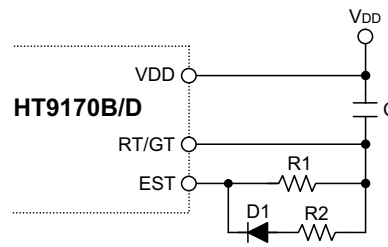

(c)  $t_{GTP} > t_{GTA}$  :

$$t_{GTP} = R1 \times C \times \ln(V_{DD} / (V_{DD} - V_{TRT}))$$

$$t_{GTA} = (R1 // R2) \times C \times \ln(V_{DD} / V_{TRT})$$

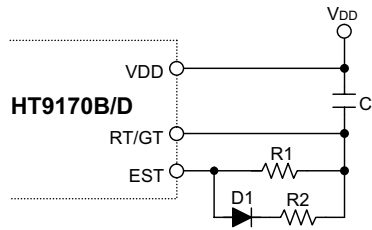

(b)  $t_{GTP} < t_{GTA}$  :

$$t_{GTP} = (R1 // R2) \times C \times \ln(V_{DD} - V_{TRT})$$

$$t_{GTA} = R1 \times C \times \ln(V_{DD} / V_{TRT})$$

Figure 5. Steering time adjustment circuits

**DTMF dialing matrix**

	COL1	COL2	COL3	COL4
ROW1	1	2	3	A
ROW2	4	5	6	B
ROW3	7	8	9	C
ROW4	*	0	#	D

**DTMF data output table**

Low Group (Hz)	High Group (Hz)	Digit	OE	D3	D2	D1	D0
697	1209	1	H	L	L	L	H
697	1336	2	H	L	L	H	L
697	1477	3	H	L	L	H	H
770	1209	4	H	L	H	L	L
770	1336	5	H	L	H	L	H
770	1477	6	H	L	H	H	L
852	1209	7	H	L	H	H	H
852	1336	8	H	H	L	L	L
852	1477	9	H	H	L	L	H
941	1336	0	H	H	L	H	L
941	1209	*	H	H	L	H	H
941	1477	#	H	H	H	L	L
697	1633	A	H	H	H	L	H
770	1633	B	H	H	H	H	L
852	1633	C	H	H	H	H	H
941	1633	D	H	L	L	L	L
—	—	ANY	L	Z	Z	Z	Z

Note: "Z" High impedance; "ANY" Any digit

**Data output**

The data outputs (D0~D3) are tristate outputs. When OE input becomes low, the data outputs (D0~D3) are high impedance.

**Application Circuits**

**Application Circuit 1**

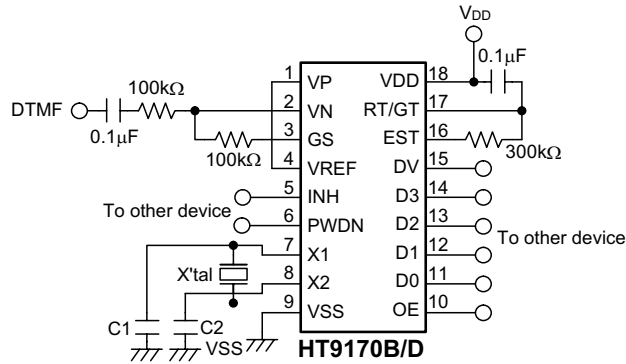

Note: X'tal = 3.579545MHz crystal  
 C1 = C2 ≅ 20pF  
 X'tal = 3.58MHz ceramic resonator  
 C1 = C2 ≅ 39pF

**Application Circuit 2**

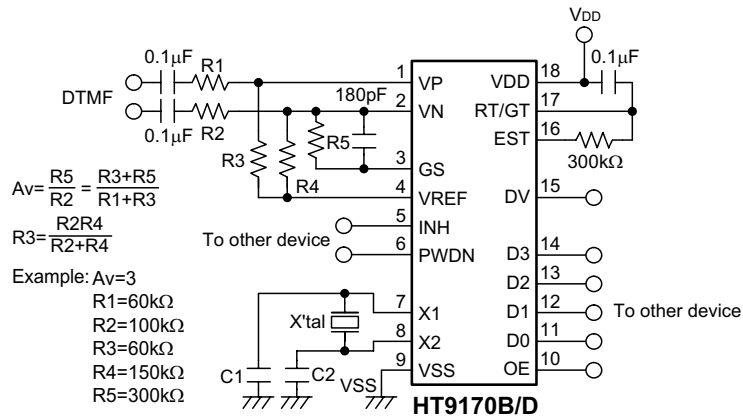

Note: X'tal = 3.579545MHz crystal  
 C1 = C2 ≅ 20pF  
 X'tal = 3.58MHz ceramic resonator  
 C1 = C2 ≅ 39pF



**Package Information**

18-pin DIP (300mil) outline dimensions

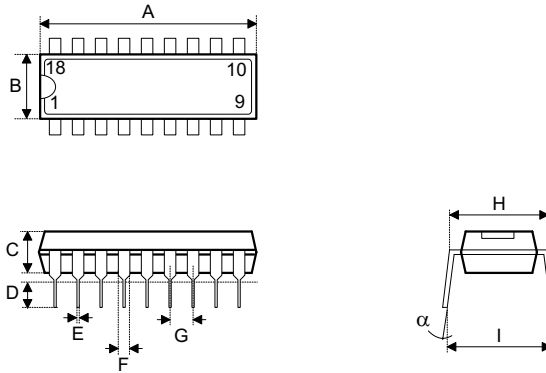

Symbol	Dimensions in mil		
	Min.	Nom.	Max.
A	895	—	915
B	240	—	260
C	125	—	135
D	125	—	145
E	16	—	20
F	50	—	70
G	—	100	—
H	295	—	315
I	335	—	375
$\alpha$	0°	—	15°

**18-pin SOP (300mil) outline dimensions**

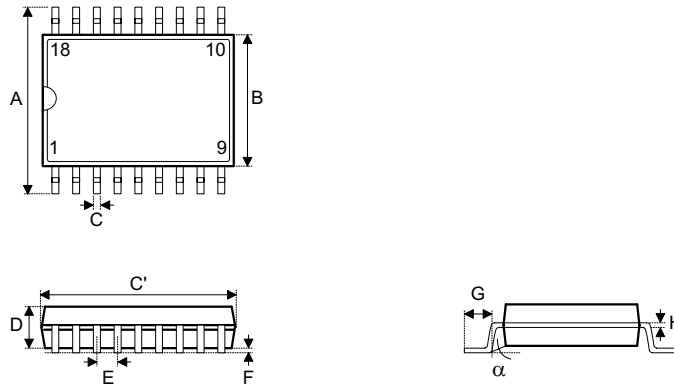

Symbol	Dimensions in mil		
	Min.	Nom.	Max.
A	394	—	419
B	290	—	300
C	14	—	20
C'	447	—	460
D	92	—	104
E	—	50	—
F	4	—	—
G	32	—	38
H	4	—	12
$\alpha$	0°	—	10°

**Product Tape and Reel Specifications**

**Reel dimensions**

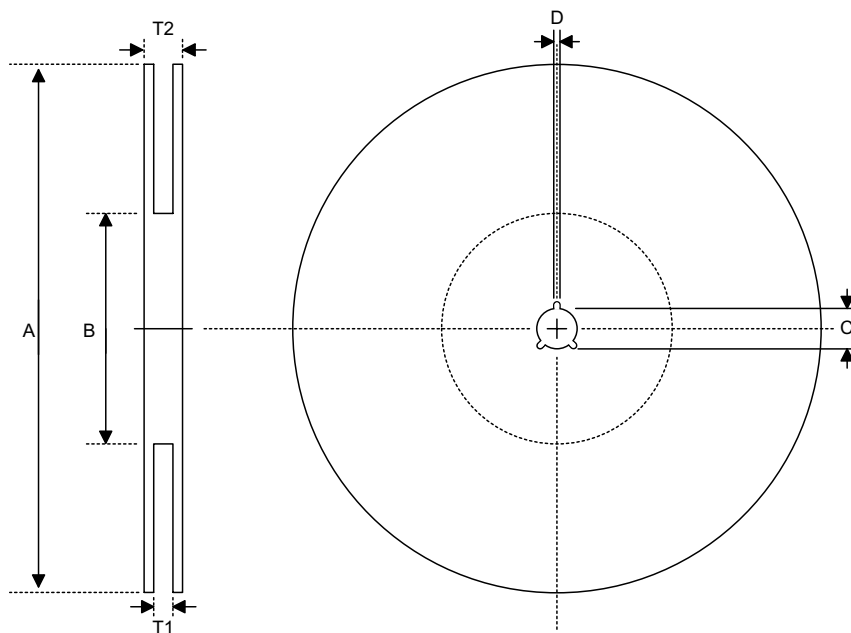

SOP 18W

Symbol	Description	Dimensions in mm
A	Reel Outer Diameter	330±1.0
B	Reel Inner Diameter	62±1.5
C	Spindle Hole Diameter	13.0+0.5 -0.2
D	Key Slit Width	2.0±0.5
T1	Space Between Flange	24.8+0.3 -0.2
T2	Reel Thickness	30.2±0.2

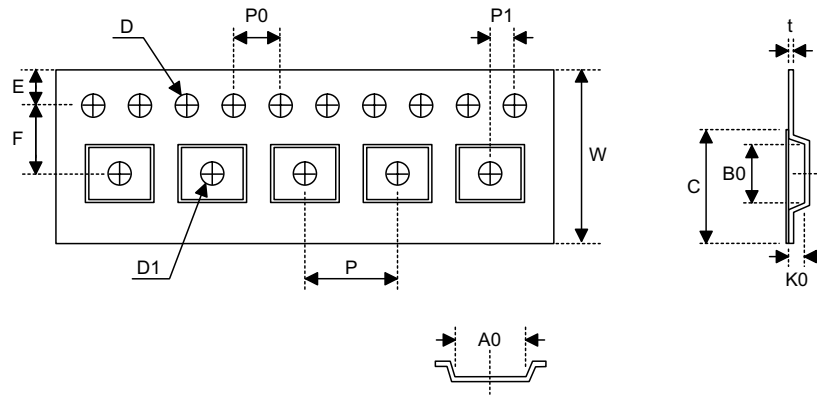
**Carrier tape dimensions**

**SOP 18W**

Symbol	Description	Dimensions in mm
W	Carrier Tape Width	24.0+0.3 -0.1
P	Cavity Pitch	16.0±0.1
E	Perforation Position	1.75±0.1
F	Cavity to Perforation (Width Direction)	11.5±0.1
D	Perforation Diameter	1.5±0.1
D1	Cavity Hole Diameter	1.5+0.25
P0	Perforation Pitch	4.0±0.1
P1	Cavity to Perforation (Length Direction)	2.0±0.1
A0	Cavity Length	10.9±0.1
B0	Cavity Width	12.0±0.1
K0	Cavity Depth	2.8±0.1
t	Carrier Tape Thickness	0.3±0.05
C	Cover Tape Width	21.3

**Holtek Semiconductor Inc. (Headquarters)**

No.3, Creation Rd. II, Science-based Industrial Park, Hsinchu, Taiwan  
Tel: 886-3-563-1999  
Fax: 886-3-563-1189  
<http://www.holtek.com.tw>

**Holtek Semiconductor Inc. (Sales Office)**

11F, No.576, Sec.7 Chung Hsiao E. Rd., Taipei, Taiwan  
Tel: 886-2-2782-9635  
Fax: 886-2-2782-9636  
Fax: 886-2-2782-7128 (International sales hotline)

**Holtek Semiconductor (Shanghai) Inc.**

7th Floor, Building 2, No.889, Yi Shan Rd., Shanghai, China  
Tel: 021-6485-5560  
Fax: 021-6485-0313  
<http://www.holtek.com.cn>

**Holtek Semiconductor (Hong Kong) Ltd.**

RM.711, Tower 2, Cheung Sha Wan Plaza, 833 Cheung Sha Wan Rd., Kowloon, Hong Kong  
Tel: 852-2-745-8288  
Fax: 852-2-742-8657

**Holmate Semiconductor, Inc.**

46712 Fremont Blvd., Fremont, CA 94538  
Tel: 510-252-9880  
Fax: 510-252-9885  
<http://www.holmate.com>

Copyright © 2002 by HOLTEK SEMICONDUCTOR INC.

The information appearing in this Data Sheet is believed to be accurate at the time of publication. However, Holtek assumes no responsibility arising from the use of the specifications described. The applications mentioned herein are used solely for the purpose of illustration and Holtek makes no warranty or representation that such applications will be suitable without further modification, nor recommends the use of its products for application that may present a risk to human life due to malfunction or otherwise. Holtek's products are not authorized for use as critical components in life support devices or systems. Holtek reserves the right to alter its products without prior notification. For the most up-to-date information, please visit our web site at <http://www.holtek.com.tw>.