

Features

- FM Double-conversion System
- Integrated Second IF Filter with Software-controlled Bandwidth
- Completely Integrated FM Demodulator
- Soft Mute and Multipath Noise Cancellation
- Receiving Condition Analyzer
- AM Up/Down-conversion System
- AM Preamplifier with AGC and Stereo Capability
- 3-wire Bus Controlled
- Search Stop Signal Generation for AM and FM
- Automatic Alignment Possible

Electrostatic sensitive device.
Observe precautions for handling.



Description

The U4255BM-M is a highly integrated AM/FM front-end circuit manufactured using Atmel's advanced BICMOS technology. It represents a complete, automatically adjustable AM/FM front end, containing a double-conversion system for FM and an up/down-conversion receiver for AM with IF1 = 10.7 MHz and IF2 = 450 kHz. The front end is suitable for digital or analog AF-signal processing. Together with the PLL U4256BM, an automatically aligned high-performance AM/FM tuner can be built. These ICs are dedicated for highly sophisticated car radio applications.

Pin Configuration

Figure 1. Pinning SSO44

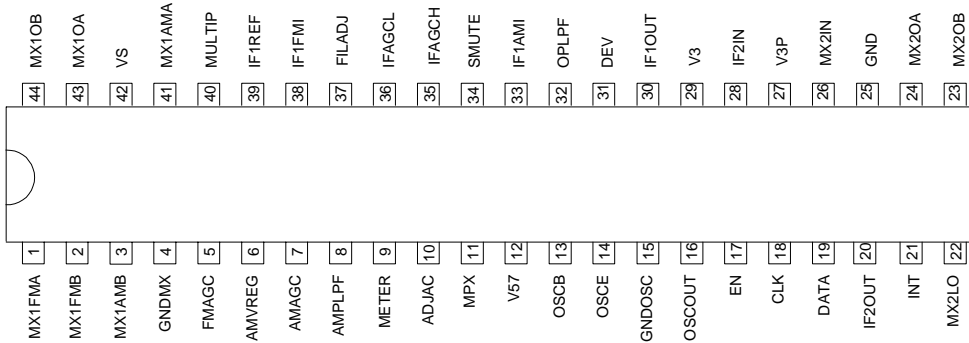

AM/FM Receiver IC

U4255BM-M

Preliminary

Rev. 4519C-AUDR-07/02



Pin Description

Pin	Symbol	Function
1	MX1FMA	1 st mixer FM input A
2	MX1FMB	1 st mixer FM input B
3	MX1AMB	1 st mixer AM input B
4	GNDMX	Ground 1 st mixer, preamplifier AGC
5	FMAGC	FM preamplifier AGC
6	AMVREG	AM control voltage
7	AMAGC	AM preamplifier AGC
8	AMPLPF	AM AGC LP filter
9	METER	Field strength output
10	ADJAC	Adjacent channel detection output
11	MPX	Multiplex signal
12	V57	5.7 V reference voltage
13	OSCB	Oscillator basis
14	OSCE	Oscillator emitter
15	GNDOSC	Oscillator ground
16	OSCOUT	Oscillator output
17	EN	3-wire bus enable
18	CLK	3-wire bus clock
19	DATA	3-wire bus data
20	IF2OUT	2 nd IF amplifier output
21	INT	Interrupt, stop signal
22	MX2LO	10.25 MHz input for 2 nd mixer
23	MX2OB	2 nd mixer output B
24	MX2OA	2 nd mixer output A
25	GND	Ground
26	MX2IN	2 nd mixer input
27	V3P	3 V reference for AMPIN, AMIFAGC, Control, IF2IN
28	IF2IN	2 nd IF amplifier input
29	V3	3 V reference for IF1OUT, MX2IN
30	IF1OUT	1 st IF amplifier output
31	DEV	Deviation detect output, test output
32	OPLPF	Operating point LPF
33	IF1AMI	1 st IF AM amplifier input
34	SMUTE	Soft MUTE control input
35	IFAGCH	IF AGC LP filter high time
36	IFAGCL	IF AGC LP filter low time constant
37	FILADJ	Filter adjust
38	IF1FMI	1 st IF FM amplifier input
39	IF1REF	1 st IF & MX1OUT reference, MX1AM A, MX1AM B
40	MULTIP	Multipath detection output
41	MX1AMA	1 st mixer AM input A
42	VS	Supply voltage
43	MX1OA	1 st mixer output A
44	MX1OB	1 st mixer output B

Figure 2. Block Diagram

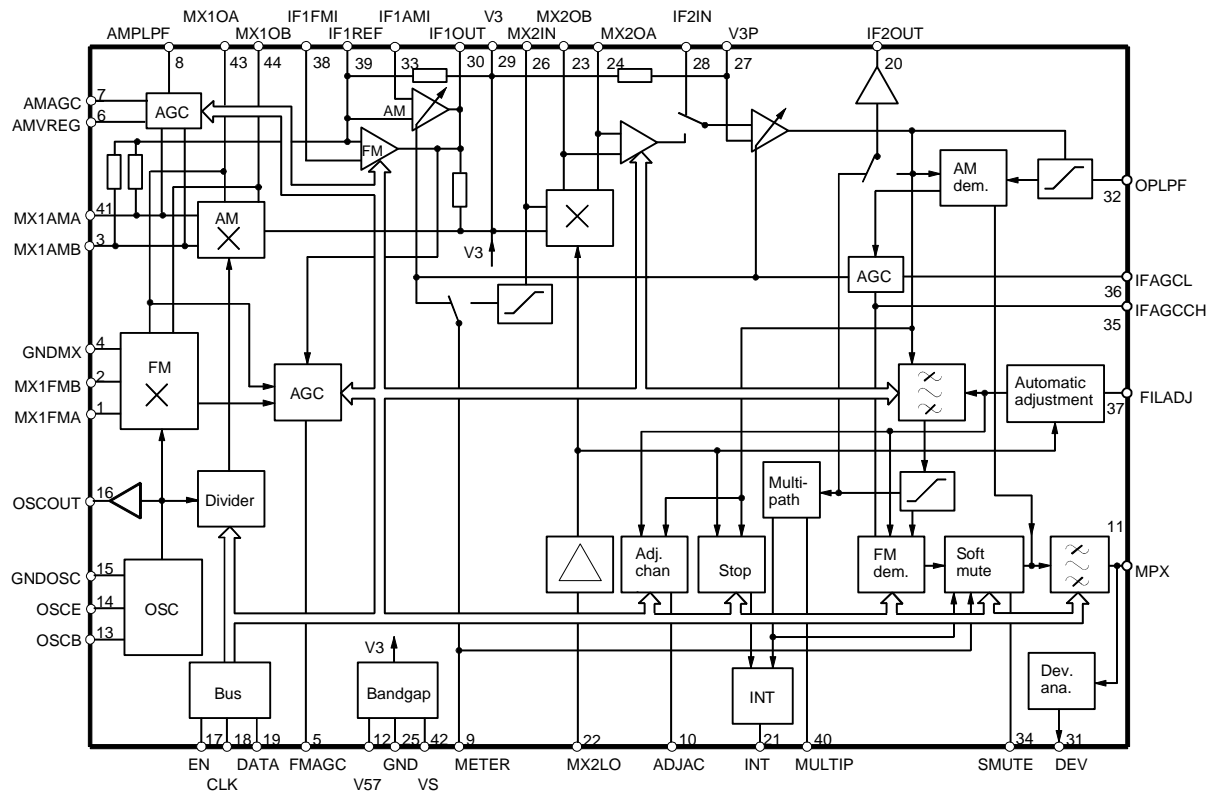

Functional Description

The U4255BM-M implements an AM up/down-conversion reception path from the RF input signal to the AM-demodulated audio frequency output signal, and for FM reception a double-conversion reception path from the RF input signal to the FM-demodulated multiplex signal (MPX). A VCO and an LO prescaler for AM are integrated to generate the LO frequency for the 1st mixer. Automatic gain control (AGC) circuits are implemented to control the preamplifier and IF stages in the AM and FM reception path.

For improved FM performance, an integrated IF filter with adjustable bandwidth, a soft-mute feature and an automatic multipath noise cancellation (MNC) circuit are fully integrated. A powerful set of sensors is provided for receiving condition analysis and stop signal generation.

Several register bits (Bit 0 to Bit 93) are used to control circuit operation and to adapt certain circuit parameters to the specific application. The control bits are organized in two 8-bit and three 24-bit registers that can be programmed by the 3-wire bus protocol. The bus protocol and the bit-to-register mapping is described in the section '3-wire Bus Description'. The meaning of the control bits is mentioned in the following sections.

Reception Mode

The IC can be operated in four different modes. Mode AM, FM, WB, Standby are selected by means of Bit 92 and Bit 93 according to Table 1.

In AM mode the AM mixer, the AM RF-AGC and the 1st IF AM amplifier at Pin 33 are activated. The input of the 2nd IF amplifier is connected to Pin 28 and the output of the 2nd IF amplifier is fed to the AM demodulator. The output of the AM demodulator is available at MPX output Pin 11.

In FM mode the FM mixer, the FM RF-AGC and the 1st IF FM amplifier at Pin 38 are activated. The bandwidth of the output tank at Pin 23, Pin 24 is increased and the input of the 2nd IF amplifier can be switched between Pin 23, Pin 24 and Pin 28. The output of the 2nd IF amplifier is fed to the integrated bandfilter and FM demodulator. The output of the FM demodulator is available at MPX output Pin 11.

WB mode is similar to FM mode but the input of the 2nd IF amplifier is fixed to Pin 28, the range of the bandwidth control of the integrated band filter is shifted to lower bandwidth and the gain of the FM demodulator is increased.

In standby mode the mixers, IF amplifiers and AGC circuits are deactivated to reduce current consumption.

Table 1. Operating Mode

AM/FM/Weather Channel	Bit 93	Bit 92
Standby	0	0
FM	0	1
AM	1	0
Weather band	1	1

Test Mode

A special test mode is implemented for final production test only. This mode is activated by setting Bit 9 = 1. **This mode is not intended to be used in customer application.** For normal operation, Bit 9 has to be set to 0. Bit 18 to Bit 30 are deactivated in normal operation mode.

Table 2. Test Mode

Mode	Bit 9
Normal operation	0
Testmode	1

VCO

An oscillator circuit is implemented to build a VCO as proposed in the application schematic. The VCO frequency is used to generate the LO frequency of the 1st mixer stages. The control voltage of the VCO is usually generated by the PLL circuit U4256BM. The VCO signal is provided at the buffered output Pin 16 to be fed to the PLL circuit.

FM RF-AGC

The FM RF-AGC circuit includes a wideband level detector at the input Pin 1 of the FM mixer and an in-band level detector at the output of the FM IF amplifier (Pin 30). The outputs of these level detectors are used to control the current into the pin diode (see Figure 3) in order to limit the signal level at the FM mixer input and the following stages. The maximum pin diode current is determined by R115 and the time constant of the AGC control loop can be adjusted by changing the value of C111.

The AGC threshold level at the input of the FM mixer can be adjusted by Bit 64 and Bit 65 according to Table 3. The in-band AGC threshold referred to the FM mixer input (Pin 1, Pin 2) depends on the gain of the FM IF amplifier and can be adjusted by Bit 89 to Bit 91.

Table 3. FM-AGC Threshold

FM-AGC Threshold	Bit 65	Bit 64
104 dB μ V	0	0
101 dB μ V	0	1
98 dB μ V	1	0
92 dB μ V	1	1

Figure 3. FM RF-AGC Bit 92

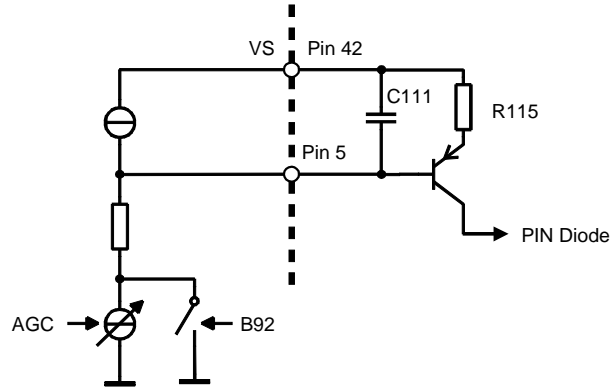

AM RF-AGC

The AM RF-AGC controls the current into the AM pin diodes (Pin 7) and the source drain voltage of the MOSFET in the AM preamplifier stage (Pin 6) to limit the level at the AM mixer input (Pin 3, Pin 41). This threshold level can be set by Bit 62 and Bit 63. If the level at the AM mixer input exceeds the selected threshold, the current into the AM pin diodes is increased. If this step is not sufficient, the source drain voltage of the MOSFET is decreased. The time constant of the AGC control loop can be adjusted by changing the value of the capacitor at Pin 8.

Table 4. AM-AGC Threshold

AM-AGC Threshold	Bit 63	Bit 62
99 dB μ V	0	0
102 dB μ V	0	1
104 dB μ V	1	0
105 dB μ V	1	1

FM 1st Mixer

In the 1st FM mixer stage, the FM reception frequency is down converted to the 1st IF frequency. The VCO frequency is used as LO frequency for the mixer.

AM 1st Mixer

The AM 1st mixer is used for up-conversion of the AM reception frequency to the 1st IF frequency. Therefore, an AM prescaler is implemented to generate the necessary LO frequency from the VCO frequency. The divide factor of the AM prescaler can be selected according to Table 5.

Table 5. Divide Factor of the AM Prescaler

Divider AM Prescaler	Bit 93	Bit 92	Bit 84	Bit 83	Bit 82	Bit 81
Divide by 10	1	0	x	0	0	0
Divide by 6	1	0	x	0	0	1
Divide by 7	1	0	x	0	1	0
Divide by 8	1	0	x	1	0	0
Divide by 4	1	0	x	1	0	1

FM 1st IF Amplifier

A programmable gain amplifier is used in FM and WB mode between Pin 38 and Pin 30 to compensate the loss in the external ceramic band filters. The gain of this amplifier is adjusted by Bit 89 to Bit 91. The input and the output resistance is 330 Ω and fits to external ceramic filters.

Two different temperature coefficients of the FM IF amplifier can be selected by Bit 66.

Table 6. Gain of the FM IF Amplifier

Gain FM IF	Bit 91	Bit 90	Bit 89
20 dB	0	0	0
22 dB	0	0	1
24 dB	0	1	0
26 dB	0	1	1
28 dB	1	0	0
29 dB	1	0	1
30 dB	1	1	0
31 dB	1	1	1

Table 7. Temperature Coefficient Setting of FM IF Amplifier

Temperature Coefficient (TC) of the IF Amplifier	Bit 66
TK _{min}	0
TK _{max}	1

AM 1st IF Amplifier

In AM mode, the gain of the 1st IF amplifier is controlled by the IF-AGC to extend the control range of the IF-AGC.

2nd Mixer

The 2nd mixer is used in AM, FM and WB mode. The mixer input has 330 Ω input resistance and can be connected directly to an external ceramic filter.

In FM mode, the high output resistance of the second mixer is reduced to increase the bandwidth of the tank at the mixer output. The output resistance can be selected by Bit 60 and Bit 61.

Table 8. 2nd Mixer Output Resistance in FM Mode

Bit 61	Bit 60	Output Resistance (Bit 54 = 0)	Output Resistance (Bit 54 = 1)
0	0	3.3 kΩ	~ 100 kΩ
0	1	0.63 kΩ	0.78 kΩ
1	0	0.47 kΩ	0.55 kΩ
1	1	0.29 kΩ	0.32 kΩ

The LO frequency of the 2nd mixer (10.25 MHz) has to be applied at Pin 22. This signal is usually generated by the PLL circuit U4256BM.

Table 9. FM Bandwidth Mixer 2

Bit 61	Bit 60	FM BW Mixer 2
0	0	150 kHz
0	1	200 kHz
1	0	250 kHz
1	1	450 kHz

Remark: The bandwidth is also depending from the values of the application circuit.

2nd IF Amplifier

In AM and WB mode, the input of the second IF amplifier is Pin 28, which is externally connected to the 2nd mixer tank through the AM ceramic filter to achieve channel selectivity. During normal FM operation (Bit 54 = 0), the input of the second IF amplifier is connected to the 2nd mixer output (Pin 23, Pin 24) and the integrated FM band filter is used for channel selectivity only. It is possible to use an additional external filter between the 2nd mixer tank and Pin 28 in FM mode by setting Bit 54 to 1.

Table 10. 2nd IF Filter in FM Mode

2nd IF Filter	Bit 54
Internal filter	0
External and internal filter	1

IF-AGC

The IF-AGC controls the level of the 2nd IF signal that is passed to the AM demodulator input or the integrated FM bandfilter and to the 2nd IF output Pin 20.

Two different time constants of the IF-AGC can be selected by the capacitors at Pin 35 (IFAGCH) and Pin 36 (IFAGCL). The short time constant (IFAGCL) is used in FM mode and in AM search mode. The long time constant (IFAGCH) is used for AM reception.

Table 11. IF-AGC Time Constant

Mode	Bit 92	Bit 88	IF AGC Time Constant
FM/WB	1	X	IFAGCL (fast)
AM reception	0	0	IFAGCH (slow)
AM search	0	1	IFAGCL (fast)

In FM/WB mode, the output signal of the FM demodulator is applied to Pin 35 via a series resistor of about 95 kΩ. This low-pass filtered output signal of the FM demodulator is used for the FM demodulator fine adjustment, for muting and as a reference for the deviation sensor.

2nd IF Output

The 2nd IF after the gain-controlled 2nd IF amplifier is available at Pin20 (Bit 55 = 0). In AM mode, this signal may be used for an external AM stereo decoder. Alternatively, a signal corresponding to the logarithmic field strength after the integrated FM band filter, which is used for multipath detection, can be switched to Pin 20 by setting Bit 55 = 1.

Table 12. Pin 20 Output Setting

Pin 20	Bit 55
2 nd IF output	0
Multipath field strength	1

Automatic IF Center Frequency Adjustment

Integrated active filters are used in the FM band filter, FM demodulator and adjacent channel sensor. The center frequency of these filters is automatically adjusted to the second IF frequency of 450 kHz. The frequency of 10.25 MHz at Pin 22 is used as a reference for this alignment.

Figure 4. Automatic IF Center Frequency Adjustment

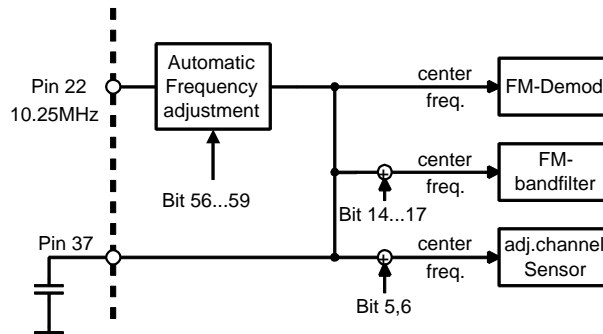

For fine tuning, the center frequency of all these integrated active filters (band filter, demodulator and adjacent channel sensor) can be shifted in steps of 6.25 kHz by means of Bit 56 to Bit 59. Additionally, the center frequency of the band filter can be adjusted separately by means of Bit 14 to Bit 17 if Bit 4 is set to 1. If Bit 4 is set to 0, the default setting is used.

Table 13. 2nd IF Center Frequency

IF Center	Bit 59	Bit 58	Bit 57	Bit 56
450.00 kHz	0	0	0	0
456.25 kHz	0	0	0	1
461.50 kHz	0	0	1	0
468.75 kHz	0	0	1	1
475.00 kHz	0	1	0	0
481.25 kHz	0	1	0	1
487.50 kHz	0	1	1	0
493.75 kHz	0	1	1	1
450.00 kHz	1	0	0	0
443.75 kHz	1	0	0	1
437.50 kHz	1	0	1	0
431.25 kHz	1	0	1	1
425.00 kHz	1	1	0	0
418.75 kHz	1	1	0	1
412.50 kHz	1	1	1	0
406.25 kHz	1	1	1	1

Table 14. FM Band Filter Center Frequency Correction

IF Correction	Bit 17	Bit 16	Bit 15	Bit 14
- 0 kHz	0	0	0	0
- 6.25 kHz	0	0	0	1
- 12.50 kHz	0	0	1	0
- 18.75 kHz	0	0	1	1
- 25.00 kHz	0	1	0	0
- 31.25 kHz	0	1	0	1
- 37.50 kHz	0	1	1	0
- 43.75 kHz	0	1	1	1
+ 0 kHz (default)	1	0	0	0
+ 6.25 kHz	1	0	0	1
+ 12.50 kHz	1	0	1	0
+ 18.75 kHz	1	0	1	1
+ 25.00 kHz	1	1	0	0
+ 31.25 kHz	1	1	0	1
+ 37.50 kHz	1	1	1	0
+ 43.75 kHz	1	1	1	1

Integrated FM Band Filter

For FM reception a band filter with variable bandwidth is integrated in front of the demodulator to provide channel selectivity on the 2nd IF. The bandwidth of this filter can be adjusted by Bit 0 to 3 (see Table 15) to be suitable for the present receiving condition. In WB mode, the bandwidth of the integrated filter is shifted to lower bandwidth values, while the necessary channel selectivity is achieved by an external ceramic filter.

The center frequency of the integrated FM band filter can be adjusted by means of Bit 14 to 17 (Bit 4 set to 1). The field strength after the integrated FM band filter that is available at Pin 20 (Bit55 = 1) can be used for this purpose.

Table 15. Bandwidth of the Integrated FM Band Filter.

IF Bandwidth	Bit 3	Bit 2	Bit 1	Bit 0
200 kHz	0	0	0	0
190 kHz	0	0	0	1
180 kHz	0	0	1	0
170 kHz	0	0	1	1
160 kHz	0	1	0	0
150 kHz	0	1	0	1
140 kHz	0	1	1	0
130 kHz	0	1	1	1
120 kHz	1	0	0	0
110 kHz	1	0	0	1
100 kHz	1	0	1	0
90 kHz	1	0	1	1
80 kHz	1	1	0	0
70 kHz	1	1	0	1
60 kHz	1	1	1	0
50 kHz	1	1	1	1

FM Demodulator

For weather band reception, the gain of the FM demodulator is increased and can be adjusted by means of Bit 71, Bit 72 in order to increase the output voltage to compensate the low frequency deviation in weather band.

An integrated demodulator fine adjustment allows automatic fine tuning of the demodulator center frequency to the average frequency of the received signal. This feature is implemented for use in weather band mode and can be activated by setting Bit 53 to 0.

Figure 5. FM Demodulator Automatic Fine Tuning

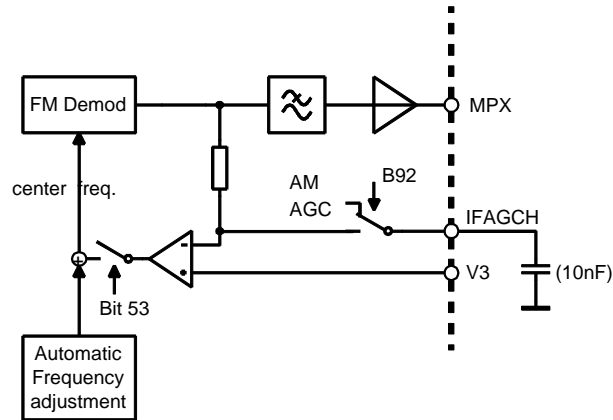

The center frequency of the FM demodulator can be adjusted by means of Bit 56 to 59. At the center frequency, the DC voltage at the MPX output Pin 11 is equal to the MPX offset voltage that can be measured at Pin 11 while MPX mute is active (Bit 7 = 1). This adjustment will affect the center frequency of all integrated filters as mentioned before.

Table 16. Demodulator Gain in Weather Band Mode

Demodulator Gain in Weather Band Mode Relative to FM Mode	Bit 72	Bit 71
12 dB	0	0
15 dB	0	1
18 dB	1	0
21 dB	1	1

Table 17. Demodulator Fine Adjustment

Demodulator Fine Adjustment	Bit 53
Fine tuning ON	0
Fine tuning OFF	1

Soft Mute

The soft mute functionality is implemented to reduce the output level of the FM demodulator at low input signal levels to limit the noise at MPX output in this case. If the input level falls below an adjustable threshold, continuously the output of the FM demodulator is continuously muted with decreasing input level until a maximum mute value is reached. The threshold for the start of soft mute and the maximum mute can be adjusted. The signal level for 3 dB mute can be set by means of Bit 68 to 70 and the maximum value for soft mute can be selected by Bit 67. The steepness and the time constant of the soft mute can be adjusted by the resistor and capacitor between Pin 34 and Pin 29.

The field strength signal available at Pin 9 is used for soft mute. Therefore, the soft mute threshold referred to the input of the FM mixer depends on the gain from FM mixer input to the field strength sensor.

Table 18. Soft Mute Threshold

Relative Soft Mute Threshold	Bit 70	Bit 69	Bit 68
Soft mute OFF	0	0	0
-18 dB	0	0	1
-15 dB	0	1	0
-12 dB	0	1	1
-9 dB	1	0	0
-6 dB	1	0	1
-3 dB	1	1	0
0 dB	1	1	1

Table 19. Maximum Soft Mute

Maximum Value of Soft Mute	Bit 67
28 dB	0
24 dB	1

Figure 6. Soft Mute

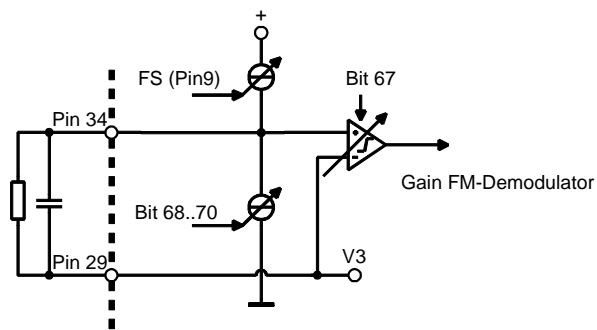

MPX Output

The output of the AM demodulator (AM mode) or the output of the FM demodulator (FM/WB mode) are available at the MPX output (Pin 11).

The MPX output signal can be muted by setting Bit 7 to 1.

The bandwidth of the lowpass filter at the MPX output can be set by means of Bit 79 to 90 kHz or 180 kHz.

Table 20. MPX Output Mute

MPX Output	Bit 7
MPX out, Pin 11 normal operation	0
Mute ON	1

Table 21. MPX Output Bandwidth

Bandwidth MPX Lowpass Filter	Bit 79
90 kHz	0
180 kHz	1

Receiving Condition Analyzer

The U4255BM-M implements several sensors that provide information about the receiving condition of the selected station.

Field Strength Sensor

The field strength sensor provides a DC voltage at Pin 9 which represents the logarithmic field strength of the signal in the reception band.

The field strength information can be retrieved either from a level detector at the input of the 2nd mixer (Pin 26) or from the IF-AGC depending on the setting of Bit 80. The bandwidth of the field strength detection in the AGC is smaller than by using the level detector because of additional selectivity between the 2nd mixer and the 2nd IF amplifier particularly in AM and WB, but the field strength detection in the AGC is limited to the IF AGC range. Usually the field strength from the level detector is used in FM mode and the AGC field strength is used in AM mode.

Table 22. Field Strength Selection

Field Strength Narrow Band / Wide Band	Bit 80
Fieldstrength at Pin 26 (wide band)	0
Fieldstrength from IF-AGC (narrow band)	1

Search Stop Detector

A search stop detector is available in AM and FM/WB mode. A STOP condition is signaled if the frequency of the ZF signal is within a window around the center frequency of 450 kHz. The width of this search stop window can be set by Bit 85 to 87 in the range of 0.5 kHz to 80 kHz. The frequency of the ZF signal is measured by counting the number of periods of the ZF signal during a measurement time which is determined by Bit 73 to 78. The inverted STOP signal is available at Pin 21 according to Table 25. The frequency of 10.25 MHz at Pin 22 is used as time reference.

Table 23. Search Stop Detector Measurement Time

Time Window for Stop Signal	Bit 78	Bit 77	Bit 76	Bit 75	Bit 74	Bit 73
1 × 3.1969 ms	0	0	0	0	0	1
.....						
63 × 3.1969 ms	1	1	1	1	1	1

Table 24. Search Stop Window

Search Stop Window	Bit 87	Bit 86	Bit 85
± 0.5 kHz	0	0	0
± 1.1 kHz	0	0	1
± 2.3 kHz	0	1	0
± 4.8 kHz	0	1	1
± 10 kHz	1	0	0
± 20 kHz	1	0	1
± 40 kHz	1	1	0
± 80 kHz	1	1	1

Table 25. Signals Available at Digital Output Pin 21

Bit 88	Bit 92	INT (Pin 21)
0	0 (AM)	1
0	1 (FM/WB)	NOT MPINT
1	0 (AM)	NOT STOP
1	1 (FM/WB)	NOT (STOP AND NOT MPINT)

Deviation Sensor

The deviation sensor is active in AM and FM/WB mode and measures the modulation of the signal. It is implemented as a peak detector of the lowpass-filtered MPX signal (see Figure 7). The output voltage at Pin 31 is proportional to the frequency deviation in FM/WB or the modulation depth in AM respectively.

Figure 7. Deviation Sensor

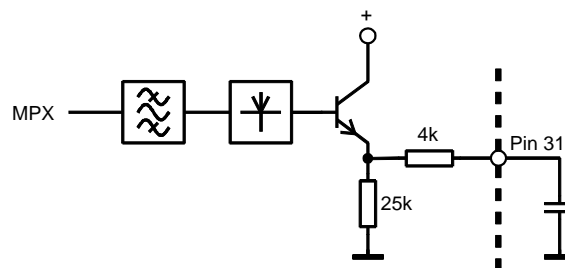

Adjacent Channel Sensor

The adjacent channel sensor is active in FM mode only and measures the field strength outside the reception band. By setting the center frequency of the band filter of the adjacent channel sensor below or above the 2nd IF frequency (Bit 5, Bit 6), it can be determined whether the disturbance signal is located above or below the reception frequency (see Table 28). The bandwidth of the band filter used in the adjacent channel sensor can be changed by means of Bit 10 to 13. If Bit 4 = 0 the default bandwidth setting is used. The output of the adjacent channel sensor is independent of the bandwidth setting of the integrated FM band filter.

Figure 8. Adjacent Channel Sensor

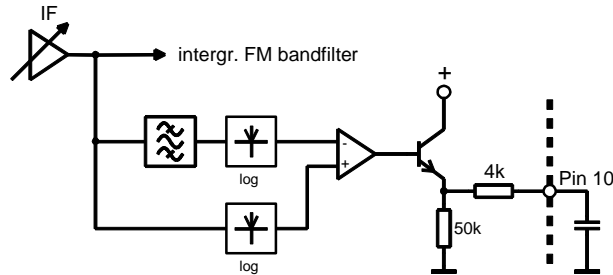

Table 26. Bandwidth of the Adjacent Channel Detector Filter

BW Adjustment	Bit 13	Bit 12	Bit 11	Bit 10
3 kHz	0	0	0	0
16 kHz	0	0	1	0
32 kHz	0	1	0	0
50 kHz	0	1	1	0
65 kHz	1	0	0	0
80 kHz	1	0	1	0
95 kHz	1	1	0	0
110 kHz	1	1	1	0
50 kHz	0	0	0	1
65 kHz	0	0	1	1
80 kHz (default)	0	1	0	1
95 kHz	0	1	1	1
110 kHz	1	0	0	1
130 kHz	1	0	1	1
145 kHz	1	1	0	1
160 kHz	1	1	1	1

Table 27. Center Frequency Adjacent Channel Sensor

Center Frequency	Bit 6	Bit 5
450 kHz	0	0
300 kHz	0	1
700 kHz	1	0
Filter OFF	1	1

Table 28. Output Voltage of Adjacent Channel Sensor for Different Receiving Conditions and Center Frequencies

Adjacent Channel Disturbance	300 kHz	450 kHz	600 kHz
no	high	low	high
below	high	high	low
above	low	high	high

Multipath Sensor

The multipath sensor is active in FM mode only and measures the disturbance due to multipath reception. The multipath sensor detects drops in the field strength after the integrated band filter by calculating the difference between an averaged maximum field strength and the current field strength. The maximum depth of these drops is represented by the voltage of the peak detector at Pin 40 (MULTIP). The level of this voltage represents the degree of disturbance in the received signal.

Figure 9. Multipath Sensor

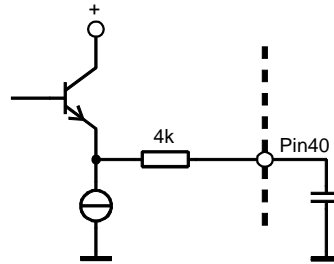

A Multipath Noise Canceller (MNC) is implemented to reduce disturbance of the received signal in multipath reception conditions. If the difference between the momentary and the averaged field strength falls below a threshold adjustable by Bit 81 to 84 (see Table 30), the MPX signal may be muted and this situation (MPINT) can be signalized at Pin 21 (INT) according to Table 25. Muting of the MPX signal during multipath disturbances can be activated by setting Bit 8.

Table 29. Multipath Noise Canceller

Multipath Noise Canceller	Bit 8
Active	0
Not active	1

Table 30. Sensitivity of the MNC

Sensitivity MNC (Threshold)	Bit 93	Bit 92	Bit 84	Bit 83	Bit 82	Bit 81
Off	x	1	0	0	0	0
Low	x	1	0	0	0	1
	x	1	0	0	1	0
(-18 dB)	x	1	0	0	1	1
	x	1	0	1	0	0
	x	1	0	1	0	1
	x	1	0	1	1	0
Normal (-12 dB)	x	1	0	1	1	1
	x	1	1	0	0	0
	x	1	1	0	0	1
	x	1	1	0	1	0
	x	1	1	0	1	1
	x	1	1	1	0	0
	x	1	1	1	0	1
	x	1	1	1	1	0
High (-9 dB)	x	1	1	1	1	1

3-wire Bus Description

The register settings of U4255BM-M are programmed by a 3-wire bus protocol. The bus protocol consists of separate commands. A defined number of bits is transmitted sequentially during each command.

One command is used to program all bits of one register. The different registers available (see Table 31) are addressed by the length of the command (number of transmitted bits) and by three address bits that are unique for each register of a given length. 8-bit registers are programmed by 8-bit commands and 24-bit registers are programmed by 24-bit commands.

Each bus command starts with a rising edge on the enable line (EN) and ends with a falling edge on EN. EN has to be kept HIGH during the bus command.

The sequence of transmitted bits during one command starts with the LSB of the first byte and ends with the MSB of the last byte of the register addressed. The DATA is evaluated at the rising edges of CLK. The number of LOW to HIGH transitions on CLK during the HIGH period of EN is used to determine the length of the command.

The bus protocol and the register addressing of U4255BM-M are compatible to the addressing used in U4256BM. That means U4255BM-M and U4256BM can be operated on the same 3-wire bus as shown in the application circuit.

Figure 10. Pulse Diagram

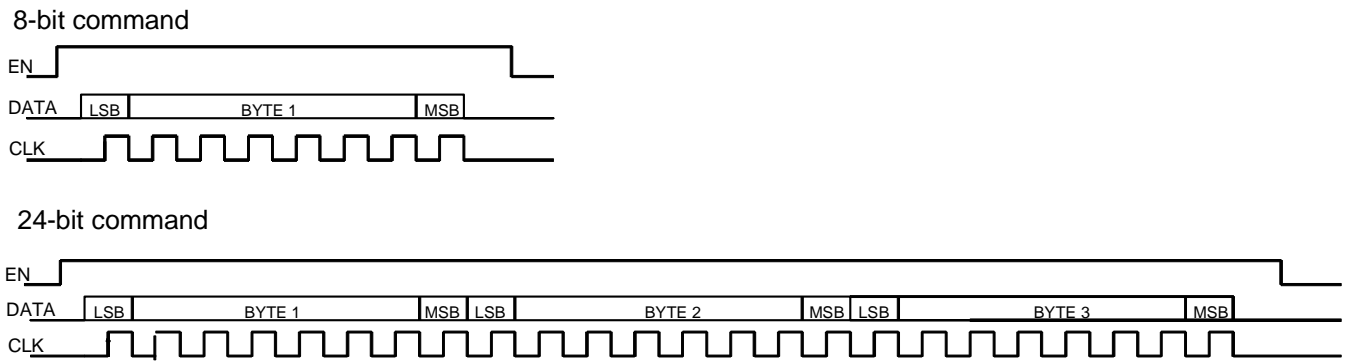
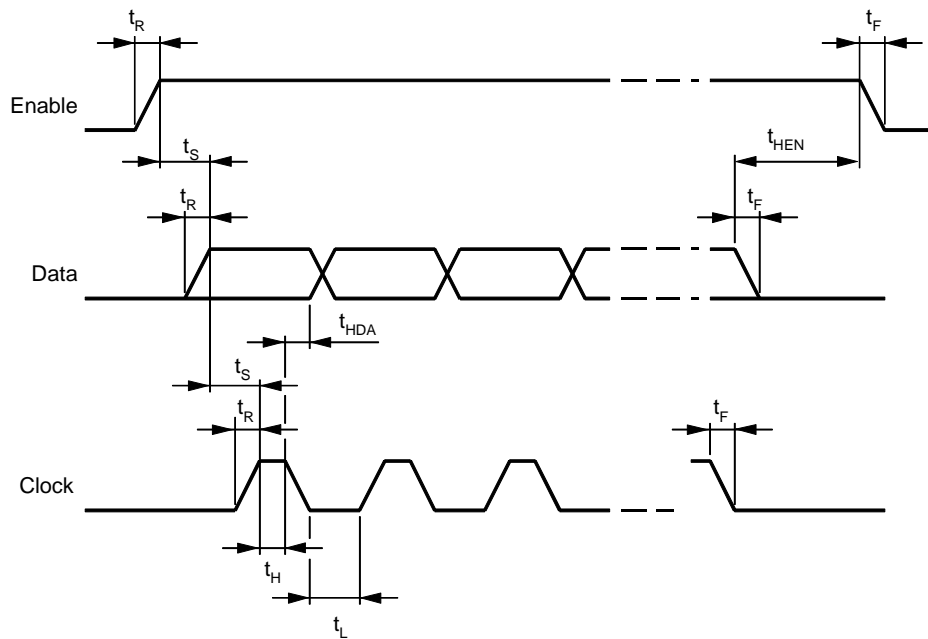

Figure 11. Bus Timing



Data Transfer

Table 31. Control Registers

A24_100																													
MSB			BYTE 3					LSB	MSB			BYTE 2						LSB	MSB			BYTE 1							LSB
ADDR.			AM/FM/WB		Gain FM IF amplifier			Search	Width of window			OSC divider/multipath sensitivity			Field strength	BWM PX	Time window stop signal												
1	0	0	AM	FM																									
			B9 3	B9 2	B9 1	B9 0	B8 9	B88	B8 7	B8 6	B8 5	B8 4	B8 3	B8 2	B8 1	B80	B79	B7 8	B7 7	B7 6	B7 5	B7 4	B7 3						

A24_101																													
MSB			BYTE 3					LSB	MSB			BYTE 2						LSB	MSB			BYTE 1							LSB
ADDR.			WB-Demod-Gain		Start Smute			Smute	Tk-FM IF	FM-AGC		AM-AGC		FM BW 2 nd mixer		IF2 center frequency			MP FS	FM ext	De m. Adj.	Not used							
1	0	1																											
			B7 2	B7 1	B7 0	B6 9	B6 8	B67	B66	B6 5	B6 4	B6 3	B6 2	B6 1	B6 0	B59	B58	B5 7	B5 6	B5 5	B5 4	B5 3	B5 2				x		

A24_111																													
MSB			BYTE 3					LSB	MSB			BYTE 2						LSB	MSB			BYTE 1							LSB
ADDR.			used in test mode only												center frequency of bandfilter				bandwidth adj. channel sensor										
1	1	1								x	x					1	0	0	0	0	1	0	1						
			B3 0	B2 9	B2 8	B2 7	B2 6	B25	B24	B2 3	B2 2	B2 1	B2 0	B1 9	B1 8	B17	B16	B1 5	B1 4	B1 3	B1 2	B1 1	B1 0						

A8_100									
MSB		BYTE 1						LSB	
ADDR.		Test	MP off	Mute	Adj. channel sensor				
1	0	0							
			B9	B8	B7	B6	B5		

A8_101									
MSB		BYTE 1						LSB	
ADDR.		Optimize		Band width					
1	0	1							
			B4	B3	B2	B1	B0		

Absolute Maximum Ratings

All voltages are referred to GND (Pin 25)

Parameters	Symbol	Value	Unit
Supply voltage Pin 42	V_S	10	V
Power dissipation	P_{tot}	1000	mW
Junction temperature	T_j	150	°C
Ambient temperature range	T_{amb}	-40 to +85	°C
Storage temperature range	T_{stg}	-50 to +150	°C

Thermal Resistance

Parameters	Symbol	Value	Unit
Junction ambient, soldered to PCB	R_{thJA}	60	K/W

Operating Range

All voltages are referred to GND (Pin 25)

Parameters	Symbol	Min.	Typ.	Max.	Unit
Supply voltage range Pin 42	V_S	7.5	8.5	10	V
Ambient temperature	T_{amb}	-40		+85	°C

Electrical Characteristics

Test conditions (unless otherwise specified): $V_S = 8.5$ V, $T_{amb} = 25$ °C.

No.	Parameters	Test Conditions	Pin	Symbol	Min.	Typ.	Max.	Unit	Type*
1	Power Supply								
1.1	Supply voltage		42	V_S	7.5	8.5	10	V	C
1.2	Supply current	Standby mode (Bit 92 = 0, Bit 93 = 0)	42	I_{Stby}		20	25	mA	A
1.3	Supply current	Other operation modes	42	I_S		50	60	mA	A
2	VCO								
2.1	Frequency range			f_{VCO}	70		160	MHz	D
2.2	DC bias voltage		13		2.8	3.0	3.2	V	A
2.3	Buffer output voltage	$f_{osc} = 120$ MHz	16		130	150	250	mVrms	A
2.4	Buffer output resistance		16			70		Ω	D
2.5	Buffer output DC voltage		16		2.8	3.0	3.2	V	A

*) Type means: A =100% tested, B = 100% correlation tested, C = Characterized on samples, D = Design parameter

Electrical Characteristics (Continued)

Test conditions (unless otherwise specified): $V_S = 8.5\text{ V}$, $T_{amb} = 25^\circ\text{C}$.

No.	Parameters	Test Conditions	Pin	Symbol	Min.	Typ.	Max.	Unit	Type*
3	FM RF-AGC								
3.1	Saturation voltage	No input signal	5		8.3			V	A
3.2	Saturation voltage	No input signal	5		$V_S-0.2$			V	B
3.3	Threshold level	In-band signal	30			110		$\text{dB}\mu\text{V}$	D
3.4	Maximum threshold level	Out-of-band signal (110 MHz), Bit 64, 65 = 0	1		100	102	104	$\text{dB}\mu\text{V}$	A
4	AM RF-AGC, AM Mode (Bit 92 = 0, Bit 93 = 1)								
4.1	Saturation voltage	No input signal	7		8.3			V	A
4.2	Saturation voltage	No input signal	7		$V_S-0.2$			V	B
4.3	Output voltage for minimum gain	Bit 92 = 1	7		6.5	6.8	7.1	V	A
4.4	Output voltage for minimum gain	Bit 92 = 1	7			$V_S-1.7$		V	B
4.5	Maximum control voltage	$V(\text{Pin } 8) = 3\text{ V}$	6		6.5	7.0	7.5	V	A
4.6	Maximum control voltage	$V(\text{Pin } 8) = 3\text{ V}$	6			$V_S-1.5$		V	B
4.7	Minimum control voltage	$V(\text{Pin } 8) = 6\text{ V}$	6			0.2	0.7	V	A
4.8	Minimum threshold level	Bits 62, 63 = 0	41		97	99	101	$\text{dB}\mu\text{V}$	A
5	AM Mixer, AM Mode (Bit 92 = 0, Bit 93 = 1)								
5.1	Supply current	Sum of current in Pins 43, 44	43, 44		14	16	20	mA	A
5.2	Conversion conductance		3, 41, 43, 44			4.1		mS	D
5.3	3 rd -order input intercept point	Pin 3 AC-grounded	41	$IP3_{AMmix}$		132		$\text{dB}\mu\text{V}$	C
5.4	Noise figure (SSB)	Generator resistance 2.5 k Ω (Pin 41)	43, 44	NF_{AMmix}		14		dB	C
5.5	Input bias DC voltage		3, 41		2.4	2.6	2.9	V	A
5.6	Input resistance	Single-ended, Pin 39 AC-grounded	3, 41			2.5		k Ω	D
5.7	Input capacitance		3, 41				3	pF	D
5.8	Maximum output voltage	Differential	43, 44		12			V _{pp}	D
5.9	Output resistance		43, 44		100			k Ω	D
6	FM Mixer (FM Mode (Bit 92 = 1, Bit 93 = 0))								
6.1	Supply current	Sum of current in Pins 43, 44	43, 44		15	17.5	20	mA	A
6.2	Conversion conductance		1, 2, 43, 44			7		mS	D

*) Type means: A = 100% tested, B = 100% correlation tested, C = Characterized on samples, D = Design parameter

Electrical Characteristics (Continued)

Test conditions (unless otherwise specified): $V_S = 8.5\text{ V}$, $T_{\text{amb}} = 25^\circ\text{C}$.

No.	Parameters	Test Conditions	Pin	Symbol	Min.	Typ.	Max.	Unit	Type*
6.3	3 rd -order intercept point		1, 2	$IP3_{\text{FMmix}}$		120		dB μ V	C
6.4	Noise figure (DSB)	Generator resistance 200 Ω	43, 44	NF_{FMmix}		10		dB	C
6.5	Input resistance		1, 2			1.6		k Ω	D
6.6	Input capacitance	Pin 2 AC-grounded	1			5		pF	D
6.7	Maximum differential output vltage	$V_S = 8.5\text{ V}$	43, 44		12			V _{pp}	D
6.8	Output resistance		43, 44		100			k Ω	D
7	1st IF FM Amplifier, FM Mode (Bit 92 = 1, Bit 93 = 0)								
7.1	Minimum voltage gain	Bits 89, 90, 91 = 0	38, 30		19	21	23	dB	A
7.2	Temperature coefficient of gain	Bit 66 = 0		TK_{min}		0.039		dB/K	D
7.3	Temperature coefficient of gain	Bit 66 = 1		TK_{max}		0.044		dB/K	D
7.4	Input resistance	Pin 39 AC-grounded	38		270	330	400	Ω	D
7.5	Input capacitance	Pin 39 AC-grounded	38			5		pF	D
7.6	Output resistance		30		270	330	400	Ω	D
8	1st IF AM Amplifier, AM Mode (Bit 92 = 0, Bit 93 = 1)								
8.1	Maximum voltage gain	330 Ω load at Pin 30	30, 33			16		dB	D
8.2	Gain control range					26		dB	D
8.3	Noise figure	Generator resistance 2.5 k Ω		NF_{IFAM}		20		dB	C
8.4	Input resistance		33		10			k Ω	D
8.5	Input capacitance	Pin 39 AC-grounded	33			1		pF	D
8.6	Output resistance		30		270	330	400	Ω	D
9	2nd Mixer								
9.1	FM supply current	Bit 92 = 1, Bit 93 = 0	23, 24		10	14	16	mA	A
9.2	AM/WB supply current	Bit 92 = 0, Bit 93 = 1	23, 24		8	10	12	mA	D
9.3	Conversion conductance		26, 23, 24			2		mS	D
9.4	Noise figure (SSB)	Generator resistance 330 Ω (Pin 26)	23, 24	NF_{Mix2}		23		dB	C
9.5	3 rd -order input intercept point		26	$IP3_{\text{Mix2}}$		132		dB μ V	C
9.6	AM/WB output resistance	Bit 92 = 0, Bit 93 = 1	23, 24		100			k Ω	D
9.7	Maximum differential output voltage AM/WB	$V_S = 8.5\text{ V}$	23, 24		12			V _{pp}	D

*) Type means: A = 100% tested, B = 100% correlation tested, C = Characterized on samples, D = Design parameter

Electrical Characteristics (Continued)

Test conditions (unless otherwise specified): $V_S = 8.5\text{ V}$, $T_{\text{amb}} = 25^\circ\text{C}$.

No.	Parameters	Test Conditions	Pin	Symbol	Min.	Typ.	Max.	Unit	Type*
9.8	Maximum differential output voltage FM		23, 24		1			Vpp	D
9.9	Input resistance		26		270	330	400	Ω	D
9.10	LO input voltage		22		80		500	mVpp	D
9.11	LO input resistance		22			1		k Ω	D
9.12	LO input bias voltage		22		2.8	3.0	3.2	V	A
10	2nd IF Amplifier (Bit 55 = 0)								
10.1	Input resistance	Pin 27 AC-grounded	28			3		k Ω	D
10.2	Maximum voltage gain	AM/WB mode (Bit 93 = 1)	28, 20		44	47	50	dB	A
10.3	Gain control range	AM/WB mode (Bit 93 = 1)				44		dB	D
10.4	Maximum voltage gain	FM mode (Bit 92 = 1, Bit 93 = 0, Bit 54 = 0)	23, 24 20			37		dB	D
10.5	DC output voltage		20		3.1	3.4	3.7	V	A
10.6	AC output voltage	Unmodulated signal, 82 dB μ V at Pin 1 (IF AGC active)	20		145	175	200	mVrms	A
10.7	Output impedance	Small signal	20			70		Ω	D
11	FM Demodulator Integrated Bandfilter, FM Mode (Bit 92 = 1, Bit 93 = 0), BW Setting 2nd IF Filter = 120 kHz								
11.1	AC output voltage	Deviation = $\pm 75\text{ kHz}$, $f_{\text{mod}} = 1\text{ kHz}$	11		420	480	540	mVrms	A
11.2	Stereo roll-off	Deviation = $\pm 75\text{ kHz}$, $f_{\text{mod}} = 38\text{ kHz}$ (reference: 1 kHz)	11		-2.3	-2.0	-1.7	dB	A
11.3	Total harmonic distortion	Deviation = $\pm 75\text{ kHz}$, $f_{\text{mod}} = 1\text{ kHz}$	11	THD_{FM}		0.4	0.7	%	A
11.4	Maximum signal-to-noise ratio	Dev. = $\pm 22.5\text{ kHz}$, $f_{\text{mod}} = 1\text{ kHz}$, 50 μs de-emphasis, signal input at 450 kHz	11	$(\text{S/N})_{\text{FM}}$	62	65		dB	A
12	Soft Mute, FM Mode (Bit 92 = 1, Bit 93 = 0, Bit 80 = 0)								
12.1	Mute gain	Bit 67 = 0, V (Pin 34) = 2 V	11		-31	-28	-26	dB	A
12.2	Mute gain	Bit 67 = 1, V (Pin 34) = 2 V	11		-26	-24	-22	dB	A
12.3	Soft mute threshold	Bits 89-91 = 0, Bits 68-70 = 1	1		50	53	56	dB μ V	B
13	AM Demodulator, AM Mode (Bit 92 = 0, Bit 93 = 1)								
13.1	AC output voltage	Modulation depth = 80%, $f_{\text{mod}} = 1\text{ kHz}$	11		350	400	450	mVrms	A
13.2	Total harmonic distortion	Modulation depth = 80%, $f_{\text{mod}} = 1\text{ kHz}$, V(Pin 35) = const.	11	THD_{AM}		0.6	2	%	A

*) Type means: A = 100% tested, B = 100% correlation tested, C = Characterized on samples, D = Design parameter

Electrical Characteristics (Continued)

Test conditions (unless otherwise specified): $V_S = 8.5\text{ V}$, $T_{\text{amb}} = 25^\circ\text{C}$.

No.	Parameters	Test Conditions	Pin	Symbol	Min.	Typ.	Max.	Unit	Type*
13.3	Maximum signal-to-noise ratio	Modulation depth = 80%, $f_{\text{mod}} = 1\text{ kHz}$, 74 dB μV at Pin 41	11	$(S/N)_{\text{AM}}$	52	54		dB	A
14	MPX Output								
14.1	DC output voltage	Bit 7 = 1	11		2.15	2.25	2.4	V	A
14.2	Mute gain	Bit 7 = 1, FM dev. = $\pm 75\text{ kHz}$, $f_{\text{mod}} = 1\text{ kHz}$	11			-70	-50	dB	A
14.3	Output resistance	Small signal	11			60		Ω	D
15	Search Stop Detector, INT Output								
15.1	LOW saturation voltage		21			0	0.5	V	A
15.2	LOW output resistance		21			0.3		k Ω	D
15.3	HIGH saturation voltage		21		4.5	4.75	5.0	V	A
15.4	HIGH output resistance		21			1		k Ω	D
16	Deviation Sensor, FM Mode (Bit 92 = 1, Bit 93 = 0)								
16.1	Offset voltage	FM dev. = $\pm 0\text{ kHz}$	31			20	150	mV	A
16.2	Output voltage	FM dev. = $\pm 75\text{ kHz}$, $f_{\text{mod}} = 1\text{ kHz}$	31		1.7	2.0	2.5	V	A
17	Field Strength Sensor, FM Mode (Bit 92 = 1, Bit 93 = 0, Bit 89-91 = 0, Bit 80 = 0)								
17.1	Offset voltage	No signal	9		0.4	0.75	1.1	V	A
17.2	Output voltage	Unmodulated signal 84 dB μV at Pin 1	9		2.7	3.0	3.3	V	A
	Field Strength Sensor, AM Mode (Bit 92 = 0, Bit 93 = 1, Bit 80 = 1)								
17.3	Output voltage LOW field strength	63 dB μV at Pin 28	9		0.7	0.9	1.1	V	A
17.4	Output voltage HIGH field strength	94 dB μV at Pin 28	9		2.3	2.5	2.7	V	A
18	Multipath Sensor, FM Mode (Bit 92 = 1, Bit 93 = 0)								
18.1	Offset voltage	Unmodulated signal, 60 dB μV at Pin 1	40			20	200	mV	A
18.2	Output voltage	AM modulation depth = 60%, $f_{\text{mod}} = 20\text{ kHz}$, 60 dB μV at Pin 1	40		1.4	1.8	2.2	V	A
19	Adjacent Channel Sensor, FM Mode (Bit 92 = 1, Bit 93 = 0), Bit 4 = 0 (Default BW Setting)								
19.1	Offset voltage	Unmodulated signal	10			100	300	mV	A
19.2	Output voltage	FM dev. = $\pm 50\text{ kHz}$, $f_{\text{mod}} = 1\text{ kHz}$	10			0.6	1.0	V	A

*) Type means: A = 100% tested, B = 100% correlation tested, C = Characterized on samples, D = Design parameter

Electrical Characteristics (Continued)

Test conditions (unless otherwise specified): $V_S = 8.5\text{ V}$, $T_{amb} = 25^\circ\text{C}$.

No.	Parameters	Test Conditions	Pin	Symbol	Min.	Typ.	Max.	Unit	Type*
19.3	Output voltage	Desired FM dev. = $\pm 75\text{ kHz}$, $f_{mod} = 1\text{ kHz}$ undesired: unmodulated RF level undesired/desired: +30 dB frequency offset = -150 kHz	10		1.0	1.2	1.6	V	A
20	3-wire Bus								
20.1	Input voltage LOW		17, 18, 19				0.8	V	D
20.2	Input voltage HIGH		17, 18, 19		2.7			V	D
20.3	Leakage current	$V = 0\text{ V}, 5\text{ V}$	17, 18, 19				10	μA	D
20.4	Clock frequency		18				1.0	MHz	D
20.5	Period of CLK HIGH LOW			t_H t_L	250 250			ns ns	D
20.6	Rise time EN, DATA, CLK			t_r			400	ns	D
20.7	Fall time EN, DATA, CLK			t_f			100	ns	D
20.8	Set-up time			t_s	100			ns	D
20.9	Hold time EN			t_{HEN}	250			ns	D
20.10	Hold time DATA			t_{HDA}	0			ns	D
21	Internally Generated Reference Voltages								
21.1	Output voltage		12		5.5	5.7	6.0	V	A
21.2	Output voltage		29			3.0		V	D
21.3	Output voltage		27			3.0		V	D
21.4	Output voltage		39			3.0		V	D

*) Type means: A = 100% tested, B = 100% correlation tested, C = Characterized on samples, D = Design parameter

Diagrams

The following data was measured with the application board (see Figure 20).

In the measurement setup, a 50-Ω generator is terminated by 50 Ω and connected to the antenna input by a 50-Ω series resistor to achieve 75-Ω termination at the antenna input. The generator level specified is the output voltage of this 50-Ω generator at 50 Ω load. If the application board is replaced by a 75-Ω resistor, the voltage at this resistor is 6 dB below the specified voltage level of the 50 Ω generator.

Figure 12. FM Demodulator

Integrated bandfilter BW setting: 120 kHz, Bits 0 to 2 = 0, Bit 3 = 1;
1 kHz modulation frequency; 50 μs de-emphasis (THD)

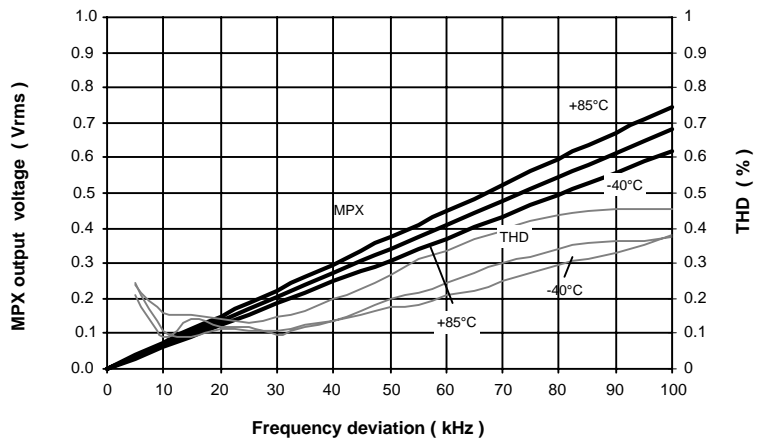

Figure 13. Multipath Sensor

AM modulation frequency 20 kHz; generator level 40 dBμV

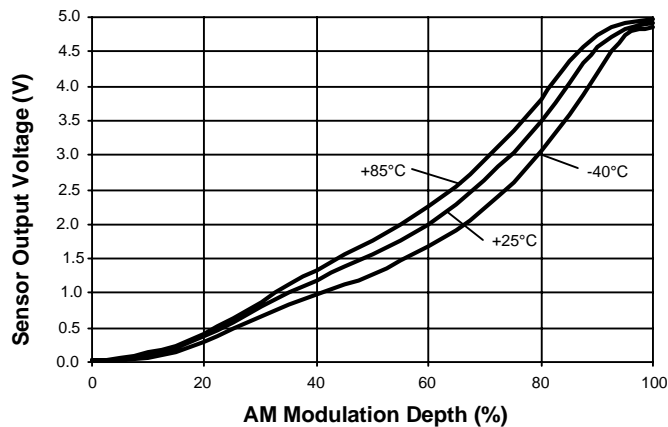

Figure 14. Multipath Sensor Frequency Response

Generator level 40 dB μ V

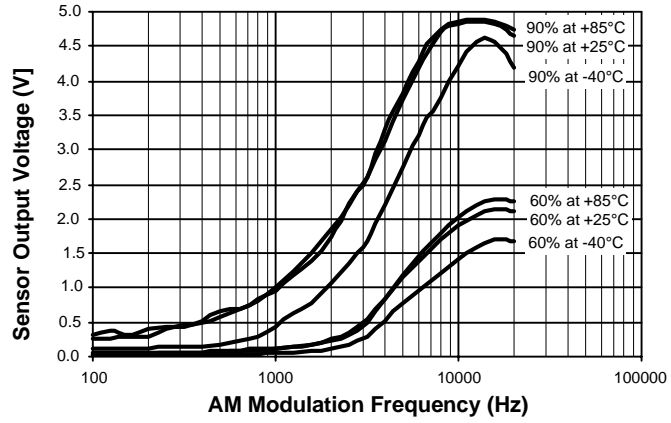

Figure 15. Deviation Sensor

FM modulation frequency: 1 kHz; BW setting 2nd IF filter = 120 kHz

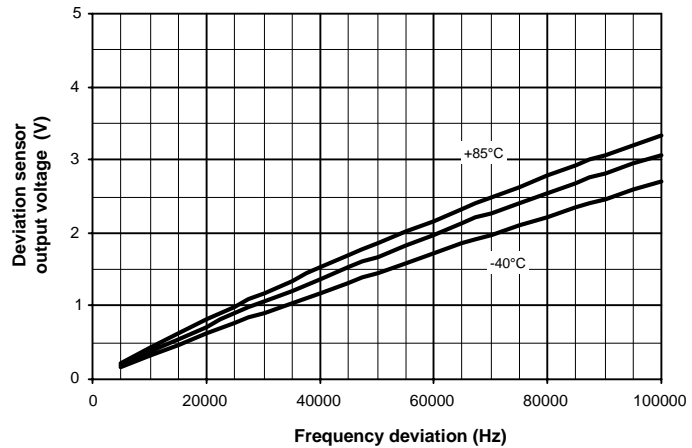

Figure 16. Deviation Sensor Frequency Response

FM frequency deviation: 22.5 kHz

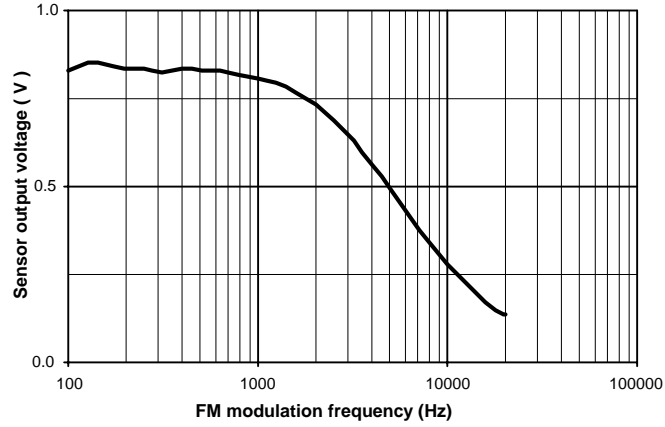

Figure 17. FM Input Level Sweep

Soft mute threshold Bits 68, 69 = 0, Bit 70 = 1; soft mute gain Bit 67 = 1
gain FM IF amplifier Bit 89 = 1, Bits 90, 91 = 0

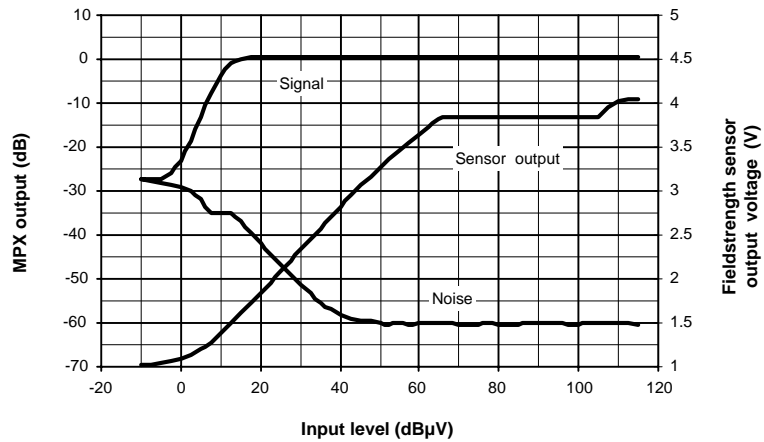

Figure 18. Selectivity

Integrated bandfilter BW setting: 120 kHz
 desired signal level adjusted to 40 dB S/N without undesired signal
 undesired signal level adjusted to 26 dB S/N

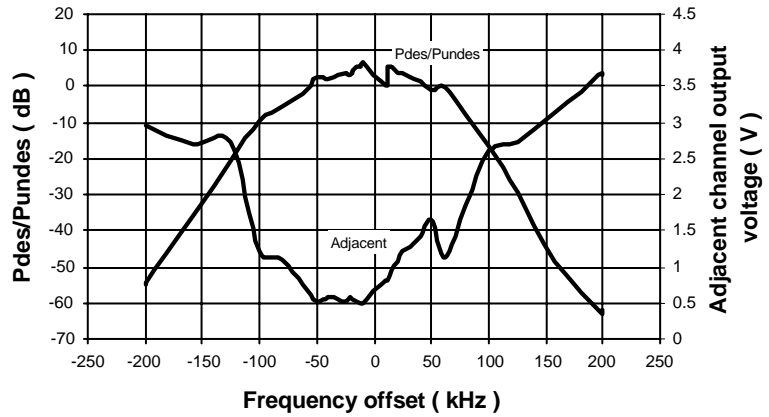
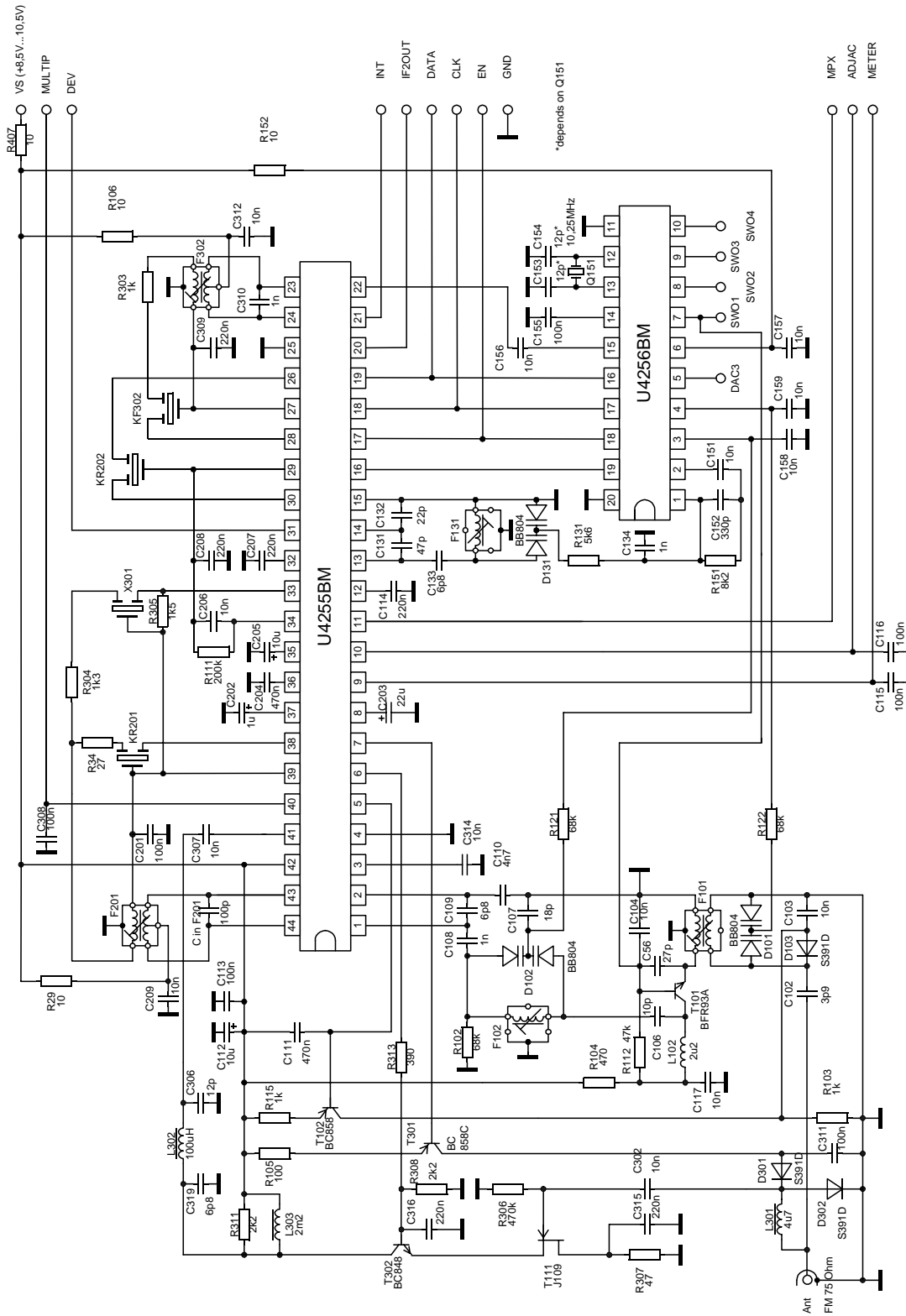

Figure 20. Application Circuit



Ordering Information

Extended Type Number	Package	Remarks
U4255BM-MFN	SSO44	Tube
U4255BM-MFNG3	SSO44	Taped and reeled

Package Information

Package SSO44

Dimensions in mm

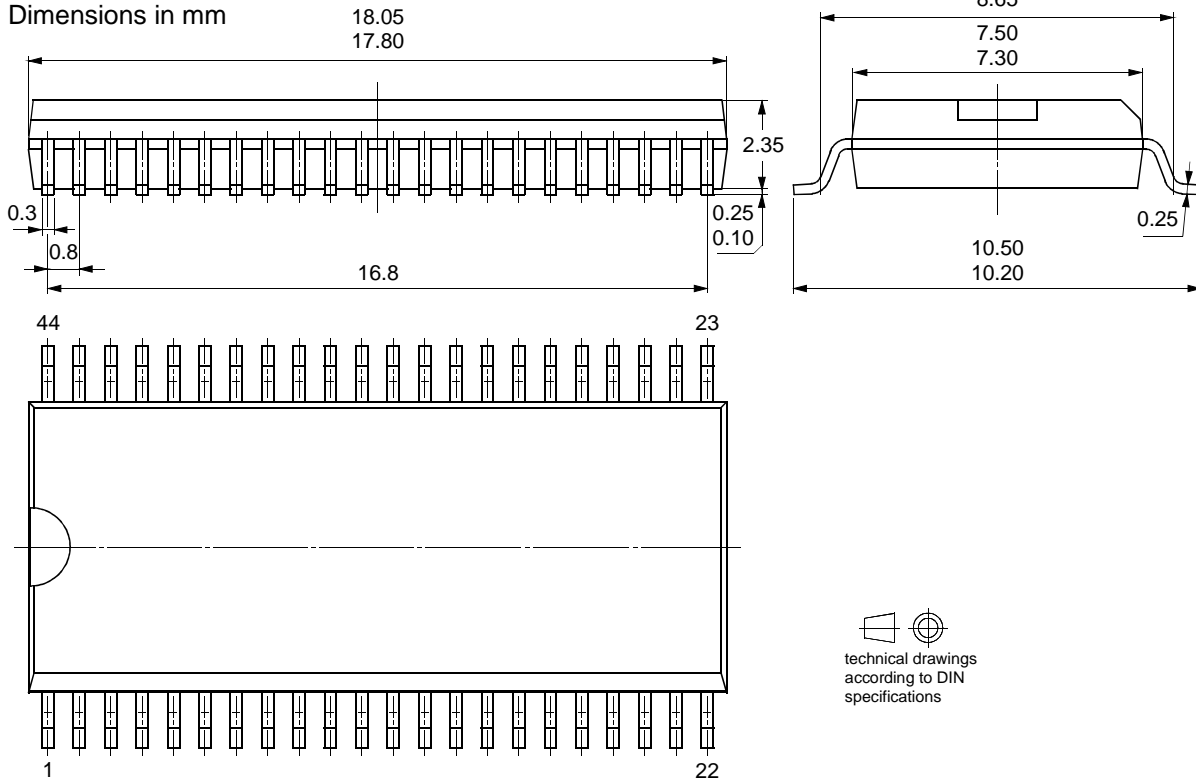

 technical drawings
 according to DIN
 specifications



Atmel Headquarters

Corporate Headquarters
2325 Orchard Parkway
San Jose, CA 95131
TEL 1(408) 441-0311
FAX 1(408) 487-2600

Europe

Atmel Sarl
Route des Arsenaux 41
Case Postale 80
CH-1705 Fribourg
Switzerland
TEL (41) 26-426-5555
FAX (41) 26-426-5500

Asia

Room 1219
Chinachem Golden Plaza
77 Mody Road Tsimhatsui
East Kowloon
Hong Kong
TEL (852) 2721-9778
FAX (852) 2722-1369

Japan

9F, Tonetsu Shinkawa Bldg.
1-24-8 Shinkawa
Chuo-ku, Tokyo 104-0033
Japan
TEL (81) 3-3523-3551
FAX (81) 3-3523-7581

Atmel Operations

Memory

2325 Orchard Parkway
San Jose, CA 95131
TEL 1(408) 441-0311
FAX 1(408) 436-4314

Microcontrollers

2325 Orchard Parkway
San Jose, CA 95131
TEL 1(408) 441-0311
FAX 1(408) 436-4314

La Chantrerie
BP 70602
44306 Nantes Cedex 3, France
TEL (33) 2-40-18-18-18
FAX (33) 2-40-18-19-60

ASIC/ASSP/Smart Cards

Zone Industrielle
13106 Rousset Cedex, France
TEL (33) 4-42-53-60-00
FAX (33) 4-42-53-60-01

1150 East Cheyenne Mtn. Blvd.
Colorado Springs, CO 80906
TEL 1(719) 576-3300
FAX 1(719) 540-1759

Scottish Enterprise Technology Park
Maxwell Building
East Kilbride G75 0QR, Scotland
TEL (44) 1355-803-000
FAX (44) 1355-242-743

RF/Automotive

Theresienstrasse 2
Postfach 3535
74025 Heilbronn, Germany
TEL (49) 71-31-67-0
FAX (49) 71-31-67-2340

1150 East Cheyenne Mtn. Blvd.
Colorado Springs, CO 80906
TEL 1(719) 576-3300
FAX 1(719) 540-1759

Biometrics/Imaging/Hi-Rel MPU/ High Speed Converters/RF Datacom

Avenue de Rochepleine
BP 123
38521 Saint-Egreve Cedex, France
TEL (33) 4-76-58-30-00
FAX (33) 4-76-58-34-80

e-mail

literature@atmel.com

Web Site

<http://www.atmel.com>

© Atmel Corporation 2002.

Atmel Corporation makes no warranty for the use of its products, other than those expressly contained in the Company's standard warranty which is detailed in Atmel's Terms and Conditions located on the Company's web site. The Company assumes no responsibility for any errors which may appear in this document, reserves the right to change devices or specifications detailed herein at any time without notice, and does not make any commitment to update the information contained herein. No licenses to patents or other intellectual property of Atmel are granted by the Company in connection with the sale of Atmel products, expressly or by implication. Atmel's products are not authorized for use as critical components in life support devices or systems.

Atmel® is the registered trademark of Atmel.

Other terms and product names may be the trademarks of others.



Printed on recycled paper.