

Reversible motor driver

BA6283N / BA6284N / BA6955N

The BA6283N, BA6284N, and BA6955N are reversible-motor drivers with a maximum output current of 1.0 A. Two logic inputs allow four output modes: forward, reverse, stop (standby), and brake. The built-in power save circuit suppresses current consumption in the motor stop mode.

●Applications

VCRs, audio devices

●Features

- 1) Logic and driver sections have separate ground pins; this allows the IC to drive speed-variable, reversible motors by connecting an electronic governor circuit.
- 2) Built-in power saving circuit suppresses current consumption in stop (standby) mode.
- 3) Interfaces with TTL devices.
- 4) Built-in thermal shutdown circuit.

●Absolute maximum ratings (Ta = 25°C)

Parameter	Symbol	Limits	Unit
Applied voltage	V _{CC}	18	V
Power dissipation	BA6283N	1150*1	mW
	BA6284N	1150*1	
	BA6955N	1080*2	
Operating temperature	T _{opr}	-20~+75	°C
Storage temperature	T _{stg}	-55~+150	°C
Output current	I _{OUT}	1000*3	mA

*1 Reduced by 9.2mW for each increase in Ta of 1°C over 25°C.

*2 Reduced by 8.64mW for each increase in Ta of 1°C over 25°C.

*3 Should not exceed Pd or ASO values.

●Recommended operating conditions (Ta = 25°C)

Parameter	Symbol	Min.	Typ.	Max.	Unit
Operating power supply voltage	V _{CC}	5.5	—	15	V
	V _M	5.5	—	15	V

●Block diagram

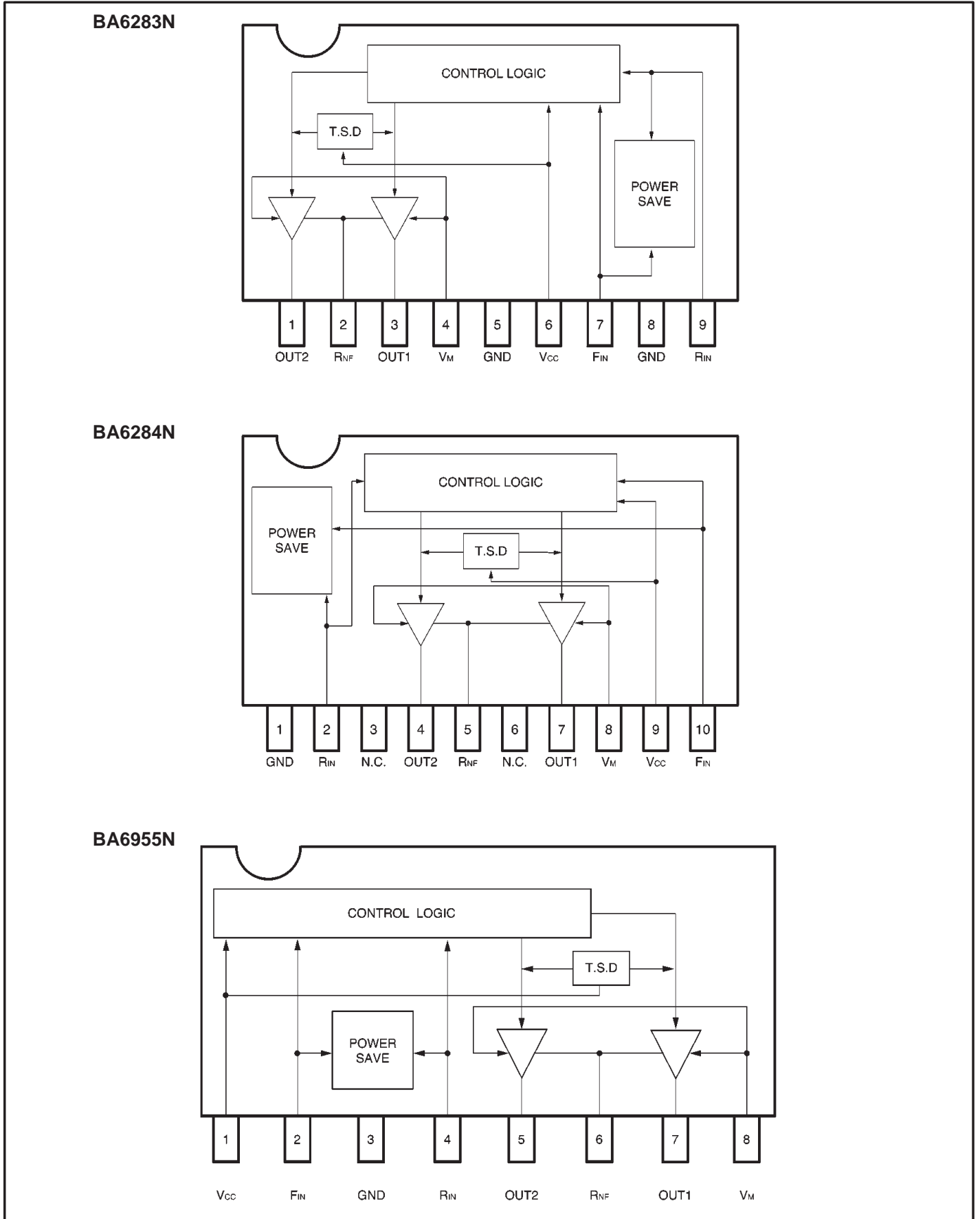

●Pin descriptions

BA6283N

Pin No.	Pin name	Function
1	OUT2	Motor output
2	R _{NF}	Output GND, for connecting resistor for output current detection
3	OUT1	Motor output
4	V _M	Motor power supply
5	GND	GND
6	V _{CC}	Power supply
7	F _{IN}	Logic input
8	GND	GND
9	R _{IN}	Logic input

BA6284N

Pin No.	Pin name	Function
1	GND	GND
2	R _{IN}	Logic input
3	N.C.	—
4	OUT2	Motor output
5	R _{NF}	Output GND, for connecting resistor for output current detection
6	N.C.	—
7	OUT1	Motor output
8	V _M	Motor power supply
9	V _{CC}	Power supply
10	F _{IN}	Logic input

BA6955N

Pin No.	Pin name	Function
1	V _{CC}	Power supply
2	F _{IN}	Logic input
3	GND	GND
4	R _{IN}	Logic input
5	OUT2	Motor output
6	R _{NF}	Output GND, for connecting resistor for output current detection
7	OUT1	Motor output
8	V _M	Motor power supply

●Electrical characteristics (unless otherwise noted, $T_a = 25^\circ\text{C}$, $V_{CC} = 9\text{V}$, and $V_M = 9\text{V}$)

Parameter	Symbol	Min.	Typ.	Max.	Unit	Conditions
Circuit current 1	I_{CC1}	—	30	43.5	mA	Forward or reverse mode
Circuit current 2	I_{CC2}	—	40	58	mA	Brake mode
Circuit current 3	I_{CC3}	—	—	15	μA	Standby mode
Input high level voltage	V_{IH}	2.0	—	—	V	—
Input low level voltage	V_{IL}	—	—	0.8	V	—
Input high level current	I_{IH}	50	90	130	μA	$V_{IN}=2.0\text{V}$
Output saturation voltage	V_{CE}	—	1.0	1.5	V	$I_O=200\text{mA}$ Sum of the high and low side output transistor voltages

◎Not designed for radiation resistance.

●Input / output truth table

F_{IN}	R_{IN}	OUT 1	OUT 2	Mode
H	L	H	L	Forward
L	H	L	H	Reverse
H	H	L	L	Brake
L	L	OPEN	OPEN	Standby

●Application example

BA6283N

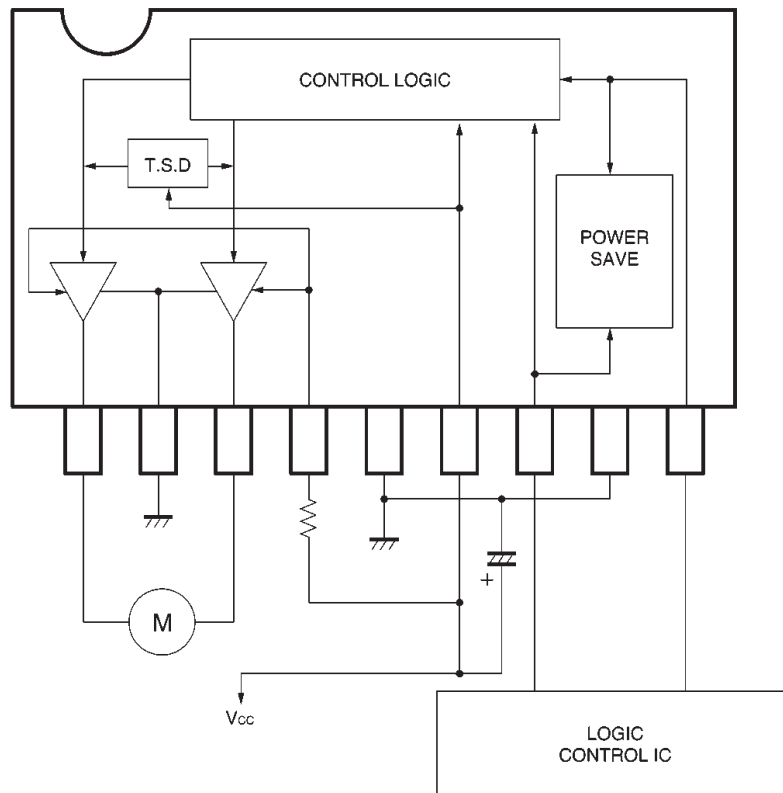

Fig.3

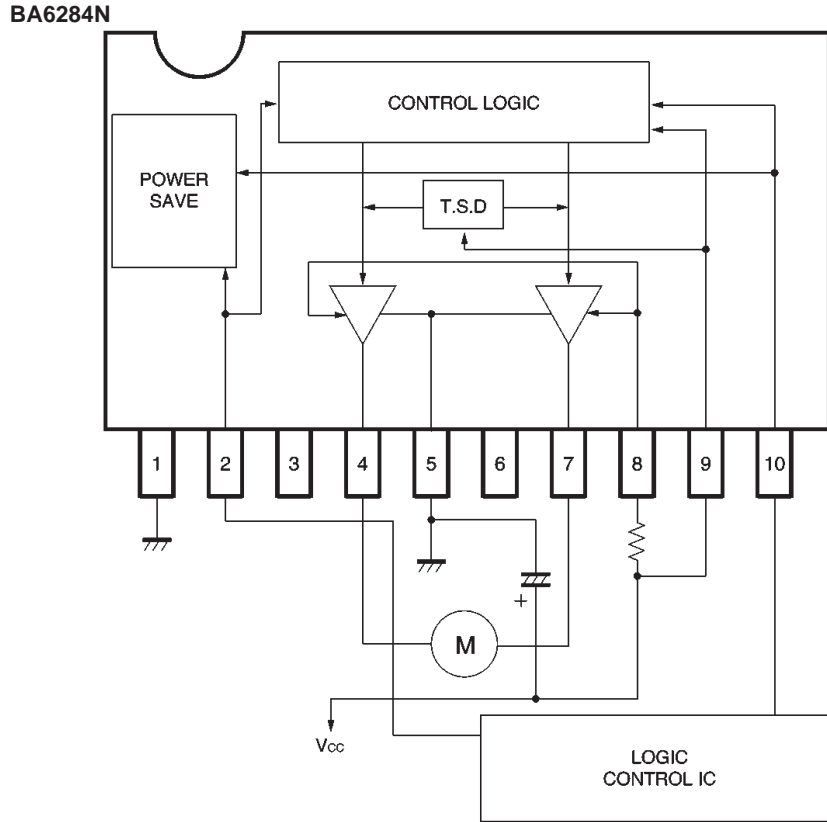

Fig.4

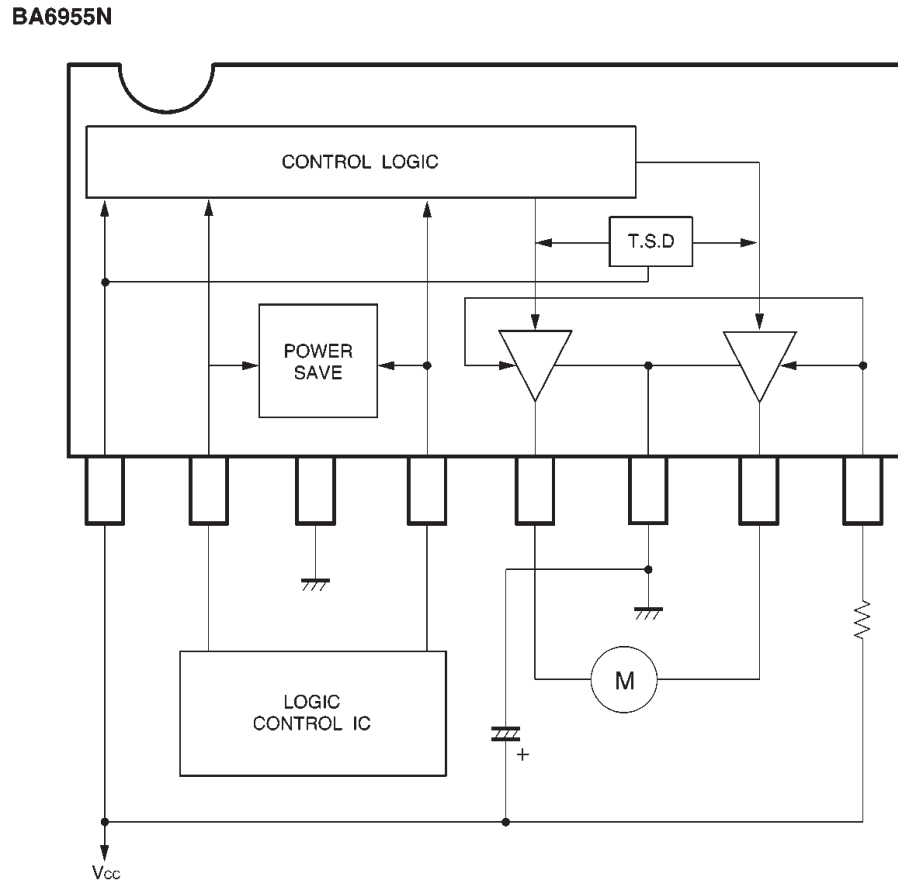

Fig.5

● Operation notes

(1) The quality of these products have been carefully checked; however, use of the products with applied voltages, operating temperatures, or other parameters that exceed the absolute maximum rating given may result in the damage of the IC and the product it is used in. If the IC is damaged, the short mode and open modes cannot be specified, so if the IC is to be used in applications where parameters may exceed the absolute maximum ratings, then be sure to incorporate fuses, or other physical safety measures.

(2) GND potential

The potential for pin 1 must be kept lower than the potentials of the other pins regardless of the circumstances.

(3) Input pins

Voltage should never be applied to the input pins when the V_{CC} voltage is not applied to the IC. Similarly, when V_{CC} is applied, the voltage on each input pin should be less than V_{CC} and within the guaranteed range for the electrical characteristics.

(4) Back-rush voltage

Depending on the ambient conditions, environment, or motor characteristics, the back-rush voltage may fluctuate. Be sure to confirm that the back-rush voltage will not adversely affect the operation of the IC.

(5) Large current line

Large currents are carried by the motor power supply and motor ground for these ICs. Therefore, the layout of the pattern of the PC board and the constants of certain parameters for external components, such as the capacitor between the power supply and ground, may cause this large output current to flow back to the input pins, resulting in output oscillation or other malfunctions. To prevent this, make sure that the PC board layout and external circuit constants cause no problems with the characteristics of these ICs.

(6) Power dissipation

The power dissipation will fluctuate depending on the mounting conditions of the IC and the ambient environment. Make sure to carefully check the thermal design of the application where these ICs will be used.

(7) Power consumption

The power consumption by the IC varies widely with the power supply voltage and the output current. Give full consideration to the power dissipation rating and the thermal resistance data and transient thermal resistance data, to provide a thermal design so that none of the ratings for the IC are exceeded.

(8) ASO

Make sure that the output current and supply voltage do not exceed the ASO values.

(9) Precautions for input mode switching

To ensure reliability, it is recommended that the mode switching for the motor pass once through the open mode.

(10) Rush current

There are no circuits built into these ICs that prevent rush currents. Therefore, it is recommended to place a current limiting resistor or other physical countermeasure.

(11) Factors regarding the thermal, power supply, and motor conditions. If the potential of the output pin sways greatly and goes below the potential of ground, the operation of the IC may malfunction or be adversely affected. In such a case, place a diode between the output and ground, or other measure, to prevent this.

(12) Input pins (F_{IN} and R_{IN}) thermal characteristics

The F_{IN} and R_{IN} pins have thermal characteristics. Take these thermal characteristics into consideration when using the IC.

(13) Thermal shutdown circuit (TSD)

When the junction temperature reaches approximately 170°C (Typ.) during operation, the driver outputs are all turned off.

There is an approximate 20°C (Typ.) thermal hysteresis.

(14) Motor noise

To eliminate motor noise, connect a capacitor between OUT1 and GND and between OUT2 and GND. Alternatively, connect a capacitor between OUT1 and OUT2, and also a diode between OUT1 and GND and between OUT2 and GND (see the figure below).

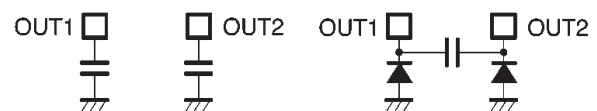

●Electrical characteristic curves

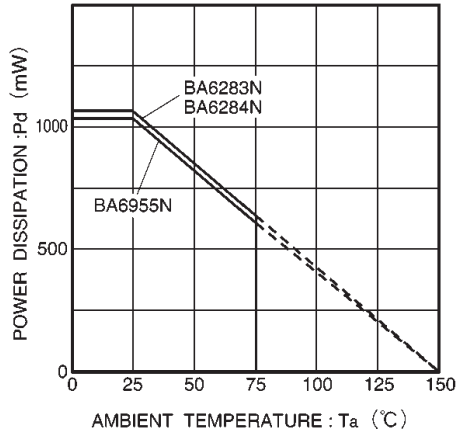

Fig.6 Package thermal derating characteristics

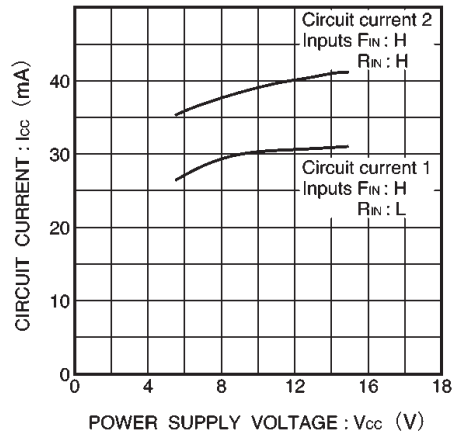

Fig.7 Circuit current vs. power supply voltage

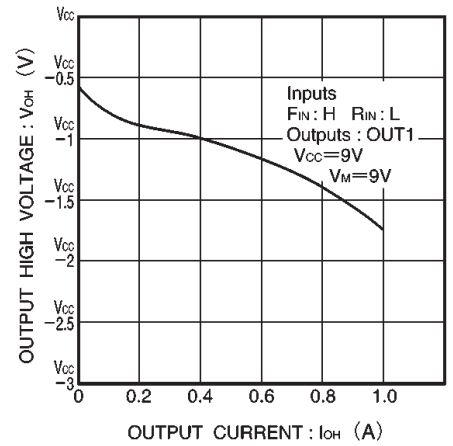

Fig.8 Output high level voltage vs. output current

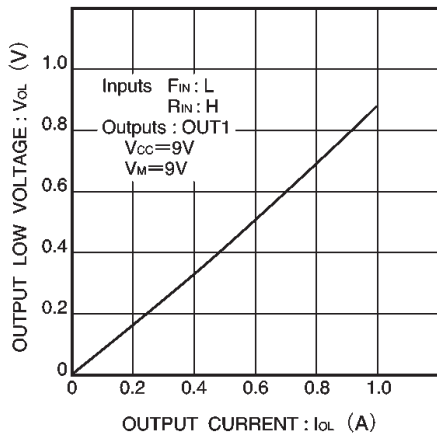

Fig.9 Output low level voltage vs. output current

● External dimensions (Units: mm)

