

# LED level meter driver, 5-point, VU scale

## BA6137

The BA6137 is a driver IC for LED VU level meters in stereo equipment and other display applications. The IC displays the input level (range:  $-10\text{dB}$  to  $+6\text{dB}$ ) on a 5-point, bar-type LED display. .  
The BA6137 includes a rectifier amplifier allowing direct AC input, and has constant-current outputs, so it can directly drive the LEDs without variations in LED current due to supply voltage fluctuations.

### ● Applications

VU meters, signal meters, and other display devices.

### ● Features

- 1) Rectifier amplifier allows either AC or DC input.
- 2) Constant-current outputs for constant LED current when the supply voltage fluctuates.
- 3) Current output is optimized for red LEDs, for low power consumption.
- 4) Built-in reference voltage means that power supply voltage fluctuations do not effect the display.
- 5) Wide operating voltage range (3.5V to 16V) for a wide range of applications.
- 6) Low PCB space requirements. Comes in a compact 9-pin SIP package and requires few external components.

### ● Block diagram

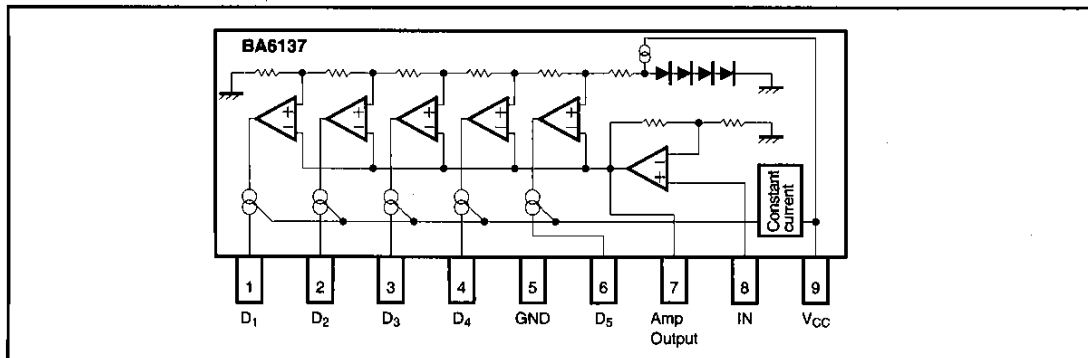

### ● Absolute maximum ratings (Ta = 25°C)

Parameter	Symbol	Limits	Unit
Supply voltage	V <sub>CC</sub>	18	V
Power dissipation	P <sub>d</sub>	800*	mW
Operating temperature	T <sub>opr</sub>	-25~60	°C
Storage temperature	T <sub>stg</sub>	-55~125	°C
Junction temperature	T <sub>J</sub>	150	°C

\* Reduced by 6.4mW for each increase in Ta of 1°C over 25°C.

●Electrical characteristics (unless otherwise specified  $T_a = 25^\circ\text{C}$ ,  $V_{CC} = 6.0\text{V}$ , and  $f = 1\text{kHz}$ )

Parameter	Symbol	Min.	Typ.	Max.	Unit	Conditions	Measurement Circuit
Supply voltage	$V_{CC}$	3.5	6	16	V	—	Fig.1
Quiescent current	$I_Q$	—	5	8	mA	$V_{IN}=0\text{V}$	Fig.1
Control level 1	$V_{C1}$	-11.5	-10	-8.5	dB	—	Fig.1
Control level 2	$V_{C2}$	-6	-5	-4	dB	—	Fig.1
Control level 3	$V_{C3}$	—	0	—	dB	Adjustment point	Fig.1
Control level 4	$V_{C4}$	2.5	3	3.5	dB	—	Fig.1
Control level 5	$V_{C5}$	5	6	7	dB	—	Fig.1
Sensitivity	$V_{IN}$	74	85	96	$\text{mV}_{\text{rms}}$	$V_{C3}$ on level	Fig.1
LED current	$I_{LED}$	5	7	9.5	mA	—	Fig.1
Input bias current	$I_{INO}$	—	0.3	1.0	$\mu\text{A}$	—	Fig.1

●Measurement circuit

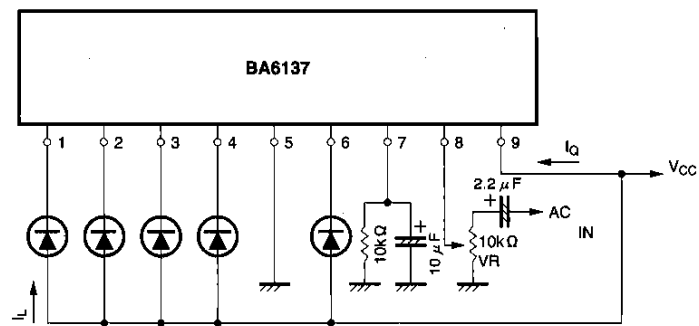

Fig. 1

●Application example

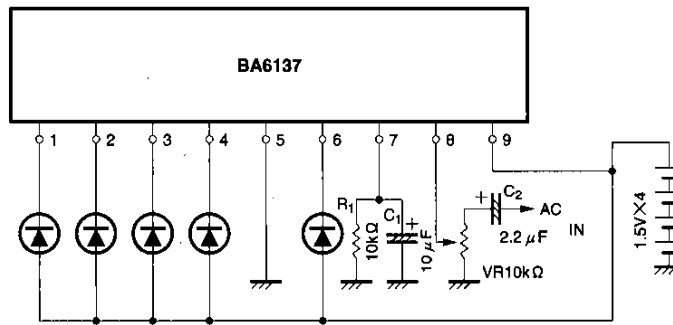

Fig. 2

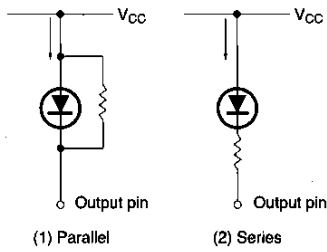

Fig. 3

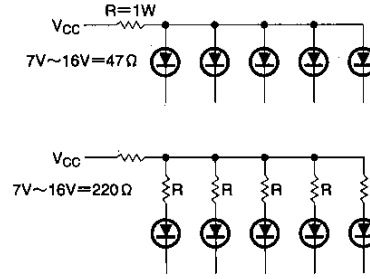

Fig. 4

The response time (attack and release time) can be changed by varying the values of  $C_1$  and  $C_2$  to change the time constant.

$C_2$  is a coupling capacitor, and VR varies the input level. Input the desired fixed voltage and adjust VR so that the LED lights at 0dB.

To reduce the LED current, connect a resistor either in parallel (Fig. 3 (1)) or in series (Fig. 3 (2)) with the LED.

If a resistor is connected in series with the LED, the LED current will change if the supply voltage fluctuates.

Note: If the power supply voltage exceeds 9V, insert a resistor in series with the LED current supply line, or connect a heat sink so that the maximum power dissipation  $P_{d\text{max}}$  is not exceeded (see Fig. 4).

●External dimensions (Unit: mm)

