

FM IF/AM TUNER SYSTEM

The KA22471 is a monolithic integrated circuit developed for the radio cassette tape recorder.

FUNCTIONS

- AM SECTION: Converter, IF amplifier, Detector, Tuning indicator.
- FM SECTION: IF amplifier, Quadrature detector, Tuning indicator.

FEATURES

- Low quiescent circuit current.
AM: 7mA (Typ) FM: 10mA (Typ)
- A minimum number of external parts required.
- Built-in AM/FM function switch.
- Tuning indicator: direct LED driving capability: $I_{LAMP} = 10\text{mA (MAX)}$
- One terminal AM/FM detector output.
- Advanced performance at high input signal.
- Operating supply voltage range: $V_{CC} = 3\text{V} \sim 8\text{V}$.

16 DIP

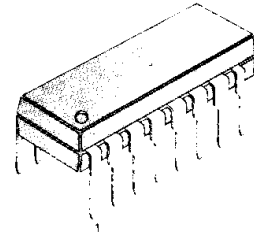

ORDERING INFORMATION

Device	Package	Operating Temperature
KA22471	16 DIP	-20°C ~ +70°C

BLOCK DIAGRAM

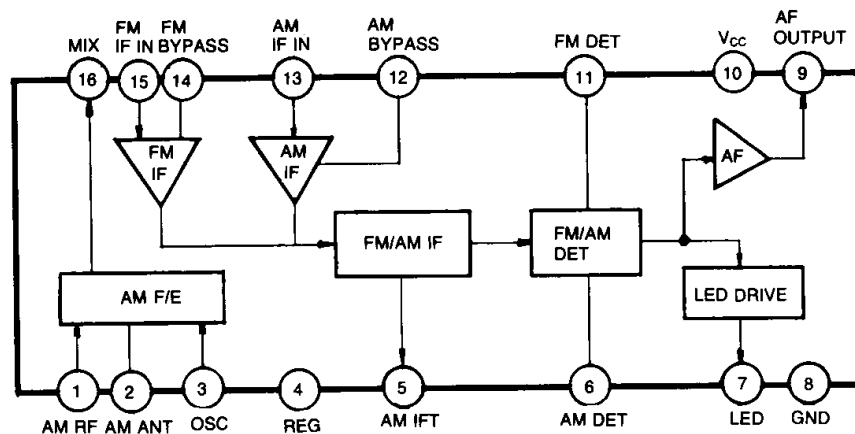

Fig. 1

ABSOLUTE MAXIMUM RATINGS ($T_a = 25^\circ\text{C}$)

Characteristic	Symbol	Value	Unit
Supply Voltage	V_{CC}	8	V
Power Dissipation	P_D	600	mW
Operating Temperature	T_{OPR}	-20 ~ +70	$^\circ\text{C}$
Storage Temperature	T_{STG}	-40 ~ +125	$^\circ\text{C}$

ELECTRICAL CHARACTERISTICS

($T_a = 25^\circ\text{C}$, $V_{CC} = 5\text{V}$, unless otherwise specified)

FM Section ($f = 10.7\text{MHz}$, $f_m = 400\text{Hz}$, $\Delta f = \pm 22.5\text{KHz}$)

Characteristic	Symbol	Test Conditions	Min	Typ	Max	Unit
Quiescent Circuit Current	I_{CCQ}	$V_i = 0$		10	15	mA
-3dB Limiting Sensitivity	$V_{i(LIM)}$	$V_o (V_i = 80\text{dB}\mu)$ -3dB down		40	46	$\text{dB}\mu$
Detector Output Voltage	$V_{O(DET)}$	$V_i = 66\text{dB}\mu$, $R_{DUMP} = 4.7\text{K}\Omega$	57	85	114	mV
Total Harmonic Distortion	THD	$V_i = 80\text{dB}\mu$		0.05		%
AM Rejection Ratio	AMR	$V_i = 80\text{dB}\mu$, AM: $f_m = 1\text{KHz}$, 30% Mod		38		dB
Signal to Noise Ratio	S/N	$V_i = 80\text{dB}\mu$		65		dB
Signal Meter Output	V_M	$V_i = 100\text{dB}\mu$	1.55	1.7	1.85	V
Tuning Indication Voltage	V_L	$I_{LAMP} = 1\text{mA}$		46	52	$\text{dB}\mu$

AM Section ($f = 1\text{MHz}$, 30% Mod, $f_m = 400\text{Hz}$)

Characteristic	Symbol	Test Conditions	Min	Typ	Max	Unit
Quiescent Circuit Current	I_{CCQ}	$V_i = 0$		7	10	mA
Voltage Gain	G_V	$V_i = 26\text{dB}\mu$	20	30	60	mV
Detector Output Voltage	$V_{O(DET)}$	$V_i = 60\text{dB}\mu$	65	95	125	mV
Total Harmonic Distortion	THD	$V_i = 60\text{dB}\mu$		1.0		%
Signal to Noise Ratio	S/N	$V_i = 60\text{dB}\mu$		47		dB
Signal Meter Output	V_M	$V_i = 100\text{dB}\mu$	1.55	1.7	1.85	V
Tuning Indication Voltage	V_L	$I_{LAMP} = 1\text{mA}$		32		$\text{dB}\mu$
Oscillator Stop Voltage	V_{STOP}	$R_{DUMP} = \infty$		1.5		V

TEST CIRCUIT

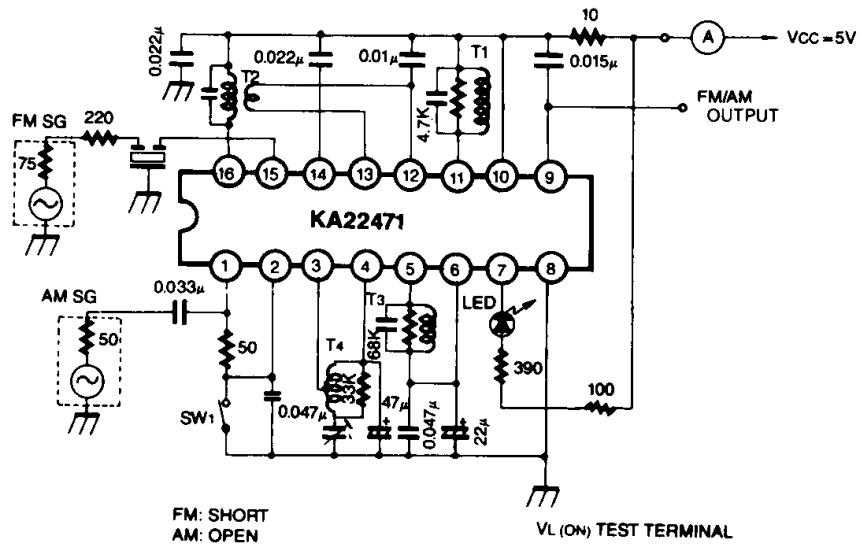
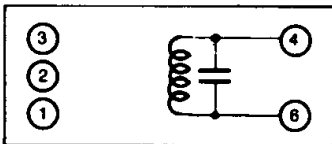

Fig. 2

COIL SPECIFICATIONS

T1 FM IF (DET)



C _o (pF)	f (MHz)	Q _o	TURNES
4-6		4-6	4-6
47	10.7	150	14

Seoul Jupa
0.12mmφ UEW

T2 AM IFT (MIX OUT)

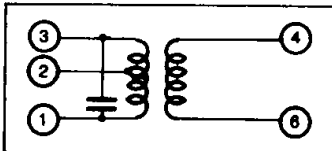

C _o (PF)	f (KHz)	Q _o	TURNES		
1-3		1-3	1-2	2-3	4-6
180	455	110	90	62	8

Seoul Jupa
0.07mmφ UEW

T3 AM IFT (DET)

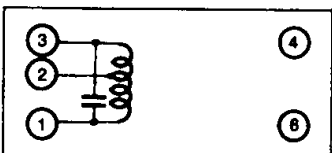

C _o (pF)	f (KHz)	Q _o	TURNES
1-3		1-3	1-3
180	455	110	152

Seoul Jupa
0.07mmφ UEW

T4 (MW OSC)

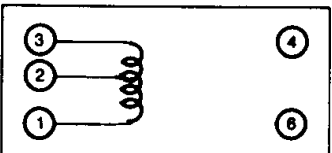

f (KHz)	L (μH)	Q _o	TURNES	
	1-3	1-3	1-2	2-3
796	288	120	13	75

Seoul Jupa
0.06mmφ UEW

APPLICATION CIRCUIT

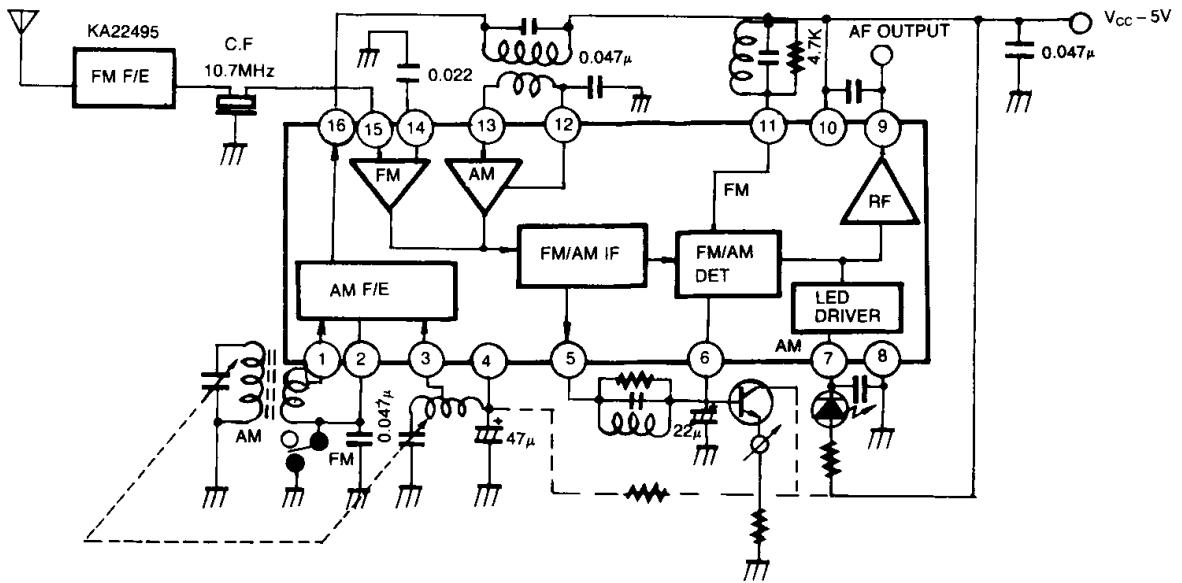

Fig. 3

3