

**AM/FM IF SYSTEM**

The KA2243 is a monolithic integrated circuit developed for radio cassette tape recorders which include AM/FM IF amplifier and detector.

**FUNCTIONS**

- AM Section:
  - IF amplifier with AGC detector.
  - Signal meter driver circuit.
  - Voltage regulator for RF external circuit.
- FM Section:
  - IF amplifier.
  - Quadrature detector.
  - Post amplifier.
  - Signal meter driver circuit.

**FEATURES**

- Suitable for radio cassettes and home stereos.
- Wide operating supply voltage range:  $V_{CC} = 3V \sim 14V$ .
- Low quiescent circuit current .
- AM section.
  - Simplified input circuit IFT (Ceramic filter type).
  - RF AGC available.
- FM section.
  - High limiting sensitivity ( $33dB\mu$ , Typ).
  - Low residual noise ( $45dB$  at  $V_1 = -10dB\mu$ ).
  - Small side peak or detuned output voltage.

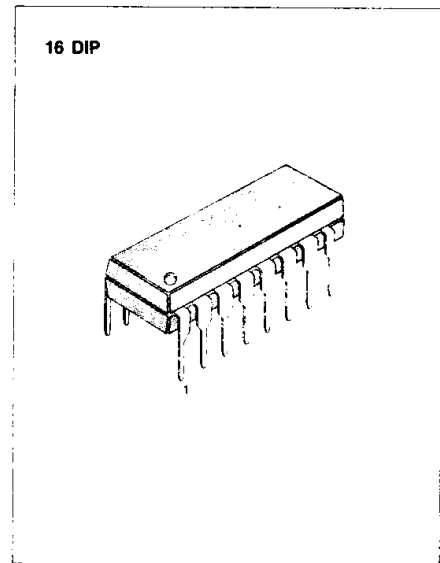

**ORDERING INFORMATION**

Device	Package	Operating Temperature
KA2243	16 DIP	- 20°C ~ + 70°C

**BLOCK DIAGRAM**

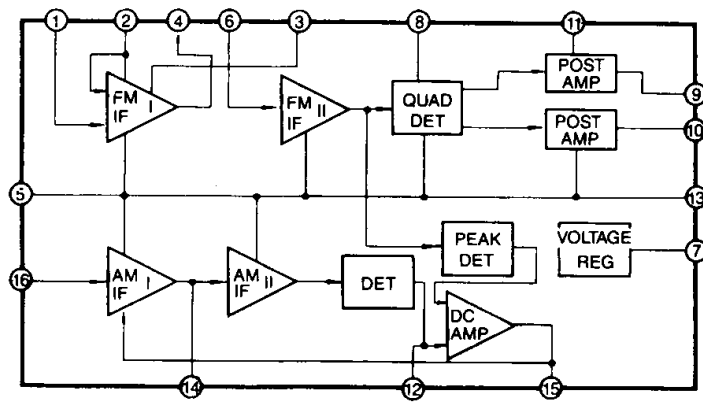

ABSOLUTE MAXIMUM RATINGS ( $T_a = 25^\circ\text{C}$ )

Characteristic	Symbol	Value	Unit
Supply Voltage	$V_{CC}$	16	V
Power Dissipation	$P_D$	600	mW
Operating Temperature	$T_{OPR}$	-20 ~ +70	$^\circ\text{C}$
Storage Temperature	$T_{STG}$	-40 ~ +125	$^\circ\text{C}$

## ELECTRICAL CHARACTERISTICS

( $T_a = 25^\circ\text{C}$ ,  $V_{CC} = 5.5\text{V}$ , unless otherwise specified)

Characteristic	Symbol	Test Conditions	Min	Typ	Max	Unit
----------------	--------	-----------------	-----	-----	-----	------

FM Section ( $f = 10.7\text{MHz}$ ,  $f_m = 1\text{KHz}$ ,  $\Delta f = \pm 75\text{KHz}$ )

Quiescent Circuit Current	$I_{CCQ}$	$V_i = 0$	7	11	16.5	mA
-3dB Limiting Sensitivity	$V_{i(LIM)}$	$V_o (V_i = 100\text{dB}\mu) - 3\text{dB}$		33	38	$\text{dB}\mu$
Detector Output Voltage	$V_{O(DET)}$	$V_i = 100\text{dB}\mu$	180	245	310	mV
Total Harmonic Distortion	THD	$V_i = 100\text{dB}\mu$		0.3	1.0	%
AM Rejection Ratio	AMR	$V_i = 100\text{dB}\mu$	50	60		dB
Signal to Noise Ratio	S/N	$V_i = 100\text{dB}\mu$	72	83		dB
Signal Meter Output	$V_M$	$V_i = 100\text{dB}\mu$	1.05	1.5	2.05	V
Residual Noise	$V_N$	$V_o (AF) (V_i = 100\text{dB}\mu)$ $V_o (AF) (V_i = -10\text{dB}\mu)$		45		dB
Muting Attenuation	$ATT_{MUTE}$	$V_i = 37\text{dB}\mu$ , Mute SW on		35		dB

AM Section ( $f = 455\text{KHz}$ ,  $f_m = 1\text{KHz}$ , 30% Mod)

Quiescent Circuit Current	$I_{CCQ}$	$V_i = 0$		8		mA
Maximum Sensitivity	$S_{MAX}$	$V_o (AF) = 10\text{mV}$		29		$\text{dB}\mu$
Detector Output Voltage	$V_O$	$V_i = 74\text{dB}\mu$	45	65	85	mV
Total Harmonic Distortion	THD	$V_i = 74\text{dB}\mu$		0.3	2.0	%
		$V_i = 100\text{dB}\mu$		0.7	3.5	%
Signal to Noise Ratio	S/N	$V_i = 74\text{dB}\mu$	45	55		$\text{dB}\mu$
Signal Meter Output	$V_M$	$V_i = 100\text{dB}\mu$	1.2	1.4	1.6	V
Input Impedance (Pin 16)	$Z_i$	Pin 16 0.8-0.9 $V_{DC}$	1.45	2.12	2.8	K $\Omega$

TEST CIRCUIT

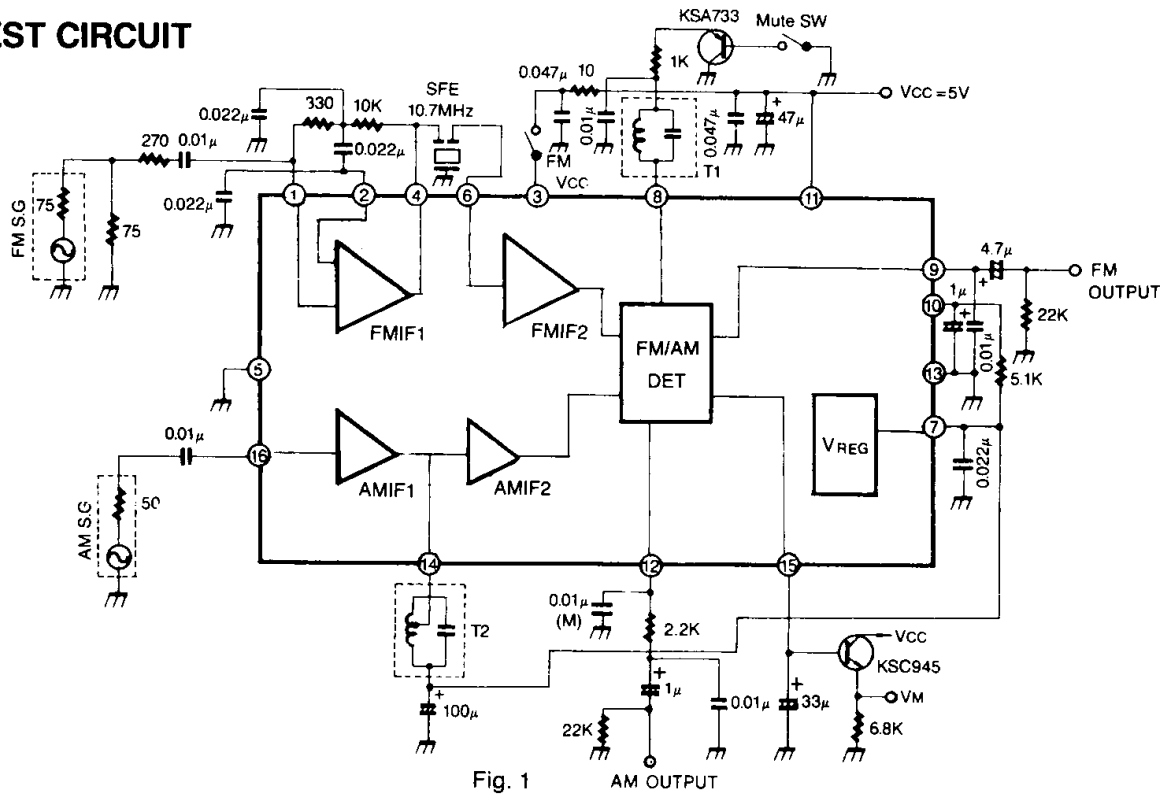
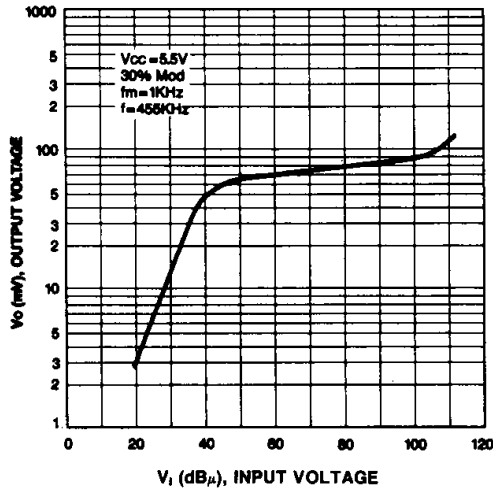

Fig. 1

3

(AM Section)

OUTPUT VOLTAGE-INPUT VOLTAGE



TOTAL HARMONIC DISTORTION-INPUT VOLTAGE

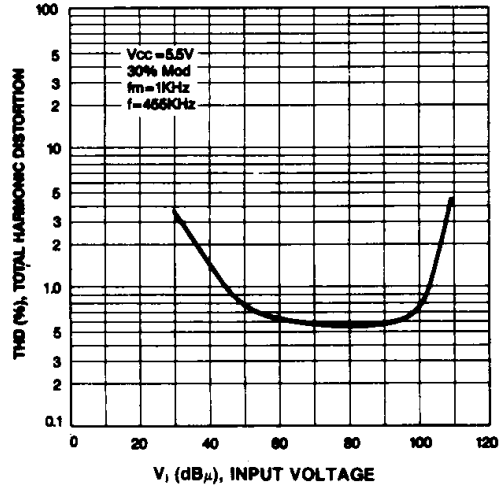

SIGNAL TO NOISE RATIO-INPUT VOLTAGE

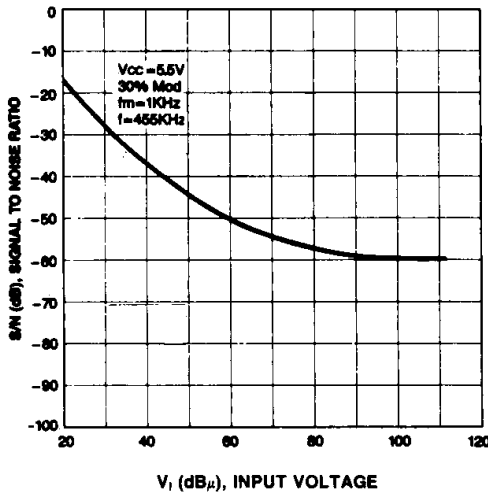

SIGNAL METER OUTPUT VOLTAGE-INPUT VOLTAGE

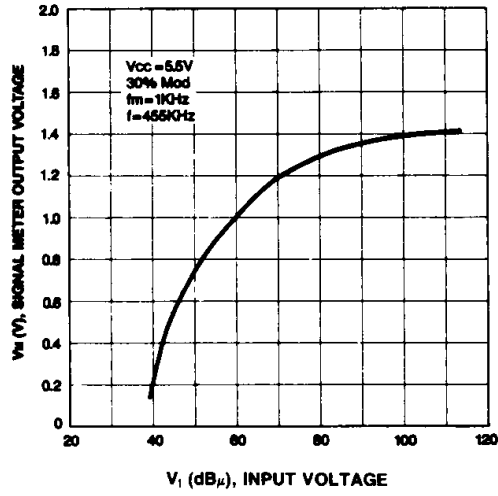

OUTPUT VOLTAGE-SUPPLY VOLTAGE

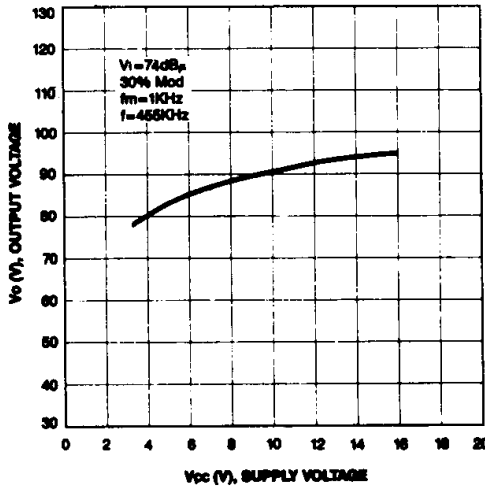

TOTAL HARMONIC DISTORTION-SUPPLY VOLTAGE

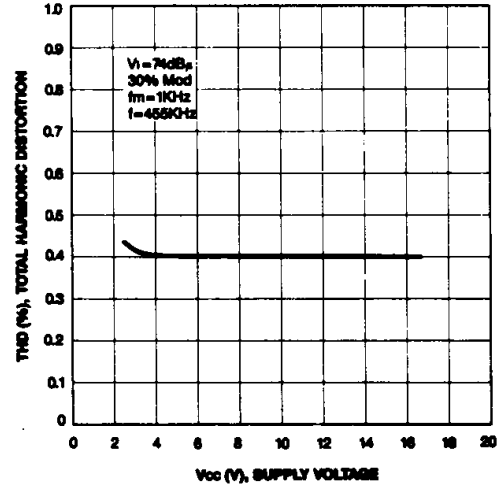

QUIESCENT CIRCUIT CURRENT-SUPPLY VOLTAGE

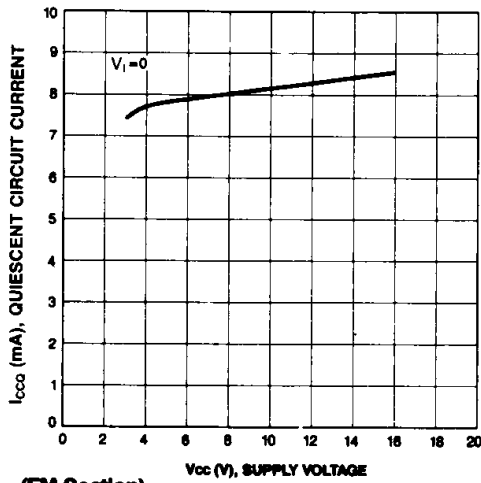

OUTPUT VOLTAGE — MODULATION  
TOTAL HARMONIC DISTORTION

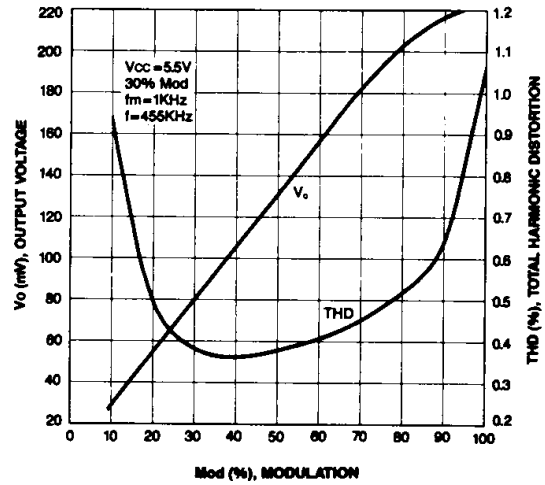

(FM Section)

OUTPUT VOLTAGE-INPUT VOLTAGE

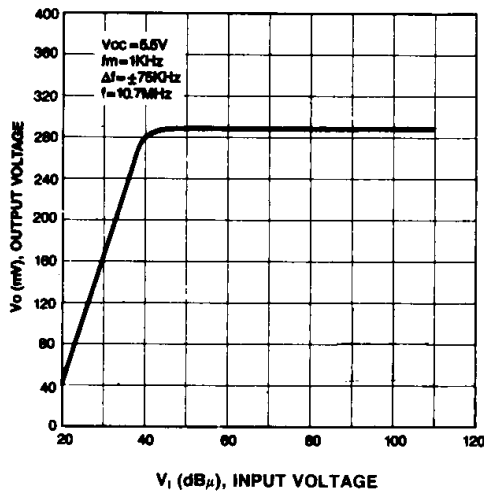

TOTAL HARMONIC DISTORTION-INPUT VOLTAGE

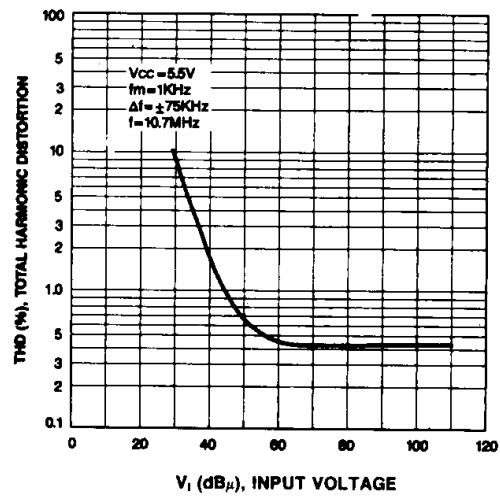

SIGNAL TO NOISE RATIO-INPUT VOLTAGE

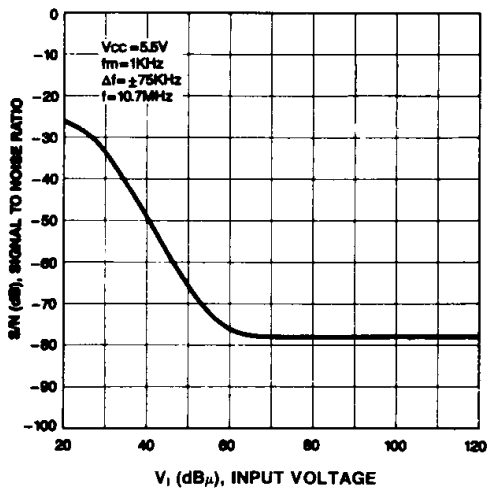

AM REJECTION RATIO-INPUT VOLTAGE

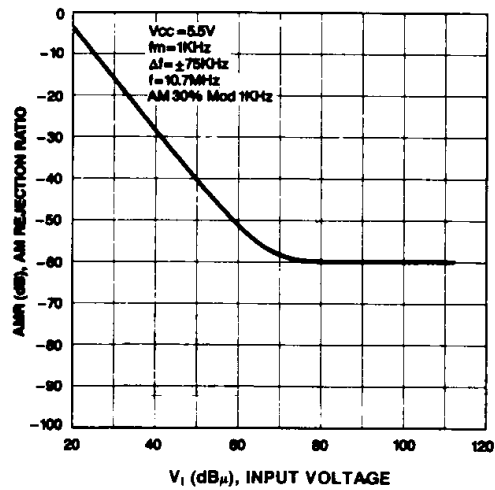

SIGNAL METER OUTPUT VOLTAGE-INPUT VOLTAGE

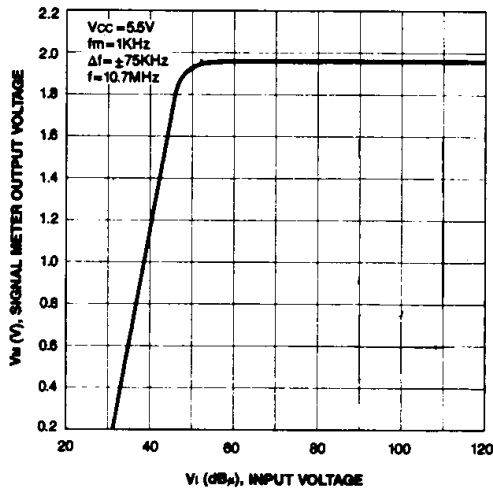

OUTPUT VOLTAGE-SUPPLY VOLTAGE

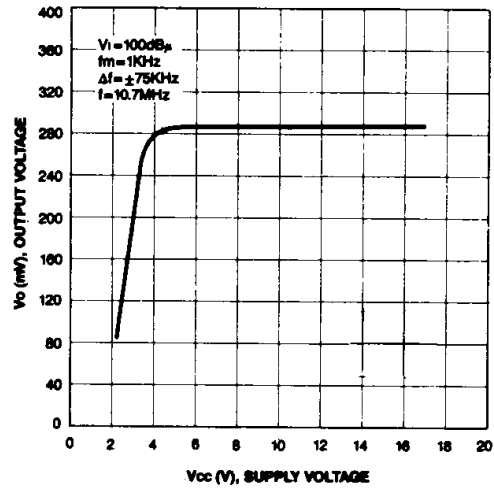

TOTAL HARMONIC DISTORTION-SUPPLY VOLTAGE

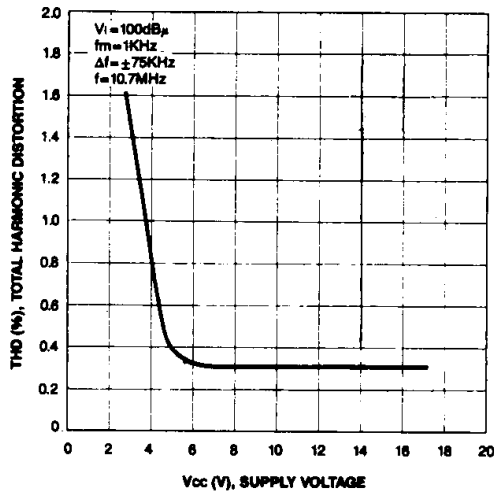

OUTPUT VOLTAGE-INPUT FREQUENCY

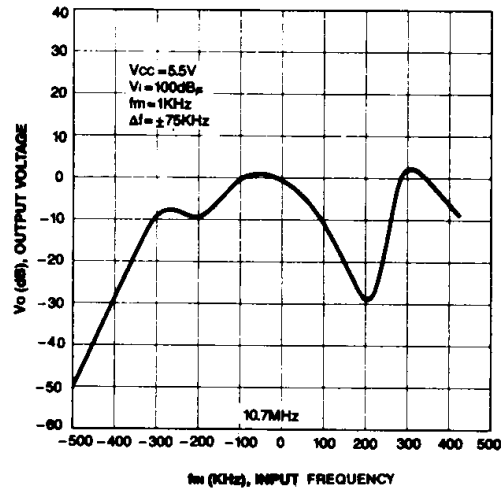

QUIESCENT CIRCUIT CURRENT-SUPPLY VOLTAGE

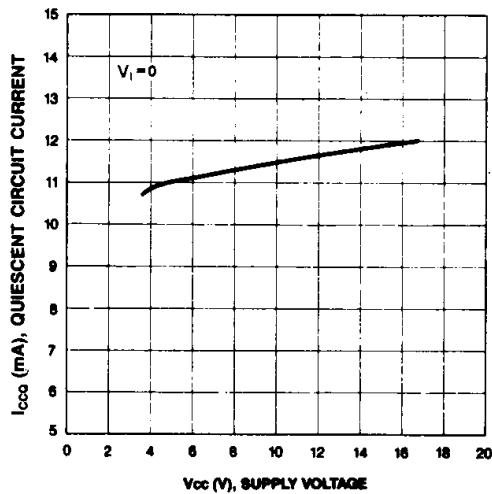

APPLICATION CIRCUIT

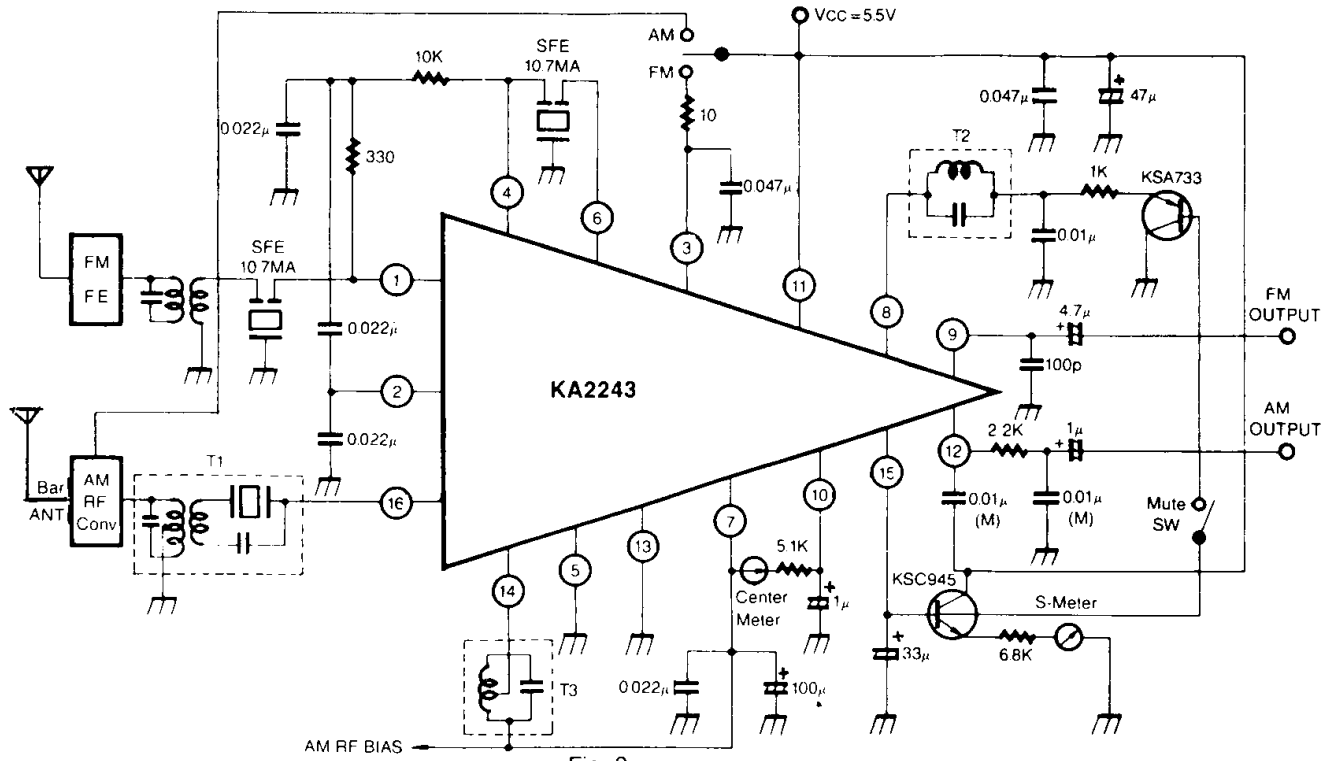
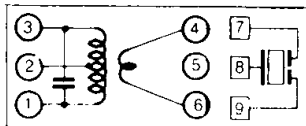

Fig. 2

COIL SPECIFICATION

1. T1



C <sub>o</sub> (pF)	f (KHz)	Q <sub>o</sub> (%)	TURNS		
			4-6	3-2	2-1
180	455	105	6	93	55

Seoul Jupa  
SJ-015-552  
0.06mmφ UEW

2. T2

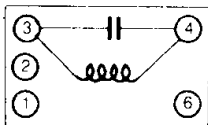

C <sub>o</sub> (pF)	f (MHz)	Q <sub>o</sub> (%)	TURNS		
			3-4		
82	10.7	65	9		

Seoul Jupa  
SJ-59JG-043  
0.07mmφ UEW

3. T3

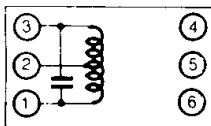

C <sub>o</sub> (pF)	f (KHz)	Q <sub>o</sub> (%)	TURNS	
			1-2	2-3
180	455	120	51	92

Seoul Jupa  
SJ-015-521  
0.07mmφ UEW