

KA2425A

SPEECH NETWORK WITH DIALER INTERFACE

INTRODUCTION

The KA2425A is telephone speech network integrated circuit which includes transmit amp, receive amp, side tone amp, DC loop interface function, DTMF input, voltage regulator for speech, a regulated output voltage for a dialer, and equalization circuit .

FEATURES

- Low voltage operation (1.5v : speech)
- Transmit, receive, side tone and DTMF level are controlled by external resistors
- Regulated voltage for dialer
- Loop length equalization
- MUTE function
- Linear interface for DTMF

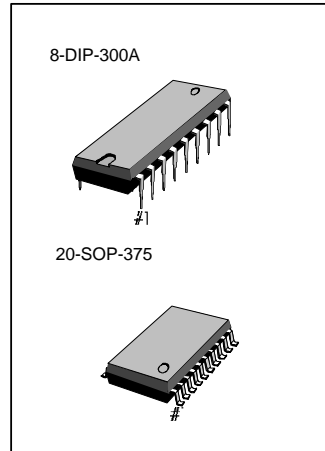

ORDERING INFORMATION

Device	Package	Operating Temperature
KA2425B	18-DIP-300A	- 20°C ~ + 60°C
KA2425AD	20-SOP-375	

PIN CONFIGURATION

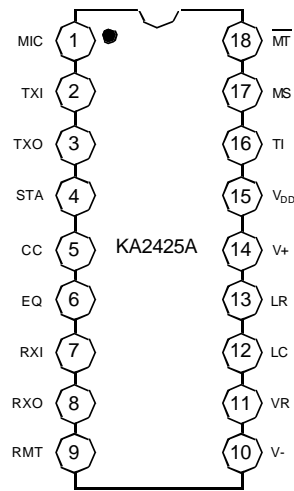

ABSOLUTE MAXIMUM RATINGS

Characteristic	Symbol	Value	Unit
V _s Voltage	V _C	-1.0 ~ +18	V
V _{DD} (V _s = 0)	V _{DD}	-1.0 ~ +6	V
MT,MS inputs	V _M	-1.0 ~ V _{DD} +1	V
V _{LR}	V _{LR}	-1.0V~ V _s -3.0	V
Storage Temperature	T _{STG}	-65 ~ +150	°C

RECOMMENDED OPERATING CONDITIONS (T_a = 25°C)

Characteristic	Symbol	Value	Unit
I _{TXO} (Instantaneous)	I _{CC}	0 ~ 10	mA
V _s (Voltage :Speech Mode)	V _{s(SM)}	+1.5 ~ +15	V
Tone Dialing Mode	V _{s(TM)}	+3.3 ~ +15	V
Operating Temperature	T _{ORR}	-20 ~ +60	°C

ELECTRICAL CHARACTERISTICS (T_a = 25°C)

Characteristic	Symbol	Test Conditions	Min	Typ	Max	Unit
SYSTEM SPECIFICATIONS (Refer to Fig.3 and Fig.4)						
T _X Gain from V _S to V _s	G _{V(TX)}	Figure (I _L = 20mA) I _L = 60mA	28	29.5	31	dB
Gain Change	ΔG _{V(TX)}		-6.0	-4.5	-3.6	dB
Distortion	THD _{TX}		-	2.0	-	%
Output Noise	V _{NO(TX)}		-	11	-	dBmc
R _X	G _{V(RX)}	f = 1.0KHz, I _L = 20mA (See Figure.4) I _L = 60mA	-16	-15	-13	dB
V _{RXO} / V _S	ΔG _{V(RX)}		-5.0	-3.0	-2.0	dB
R _X Gain Change	THD _{RX}		-	2.0	-	%
Distortion						
DTMF Driver	G _{V(MF)}	I _L = 20mA	3.2	4.8	6.2	dB
V _s / V _{IN}						
Sidetone Level	G _{V(ST)}	I _L = 20mA	-	-28	-	dB
V _{RXO} / V _s		I _L = 60mA	-	-13	-	dB
Sidetone Rejection	RST	I _L = 20mA	12	18	-	dB
$\frac{V_{RXO}}{V_{s}}$ (Figure 4) dB - $\frac{V_{RXO}}{V_{s}}$ (Figer 3) dB						
Tip-Ring Voltage (including polarity guard bridge drop of 1.4v) (Speech Mode)	V _{TR}	I _L = 5.0mA I _L = 10mA I _L = 20mA I _L = 40mA I _L = 60mA	- - - - -	2.4 3.9 4.6 5.6 6.6	- - - - -	V _{DC}
AC impedance	Z _{ac}	I _L = 20mA I _L = 60mA 20mA < I _L , 60mA	- - -	750 300 1650	- - -	Ω
Speech mode (incl. C ₆ , See Figure 4)						
Z _{ac} = (600)V +/- (V _S - V _s)						
Tone Mode (including C ₆)						

None : Typicals are tested or guaranteed.



ELECTRONICS

ELECTRICAL CHARACTERISTICS (Continued)

Characteristic	Symbol	Test Conditions	Min	Typ	Max	Unit
SYSTEM AMPLIFIERS						
T_x						
Gain	$G_V(TX)$	TXI to TXO	24	26	28	dB
TXO Bias Voltage	$V_{BIAS(SPM)}$	Speech/Pulse Mode	0.45	0.52	0.60	xV_R
TXO Bias Voltage	$V_{BIAS(TM)}$	Tone Mode	$V_R - 25$	$V_R - 5.0$	-	mV
TXO Bias Voltage	$V_{OL(SPM)}$	Speech/Pulse Mode	$V_R - 25$	$V_R - 5.0$	-	mV
TXO Bias Voltage	$V_{OL(SPM)}$	Speech/Pulse Mode	-	125	250	mV
TXI input Resistance	$R_I(TXI)$		-	10	-	$K\Omega$
R_x						
RXO Bias voltage	$V_{BIAS(AM)}$	All Mode	0.45	0.52	0.60	xV_R
RXO Source current	$I_{SOURCE(SM)}$	Speech Mode	1.5	2.0	-	mA
RXO Source current	$I_{SOURCE(PTM)}$	Pulse/tone Mode	200	400	-	μA
RXO High Voltage	$V_{OH(AM)}$	All Mode	$V_R - 100$	$V_R - 50$	-	mV
RXO Low Voltage	$V_{OL(AM)}$	All Mode	-	50	150	mV
SIDETONE AMPLIFIER						
Gain (TXO to STA)						
Speech Mode	$G_V(STA)$	@ $V_{LR} = 0.5V$	-	-15	-	dB
Speech Mode		@ $V_{LR} = 2.5V$	-	-21	-	
Pulse Mode		@ $V_{LR} = 0.2V$	-	-15	-	
Pulse Mode		@ $V_{LR} = 1.0V$	-	-21	-	
STA Bias Voltage	$V_{BIAS(STA)}$	All Modes	0.65	0.8	0.9	xV_R
MICROPHONE, RECEIVER CONTROLS						
MIC Saturation Voltage	$V_{SAT(MIC)}$	Speech Mode, $I = 500\mu A$	-	50	125	mV
MIC Leakage Current	$I_{LKG(MIC)}$	Dialing Mode, Pin 1=3.0V	-	0	5.0	μA
RMT Resistance	$R_{RMT(SM)}$	Speech Mode	-	8.0	15	Ω
	$R_{RMT(DM)}$	Dialing Mode	5.0	10	18	$K\Omega$
RMT Delay	$t_D(RMT)$	Dialing to Speech	2.0	4.0	20	ms
EQUALIZATION AMPLIFIER						
GAIN (V + to EQ)						
Speech Mode	$G_V(EQ)$	@ $V_{LR} = 0.5V$	-	-12	-	dB
Speech Mode		@ $V_{LR} = 2.5V$	-	-2.5	-	
Pulse Mode		@ $V_{LR} = 0.2V$	-	-12	-	
Pulse Mode		@ $V_{LR} = 1.0V$	-	-2.5	-	
EQ Bias Voltage	$V_{BIAS(EQ)}$					
Speech Mode	$V_{BIAS(EQ)}$	@ $V_{LR} = 0.5V$	-	0.66	-	V_{DC}
Pulse Mode		@ $V_{LR} = 0.5V$	-	1.3	-	
Speech, Pulse Mode		@ $V_{LR} = 2.5V$	-	3.3	-	



ELECTRICAL CHARACTERISTICS (Continued)

Characteristic	Symbol	Test Conditions	Min	Typ	Max	Unit
DIALING INTERFACE						
MT Input Resistance	$R_{1(MT)}$	-	50	100	-	K Ω
MT Input High Voltage	$V_{IH(MT)}$	-	$V_{DD}-0.3$	-	-	V_{dc}
MT Input Low Voltage	$V_{IL(MT)}$	-	-	-	1.0	V_{dc}
MS Input Resistance	$R_{1(MS)}$	-	280	600	-	K Ω
MS Input High Voltage	$V_{IH(MS)}$	-	2.0	-	-	V_{dc}
MS Input Low Voltage	$V_{IL(MS)}$	-	-	-	0.3	V_{dc}
TI Input Resistance	$R_{1(TI)}$	-	-	1.25	-	K Ω
DTMF Gain	$G_V(MF)$	-	3.2	4.8	6.2	dB
LINE INTERFACE						
V+ Current (Pin 12 Grounded)	1+	V+ = 1.7V V+ = 12V V+ = 12V	4.5 5.5 6.0	7.1 8.4 8.8	9.0 12.5 14.0	mA
Speech Mode						
Speech/Pulse Modes						
Tone Mode						
V+ Voltage	V+	$I_L = 20mA$ $I_L = 30mA$ $I_L = 120mA$ $I_L = 20mA$ $I_L = 30mA$	2.6 3.0 7.0 4.1 4.5	3.2 3.7 8.2 4.9 6.4	3.8 4.4 9.5 5.7 6.2	V_{dc}
Speech/Pulse Mode						
Speech/Pulse Mode						
Speech/Pulse Mode						
Tone Mode						
Tone Mode						
LR Level Shift	ΔV_{LR}	V + - V_{LR}	-	2.7 4.3	-	V_{dc}
Speech/Pulse Mode						
Tone Mode						
LC Terminal Resistance	R_{LC}	-	36	57	94	K Ω
VOLTAGE REGULATORS						
VR Voltage	V_R	(V+ = 1.7V)	1.1	1.2	1.3	V_{dc}
Load Regulation	ΔV_O	$0mA < I_R < 1.6mA$	-	20	-	mV
Line Regulation	ΔV_O	$2.0V < V+ < 6.5V$	-	25	-	mV
V _{DD} Voltage	V_{DD}	(V+ = 4.5V)	3.0	3.3	3.8	V_{dd}
Load Regulation (Dialing Mode)	$\Delta V_O(DM)$	$0 < I_{DD} < 1.6mA$	-	0.25	-	V_{dd}
Line Regulation (All Modes)	$\Delta V_O(AM)$	$4.0V < V+ < 9.0V$	-	50	-	mV
Max. Output Current	$I_{OSM(MAX)}$	Speech Mode	375	550	1000	μA
Max. Output Current	$I_{ODM(MAX)}$	Dialing Mode	1.6	2.0	3.6	mA
V _{DD} Leakage Current	$I_{LKG(VDD)}$	V+ = 0, V _{DD} = 3.0V	-	-	1.5	μA



KA2425A

SPEECH NETWORK WITH DIALER INTERFACE

TEST CIRCUIT

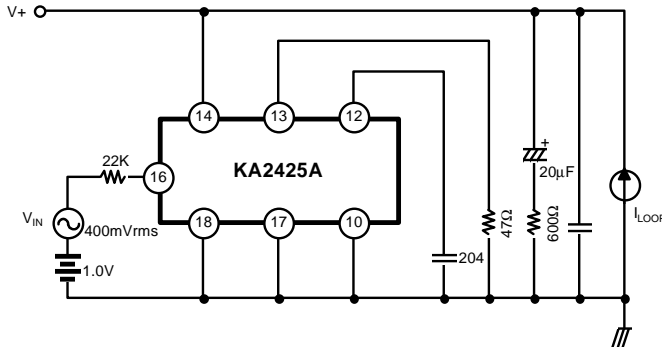

Fig 2. DTMF Driver Test

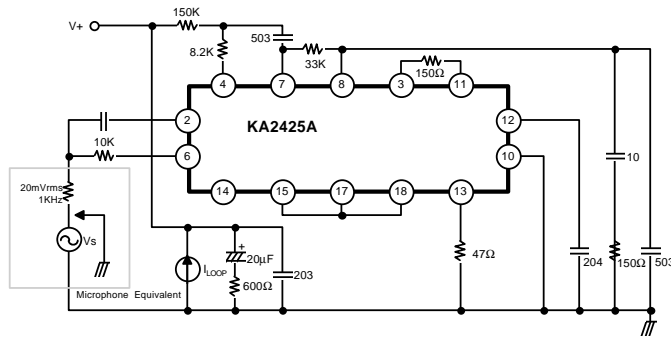

Fig 3. Transmit and sidetone level test

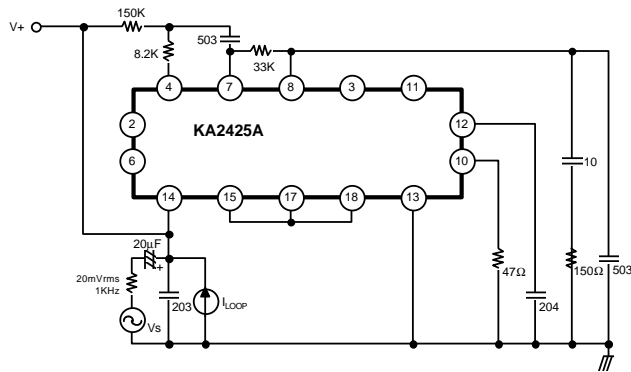

Fig 4. AC Impedance, Receive and Sidetone Rejection Test



KA2425A

SPEECH NETWORK WITH DIALER INTERFACE

APPLICATION CIRCUIT

