

SANYO	No. ※ 5039	LC74763, 74763M
		On-Screen Display LSI

Preliminary

Overview

The LC74763 and LC74763M are on-screen display CMOS LSIs that superimpose text and low-level graphics onto a TV screen (video signal) under the control of a microcontroller. The display characters have a 12 by 18 dots structure, and 128 characters are provided.

Features

- Display structure: 12 lines by 24 characters (up to 288 characters)
- Maximum character display: Up to 288 characters
- Character configuration: 12 (W) by 18 (H) dots structure
- Number of characters: 128 characters (128 plus space 2 fonts)
- Character sizes: Three sizes (normal, double, and triple sizes)
- Display starting positions: 64 horizontal and 64 vertical locations
- Reverse video function: Characters can be inverted on a per character basis.
- Flashing types: Two types with periods of 0.5 and 1.0 second on a per character basis (duty fixed at 50%)
- Background color: One of eight colors (when internal synchronization used)
- External control input: Serial data input in 8-bit units
- Built-in horizontal/vertical sync separation circuit, AFC circuit, and synchronization detector
- Video output: Composite video signal output in NTSC, PAL, PAL-M, PAL-N, PAL60, NTSC4.43, or SECAM format

Package Dimensions

unit: mm

3196-DIP30SD

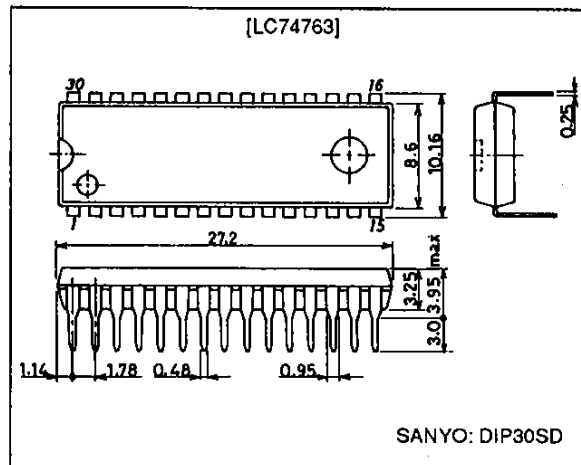

3216A-MFP30S

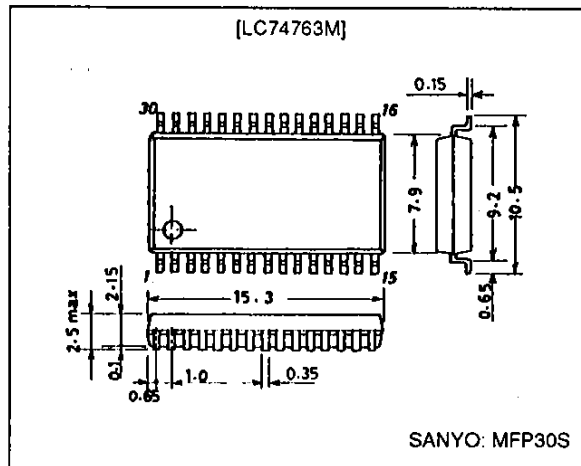

Specifications

Absolute Maximum Ratings at Ta = 25°C

Parameter	Symbol	Conditions	Ratings	Unit
Maximum supply voltage	V _{DD max}	V _{DD1} , V _{DD2} pins	V _{SS} - 0.3 to V _{SS} + 7.0	V
Maximum input voltage	V _{IN max}	All input pins	V _{SS} - 0.3 to V _{DD} + 0.3	V
Maximum output voltage	V _{OUT max}	HSYNC _{OUT} , VSYNC _{OUT} , SYNC _{DET} pins	V _{SS} - 0.3 to V _{DD} + 0.3	V
Allowable power dissipation	Pd max		300	mW
Operating temperature	T _{opr}		-30 to +70	°C
Storage temperature	T _{stg}		-40 to +125	°C

Allowable Operating Ranges at Ta = -30 to +70°C

Parameter	Symbol	Conditions	Ratings			Unit
			min	typ	max	
Supply voltage	V _{DD1}	V _{DD1} pin	4.5	5.0	5.5	V
	V _{DD2}	V _{DD2} pin	4.5	5.0	1.27 V _{DD1}	V
Input high level voltage	V _{IH1}	RST, CS, SIN, SCLK pins	0.8 V _{DD1}		V _{DD1} + 0.3	V
	V _{IH2}	SECAM, 525/625, NTSC/PAL, 3.58/4.43 pins	0.7 V _{DD1}		V _{DD1} + 0.3	V
Input low level voltage	V _{IL1}	RST, CS, SIN, SCLK	V _{SS} - 0.3		0.2 V _{DD1}	V
	V _{IL2}	SECAM, 525/625, NTSC/PAL, 3.58/4.43 pins	V _{SS} - 0.3		0.3 V _{DD1}	V
Input voltage	V _{IN}	FC, AMP _{IN} pins	V _{SS} - 0.3		V _{DD1} + 0.3	V
Composite video signal input voltage	V _{IN1}	CV _{IN} pins		2 V _{PP}		V
	V _{IN2}	CV _{CR} pins		2 V _{PP}		V
	V _{IN3}	SYNC _{IN} pins		2 V _{PP}	2.5 V _{PP}	V
Oscillator frequency	F _{OSC1}	Xtal _{IN1} , Xtal _{OUT1} , Xtal _{IN2} , Xtal _{OUT2} pins; 4fsc	NTSC		14.318	MHz
			PAL		17.734	MHz
			PAL-M		14.302	MHz
			PAL-N		14.328	MHz

Electrical Characteristics at Ta = -30 to +70°C, with V_{DD1} = V_{DD2} = 5 V unless otherwise specified

Parameter	Symbol	Conditions	Ratings			Unit
			min	typ	max	
Output off leakage current	I _{leak1}	CV _{OUT} pin			10	μA
Input off leakage current	I _{leak2}	CV _{IN} , CV _{CR} pins			10	μA
Output high level voltage	V _{OH}	HSYNC _{OUT} , VSYNC _{OUT} , SYNC _{DET} , SECAM, 525/625, NTSC/PAL, 3.58/4.43, AMP _{OUT} , PD _{OUT} pins; V _{DD1} = 4.5 V, I _{OH} = -1.0 mA	3.5			V
Output low level voltage	V _{OL}	HSYNC _{OUT} , VSYNC _{OUT} , SYNC _{DET} , SECAM, 525/625, NTSC/PAL, 3.58/4.43, AMP _{OUT} , PD _{OUT} pins; V _{DD1} = 4.5 V, I _{OL} = 1.0 mA			1.0	V
Input current	I _{IH}	RST, CS, SIN, SCLK, SECAM, 525/625, NTSC/PAL, 3.58/4.43 pins; V _{IN} = V _{DD1}			1	μA
	I _{IL}	SECAM, 525/625, NTSC/PAL, 3.58/4.43 pin; V _{IN} = V _{SS1}	-1			μA
Oscillator frequency	F _{OSC3}	VCO _{IN} , VCO _{OUT} pins; FC = 1/2 V _{DD1}		14.12		MHz
Operating current dissipation	I _{DD1}	V _{DD1} pin; All outputs open, Xtal: 4fsc			15	mA
	I _{DD2}	V _{DD2} pin; V _{DD2} = 5.0 V			20	mA

Timing Characteristics at Ta = -30 to +70°C, V_{DD} = 5 ± 0.5 V

Parameter	Symbol	Conditions	Ratings			Unit
			min	typ	max	
Minimum input pulse width	t _{w(SCLK)}	SCLK pin	200			ns
	t _{w(CS)}	CS pin (during periods when CS is high)	1			μs
Data setup time	t _{SU(CS)}	CS pin	200			ns
	t _{SU(SIN)}	SIN pin	200			ns
Data hold time	t _{H(CS)}	CS pin	2			μs
	t _{H(SIN)}	SIN pin	200			ns
One word write time	t _{word}	Write time for 8 bits of data	4.2			μs
	t _{wt}	RAM data write time	1			μs

Pin Functions

Pin No.	Symbol	Function	Description
1	V _{SS}	Ground	Ground connection
2	Xtal _{IN1}	Crystal oscillator connection	Connection for the crystal and capacitor used to form the crystal oscillator that generates the internal synchronization signal. The oscillator can be selected with a command switch.
3	Xtal _{OUT1}		
4	H _{SYNC} _{OUT}	Horizontal synchronization output	Outputs the horizontal synchronization signal (AFC). The output polarity can be selected (metal option). Also functions as general output port (command switch).
5	Xtal _{IN2}	Crystal oscillator connection	Connection for the crystal and capacitor used to form the crystal oscillator that generates the internal synchronization signal.
6	Xtal _{OUT2}		
7	V _{SYNC} _{OUT}	Vertical synchronization output	Outputs the vertical synchronization signal. The output polarity can be selected (metal option). Also functions as general output port (command switch).
8	\overline{CS}	Enable input	Enables/disables serial data input. Serial data is enabled when this pin is low (hysteresis input). Pull-up resistor built in (metal option).
9	SIN	Data input	Serial data input (hysteresis input). Pull-up resistor built in (metal option).
10	SCLK	Clock input	Clock input for serial data input (hysteresis input). Pull-up resistor built in (metal option).
11	SECAM	SECAM mode switch input/output (command switch)	During input, switches between SECAM and other modes. During output, functions as general output port or internal V output (command switch). Low = other modes, high = SECAM mode
12	$\overline{525/625}$	525/625 switch input/output (command switch)	During input, switches between 525 scan lines and 625 scan lines. During output, functions as general output port or character data output (command switch). Low = 525 lines, high = 625 lines
13	$\overline{NTSC/PAL}$	NTSC/PAL switch input/output (command switch)	Switches the color mode between NTSC and PAL. During output, functions as general output port or frame data output (command switch). Low = NTSC, high = PAL
14	$\overline{3.58/4.43}$	3.58/4.43 switch input/output (command switch)	Switch FSC between 3.58 MHz and 4.43 MHz. During output, functions as general output port or halftone output (command switch). Low = 3.58, high = 4.43
15	\overline{RST}	Reset input	System reset input pin, low is active (hysteresis input). Pull-up resistor built in (metal option).
16	CV _{OUT}	Video signal output	Composite video output
17	V _{DD2}	Power supply connection	Power supply connection for composite video signal level generation
18	CV _{IN}	Video signal input	Composite video input
19	CV _{CR}	Video signal input	SECAM chroma signal input
20	SYNC _{IN}	Sync separator circuit input	Built-in sync separator circuit video signal input
21	SEP _C	Sync separator circuit	Built-in sync separator circuit
22	V _{SS}	Ground	Ground connection
23	PD _{OUT}	Control voltage output	AFC control voltage output
24	AMP _{IN}	AFC filter connection	Filter connection
25	AMP _{OUT}		
26	FC	Control voltage input	AFC control voltage input
27	VCO _{IN}	LC oscillator connection	VCO LC oscillator circuit coil and capacitor connection
28	VCO _{OUT}		
29	SYNC _{DET}	External synchronization signal detection output	Outputs the exclusive NOR of the horizontal synchronization signal (AFC) and CSYNC (sync separator). The output polarity can be selected (metal option). Also functions as general output port (command switch).
30	V _{DD1}	Power supply connection	Power supply connection (+5 V: digital system power supply)

Pin Assignment

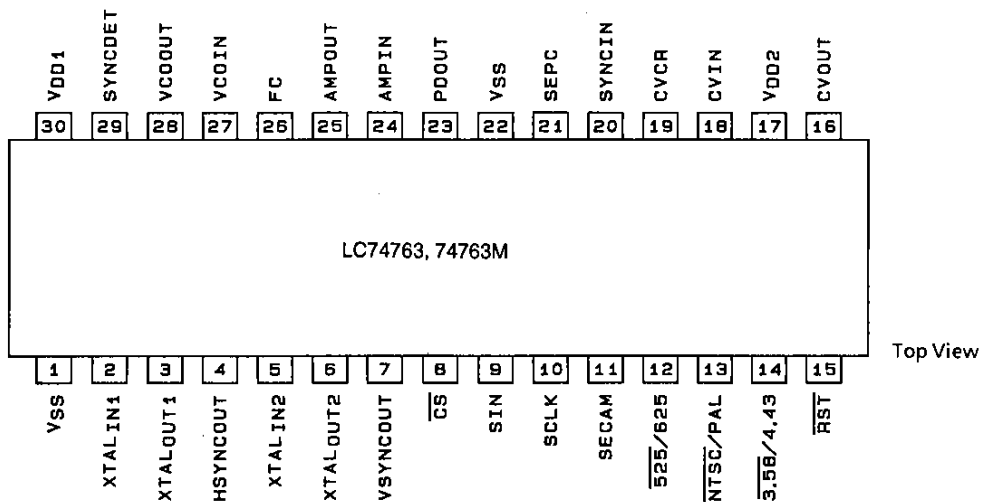

A03518

Serial Data Input Timing

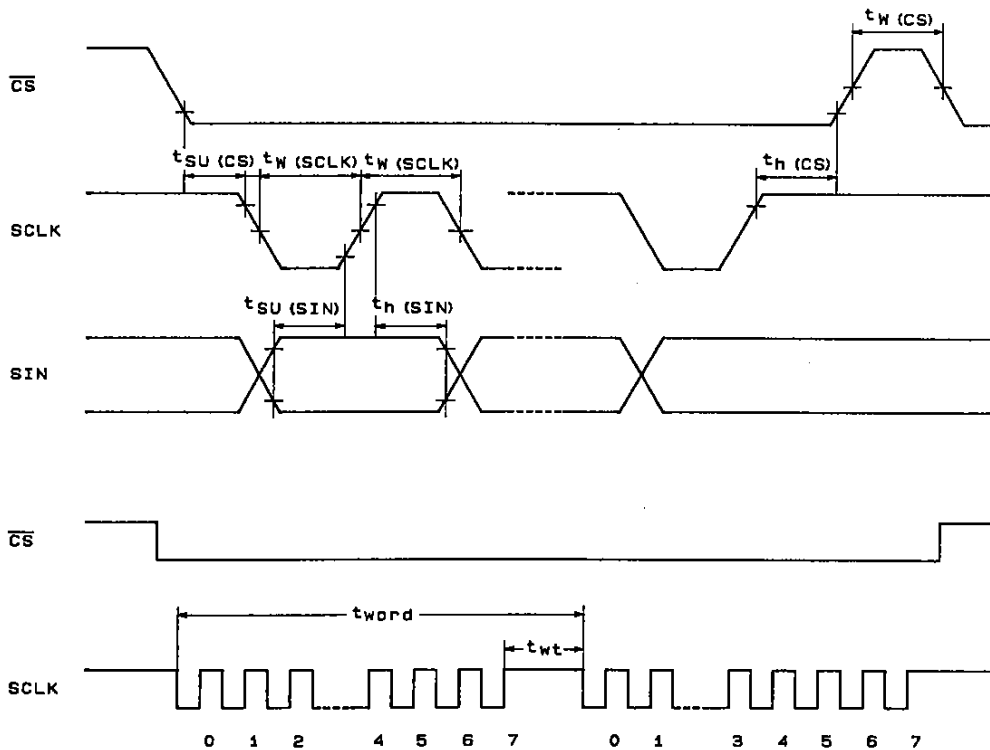

A03519

System Block Diagram

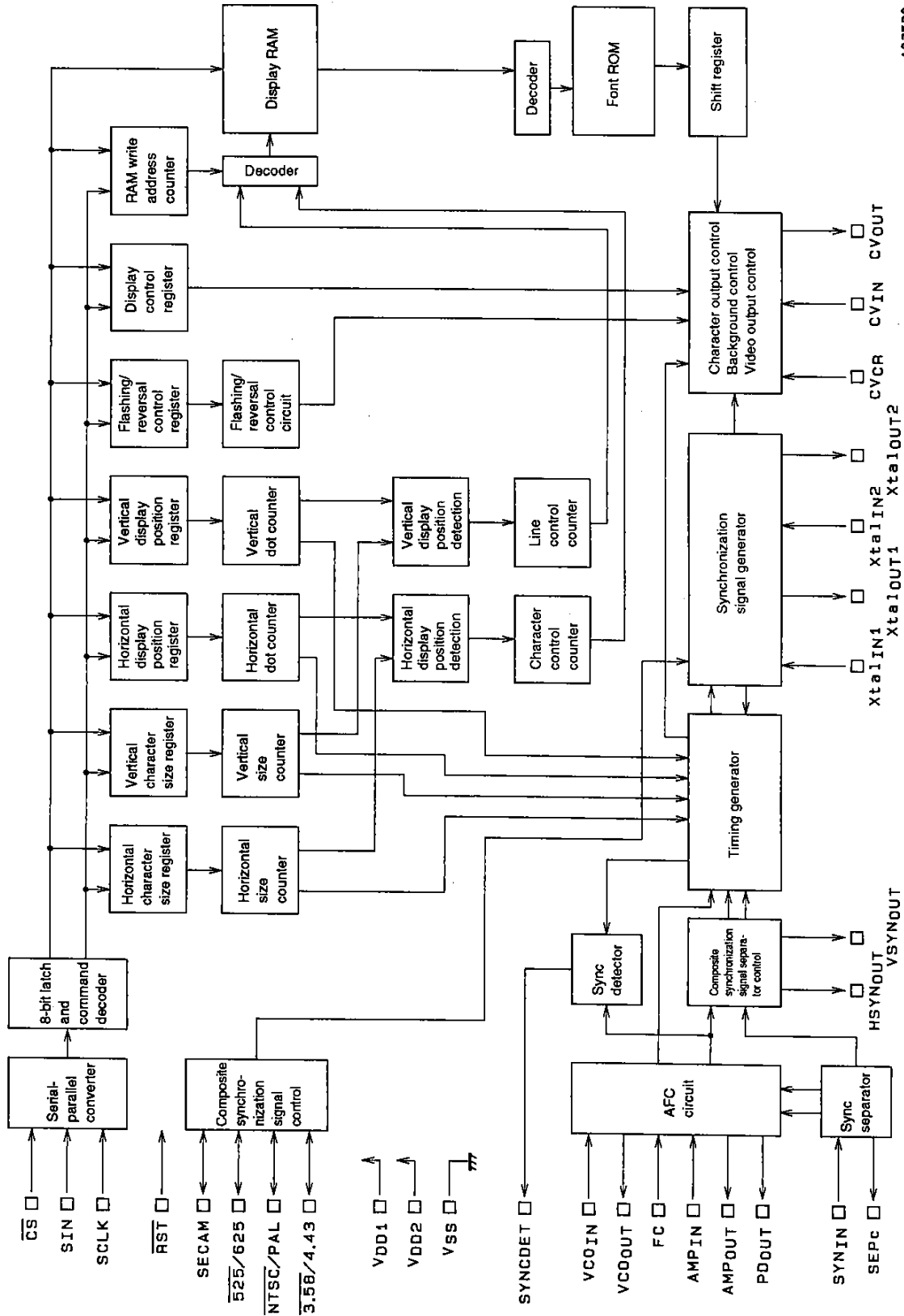

A03520

Display Control Commands

Display control commands are input in an 8-bit serial format. Commands consist of a command identification code in the first byte and data in the second and following bytes. The following commands are supported.

- ① COMMAND0: Display memory (VRAM) write address setting command
- ② COMMAND1: Display character data write command
- ③ COMMAND2: Vertical display start position and character size (lines 1 and 2) setting command
- ④ COMMAND3: Horizontal display start position and character size (lines 9 and 11) setting command
- ⑤ COMMAND4: Display control setting command 1
- ⑥ COMMAND5: Display control setting command 2
- ⑦ COMMAND6: Display control setting command 3
- ⑧ COMMAND7: Display control setting command 4

Display Control Command Table

Command	First byte								Second byte							
	Command identification code				Data				Data							
	7	6	5	4	3	2	1	0	7	6	5	4	3	2	1	0
COMMAND0 Write address	1	0	0	0	V3	V2	V1	V0	0	0	0	H4	H3	H2	H1	H0
COMMAND1 Character write	1	0	0	1	0	0	a12	a11	c7	c6	c5	c4	c3	c2	c1	c0
COMMAND2 Vertical display start position	1	0	1	0	SZ	SZ	SZ	SZ	0	0	VP	VP	VP	VP	VP	VP
COMMAND3 Horizontal display start position	1	0	1	1	SZ	SZ	SZ	SZ	0	0	HP	HP	HP	HP	HP	HP
COMMAND4 Display control 1	1	1	0	0	RST	RAM	OSC	RND	0	I/N	BLK	BLK	BK	ATS	0	DSP
COMMAND5 Display control 2	1	1	0	1	PH	PH	PH	I/E	0	TST	CHAL	BKL	RSL	RSL	CVM	XTS
COMMAND6 Display control 3	1	1	1	0	MOD	MOD	MOD	MOD	0	HFI	M30S	SMS	IOS	BCL	BCL	CB
COMMAND70 Display control 4	1	1	1	1	0	0	0	LINS	0	VCOS	LIN	LIN	LIN	LIN	LIN	LIN
COMMAND71 Display control 5	1	1	1	1	0	1	0	LINS	0	EG	PS	PS	VMN	SVIS	VNS	VSS
COMMAND72 Display control 6	1	1	1	1	1	0	0	LINS	0	0	0	0	MOD	MOD	MOD	MOD
COMMAND73 Display control 7	1	1	1	1	1	1	0	LINS	0	0	0	0	VCOS	SOUT	VOUT	HOUT

Once the command identification code in the first byte is written, it is stored internally until the first byte of the following command is written. However, when the display character data write command (COMMAND1) is written, the system becomes locked in display character data write mode, and the first byte cannot be overwritten.

When the \overline{CS} pin is set high the command state is set to COMMAND0, i.e., display memory write address setting mode.

① COMMAND0: Display Memory Write Address Setting Command

First data byte

DA0 to DA7	Register name	Register content		Note
		State	Function	
7	—	1	The command 0 identification code: sets the display memory write address.	
6	—	0		
5	—	0		
4	—	0		
3	V3	0	Display memory line address (from 0 to B (hexadecimal))	
		1		
2	V2	0		
		1		
1	V1	0		
		1		
0	V0	0		
		1		

Second byte

DA0 to DA7	Register name	Register content		Note
		State	Function	
7	—	0	Second byte identification code	
6	—	0		
5	—	0		
4	H4	0	Display memory character address (from 0 to 17 (hexadecimal))	
		1		
3	H3	0		
		1		
2	H2	0		
		1		
1	H1	0		
		1		
0	H0	0		
		1		

Note: When the chip is reset by the RST pin, the register states (bits) are all cleared to 0.

② COMMAND1: Display Character Data Write Setting Command

First byte

DA0 to DA7	Register name	Register content		Note
		State	Function	
7	—	1	The command 1 identification code: sets the display memory write address.	When this command is entered, the chip locks in display character write mode until the CS pin is set high.
6	—	0		
5	—	0		
4	—	1		
3	—	0		
2	—	0		
1	at2	0	Turns character attribute 2 off.	Specifies highlight or flashing.
		1	Turns character attribute 2 on.	
0	at1	0	Turns character attribute 1 off.	Specifies reverse video.
		1	Turns character attribute 1 on.	

Second byte

DA0 to DA7	Register name	Register content		Note
		State	Function	
7	c7	0	Character code (from 00 to 7F, FE, FF)	
		1		
6	c6	0		
		1		
5	c5	0		
		1		
4	c4	0		
		1		
3	c3	0		
		1		
2	c2	0		
		1		
1	c1	0		
		1		
0	c0	0		
		1		

Note: When the chip is reset by the RST pin, the register states (bits) are all cleared to 0.

③ COMMAND2: Vertical Display Position Setting Command

First byte

DA0 to DA7	Register name	Register content		Note									
		State	Function										
7	—	1	The command 2 identification code: sets the vertical display position.										
6	—	0											
5	—	1											
4	—	0											
3	SZ21	0	<table border="1"> <tr> <td>SZ20 \ SZ21</td> <td>0</td> <td>1</td> </tr> <tr> <td>0</td> <td>Normal size</td> <td>Double size</td> </tr> <tr> <td>1</td> <td>Triple size</td> <td>Normal size</td> </tr> </table>	SZ20 \ SZ21	0	1	0	Normal size	Double size	1	Triple size	Normal size	Character size for the second line
		SZ20 \ SZ21		0	1								
0	Normal size	Double size											
1	Triple size	Normal size											
1													
2	SZ20	0	<table border="1"> <tr> <td>SZ10 \ SZ11</td> <td>0</td> <td>1</td> </tr> <tr> <td>0</td> <td>Normal size</td> <td>Double size</td> </tr> <tr> <td>1</td> <td>Triple size</td> <td>Normal size</td> </tr> </table>	SZ10 \ SZ11	0	1	0	Normal size	Double size	1	Triple size	Normal size	Character size for the first line
		SZ10 \ SZ11		0	1								
0	Normal size	Double size											
1	Triple size	Normal size											
1													
1	SZ11	0	<table border="1"> <tr> <td>SZ10 \ SZ11</td> <td>0</td> <td>1</td> </tr> <tr> <td>0</td> <td>Normal size</td> <td>Double size</td> </tr> <tr> <td>1</td> <td>Triple size</td> <td>Normal size</td> </tr> </table>	SZ10 \ SZ11	0	1	0	Normal size	Double size	1	Triple size	Normal size	
		SZ10 \ SZ11		0	1								
0	Normal size	Double size											
1	Triple size	Normal size											
1													
0	SZ10	0	<table border="1"> <tr> <td>SZ10 \ SZ11</td> <td>0</td> <td>1</td> </tr> <tr> <td>0</td> <td>Normal size</td> <td>Double size</td> </tr> <tr> <td>1</td> <td>Triple size</td> <td>Normal size</td> </tr> </table>	SZ10 \ SZ11	0	1	0	Normal size	Double size	1	Triple size	Normal size	
		SZ10 \ SZ11		0	1								
0	Normal size	Double size											
1	Triple size	Normal size											
1													

Second byte

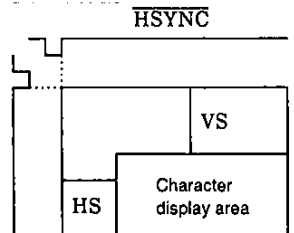
DA0 to DA7	Register name	Register content		Note
		State	Function	
7	—	0	Second byte identification code	
6	—	0		
5	VP5 (MSB)	0	The vertical display start position is given by $VS = H \times \left(\sum_{n=0}^5 2^n VP_n \right)$ where H is the horizontal synchronization pulse period. 	The six bits VP0 to VP5 specify the vertical display start position. The weight of the lsb is 1 × H.
		1		
4	VP4	0		
		1		
3	VP3	0		
		1		
2	VP2	0		
		1		
1	VP1	0		
		1		
0	VP0 (LSB)	0		
		1		

Note: When the chip is reset by the RST pin, the register states (bits) are all cleared to 0.

④ COMMAND3: Horizontal Display Position Setting Command

First byte

DA0 to DA7	Register name	Register content			Note									
		State	Function											
7	—	1	The command 3 identification code: sets the horizontal display position.											
6	—	0												
5	—	1												
4	—	1												
3	SZB1	0	<table border="1"> <tr> <td>SZB0 \ SZB1</td> <td>0</td> <td>1</td> </tr> <tr> <td>0</td> <td>Normal size</td> <td>Double size</td> </tr> <tr> <td>1</td> <td>Triple size</td> <td>Normal size</td> </tr> </table>		SZB0 \ SZB1	0	1	0	Normal size	Double size	1	Triple size	Normal size	The character size for the eleventh line.
		SZB0 \ SZB1	0	1										
0	Normal size	Double size												
1	Triple size	Normal size												
1														
2	SZB0	0	<table border="1"> <tr> <td>SZB0 \ SZB1</td> <td>0</td> <td>1</td> </tr> <tr> <td>0</td> <td>Normal size</td> <td>Double size</td> </tr> <tr> <td>1</td> <td>Triple size</td> <td>Normal size</td> </tr> </table>		SZB0 \ SZB1	0	1	0	Normal size	Double size	1	Triple size	Normal size	
		SZB0 \ SZB1	0	1										
0	Normal size	Double size												
1	Triple size	Normal size												
1														
1	SZ91	0	<table border="1"> <tr> <td>SZ91 \ SZ90</td> <td>0</td> <td>1</td> </tr> <tr> <td>0</td> <td>Normal size</td> <td>Double size</td> </tr> <tr> <td>1</td> <td>Triple size</td> <td>Normal size</td> </tr> </table>		SZ91 \ SZ90	0	1	0	Normal size	Double size	1	Triple size	Normal size	The character size for the ninth line.
		SZ91 \ SZ90	0	1										
0	Normal size	Double size												
1	Triple size	Normal size												
1														
0	SZ90	0	<table border="1"> <tr> <td>SZ90 \ SZ91</td> <td>0</td> <td>1</td> </tr> <tr> <td>0</td> <td>Normal size</td> <td>Double size</td> </tr> <tr> <td>1</td> <td>Triple size</td> <td>Normal size</td> </tr> </table>		SZ90 \ SZ91	0	1	0	Normal size	Double size	1	Triple size	Normal size	
		SZ90 \ SZ91	0	1										
0	Normal size	Double size												
1	Triple size	Normal size												
1														

Second byte

DA0 to DA7	Register name	Register content			Note
		State	Function		
7	—	0	Second byte identification code		
6	—	0			
5	HP5 (MSB)	0	The horizontal display start position is given by $HS = Tc \times \left(\sum_{n=0}^5 2^n HP_n \right)$ where Tc is the period of the OSCIN and OSCOUT oscillator in operating mode.		The six bits HP0 to HP5 specify the vertical display start position. The weight of the lsb is 1 x Tc.
		1			
4	HP4	0			
		1			
3	HP3	0			
		1			
2	HP2	0			
		1			
1	HP1	0			
		1			
0	HP0 (LSB)	0			
		1			

Note: When the chip is reset by the RST pin, the register states (bits) are all cleared to 0.

⑤ COMMAND4: Display Control Setting Command 1

First byte

DA0 to DA7	Register name	Register content			Note
		State	Function		
7	—	1	The command 4 identification code: sets display control parameters.		
6	—	1			
5	—	0			
4	—	0			
3	RST _{sys}	0			This reset occurs when the CS pin goes low, and the reset state cleared when the CS pin goes high.
		1	Resets all registers. (Clears all registers to 0.)		
2	RAM _{ERS}	0			The RAM erase function requires at least 500 μs. It is executed on DSPOFF.
		1	Erases display RAM. (Sets display RAM to FF (hexadecimal).)		
1	OSC _{STP}	0	Continues crystal oscillator operation.		Only valid with character display off if external synchronization is used.
		1	Stops the crystal oscillator.		
0	RND _{SEL}	0	Turns off rounding.		Only valid for double and triple size characters.
		1	Turns on rounding.		

LC74763, 74763M

Second byte

DA0 to DA7	Register name	Register content			Note																	
		State	Function																			
7	—	0	Second byte identification code																			
6	INT/NON	0	Interlaced		Switches between interlaced and non-interlaced display.																	
		1	Non-interlaced																			
5	BLK1	0	<table border="1"> <tr> <td></td> <td>BLK0</td> <td>0</td> <td>1</td> </tr> <tr> <td>BLK1</td> <td></td> <td>0</td> <td>1</td> </tr> <tr> <td>0</td> <td></td> <td>Blanking off</td> <td>Character size blanking</td> </tr> <tr> <td>1</td> <td></td> <td>Frame size blanking</td> <td>Total area blanking</td> </tr> </table>			BLK0	0	1	BLK1		0	1	0		Blanking off	Character size blanking	1		Frame size blanking	Total area blanking	Changes the blanking size.	
					BLK0	0	1															
BLK1		0	1																			
0		Blanking off	Character size blanking																			
1		Frame size blanking	Total area blanking																			
1																						
4	BLK0	0																				
		1																				
3	BK1	0	Flashing period about 0.5 s		Sets the flashing period.																	
		1	Flashing period about 1 s																			
2	ATS	0	Highlight function		Selects at2.																	
		1	Flashing function																			
1	—	0																				
0	DSPON	0	Character display off		Turns character output on and off.																	
		1	Character display on																			

Note: When the chip is reset by the RST pin, the register states (bits) are all cleared to 0.

⑥ COMMAND5: Display Control Setting Command 2

First byte

DA0 to DA7	Register name	Register content			Note																																																				
		State	Function																																																						
7	—	1																																																							
6	—	1																																																							
5	—	0	The command 5 identification code: sets display control parameters.																																																						
4	—	1																																																							
3	PH2	0	<table border="1"> <tr> <td></td> <td></td> <td></td> <td colspan="2">Background color (phase)</td> </tr> <tr> <td></td> <td></td> <td></td> <td>NTSC</td> <td>PAL</td> </tr> <tr> <td>0</td> <td>0</td> <td>0</td> <td>$\pi/2$</td> <td>$\pm\pi/2$</td> </tr> <tr> <td>0</td> <td>0</td> <td>1</td> <td>In phase</td> <td>In phase</td> </tr> <tr> <td>0</td> <td>1</td> <td>0</td> <td>$3\pi/2$</td> <td>$\mp\pi/2$</td> </tr> <tr> <td>1</td> <td>0</td> <td>1</td> <td>π</td> <td>$\pm\pi$</td> </tr> <tr> <td>1</td> <td>0</td> <td>0</td> <td>$3\pi/4$</td> <td>$\pm 3\pi/4$</td> </tr> <tr> <td>1</td> <td>0</td> <td>1</td> <td>$\pi/4$</td> <td>$\pm\pi/4$</td> </tr> <tr> <td>1</td> <td>1</td> <td>0</td> <td>$7\pi/4$</td> <td>$\mp\pi/4$</td> </tr> <tr> <td>1</td> <td>1</td> <td>1</td> <td>$5\pi/4$</td> <td>$\mp 3\pi/4$</td> </tr> </table>						Background color (phase)					NTSC	PAL	0	0	0	$\pi/2$	$\pm\pi/2$	0	0	1	In phase	In phase	0	1	0	$3\pi/2$	$\mp\pi/2$	1	0	1	π	$\pm\pi$	1	0	0	$3\pi/4$	$\pm 3\pi/4$	1	0	1	$\pi/4$	$\pm\pi/4$	1	1	0	$7\pi/4$	$\mp\pi/4$	1	1	1	$5\pi/4$	$\mp 3\pi/4$	Sets the phase of the background color for color burst.sz	
								Background color (phase)																																																	
			NTSC	PAL																																																					
0	0	0	$\pi/2$	$\pm\pi/2$																																																					
0	0	1	In phase	In phase																																																					
0	1	0	$3\pi/2$	$\mp\pi/2$																																																					
1	0	1	π	$\pm\pi$																																																					
1	0	0	$3\pi/4$	$\pm 3\pi/4$																																																					
1	0	1	$\pi/4$	$\pm\pi/4$																																																					
1	1	0	$7\pi/4$	$\mp\pi/4$																																																					
1	1	1	$5\pi/4$	$\mp 3\pi/4$																																																					
1																																																									
2	PH1	0																																																							
		1																																																							
1	PH0	0																																																							
		1																																																							
0	INT/EXT	0	External synchronization mode		Switches between internal and external synchronization.																																																				
		1	Internal synchronization mode																																																						

Second byte

DA0 to DA7	Register name	Register content				Note	
		State	Function				
7	—	0	Second byte identification code				
6	TST	0	Normal operation			Test mode should not be used. This bit should always be zero.	
		1	Test mode				
5	CHAL	0	Sets the character intensity level to about 85 IRE (bright white).			Switches the character intensity level.	
		1	Sets the character intensity level to about 72 IRE (white with a touch of grey).				
4	BKL	0	Sets the blanking intensity level to about 3 IRE (a deep black as a frame level).			Switches the blanking intensity level.	
		1	Sets the blanking intensity level to about 13 IRE (a dark grey as a frame level).				
3	RSL1	0	RSL1	RSL0	Intensity level	Amplitude	Switches the background intensity level.
		1	0	0	About 15 IRE	About 60 IRE	
2	RSL0	0	0	1	About 30 IRE	About 60 IRE	
		1	1	0	About 45 IRE	About 60 IRE	
1	CV _{outmt}	0	Normal CV _{out} output				
		1	CV _{out} pedestal level output				
0	XTAL _{sel}	0	Selects XTAL1			Switches the oscillator circuit	
		1	Selects XTAL2				

Note: When the chip is reset by the \overline{RST} pin, the register states (bits) are all cleared to 0.

⑦ COMMAND6: Display Control Setting Command 3

First byte

DA0 to DA7	Register name	Register content				Note
		State	Function			
7	—	1	The command 6 identification code: sets display control parameters.			
6	—	1				
5	—	1				
4	—	0				
3	MOD3	0	Sets Fsc to 3.58 MHz.			The logical or of this bit and the Fsc switching input pin (pin 14) is used.
		1	Sets Fsc to 4.43 MHz.			
2	MOD2	0	Sets the color mode to NTSC.			The logical or of this bit and the color mode switching input pin (pin 13) is used.
		1	Sets the color mode to PAL.			
1	MOD1	0	Sets the number of scan lines to 525 lines.			The logical or of this bit and the scan line count switching input pin (pin 12) is used.
		1	Sets the number of scan lines to 625 lines.			
0	MOD0	0	Sets the mode to a mode other than SECAM.			The logical or of this bit and the mode switching input pin (pin 11) is used.
		1	Sets the mode to SECAM mode.			

LC74763, 74763M

Second byte

DA0 to DA7	Register name	Register content			Note	
		State	Function			
7	—	0	Second byte identification code			
6	HALF INT	0	Normal mode			
		1	Half internal synchronous mode			
5	P14OUT SEL	0	Half tone output		Selects P14 (3.58/4.43) output.	
		1	High output in internal synchronous mode			
4	SECAM SEL	0	In SECAM mode, only the character frame area is on.		Selects the CVCR "on" period.	
		1	In SECAM mode, the entire character display area is on.			
3	IOS	0	Sets the mode setting pin to be an input pin.		Switches the input/output direction of the mode setting pins.	
		1	Sets the mode setting pin to be an output pin.			
2	BCOL1	0	BCOL1	BCOL0	Background color	Determines whether a background color is displayed. (Only valid in internal synchronization mode.)
		1	0	0	Background color displayed	
1	0		1	No background color (about 13 IRE)		
	1	1	0	No background color (about 23 IRE)		
1		1	1	CV _{outm2} (CSYNC)		
	0	CBOFF	0	Outputs a color burst signal.		
1			Stops the output of color burst signals.			

Note: When the chip is reset by the \overline{RST} pin, the register states (bits) are all cleared to 0.

⑧ COMMAND70: Display Control Setting Command 4

First byte

DA0 to DA7	Register name	Register content			Note
		State	Function		
7	—	1	The command 7 identification code: sets display control parameters.		
6	—	1			
5	—	1			
4	—	1			
3	—	0	Expansion command 0 identification code		
2	—	0			
1	—	0			
0	LINS	0	Selects the lower 6 bits (bits 0 to 5)		Selects the upper or lower six bits when half tone output line mode is specified.
		1	Selects the upper 6 bits (bits 6 to B)		

Second byte

DA0 to DA7	Register name	Register content			Note
		State	Function		
7	—	0	Second byte identification code		
6	VCO SELECT1	0	VCO frequency is 14.12 MHz		Selects VCO oscillation frequency.
		1	VCO frequency is 7.07 MHz		
5	LINS	0	Turns off (low) sixth line half tone output.		Used for the line 12 setting when LINS is high.
		1	Turns on (high) sixth line half tone output.		
4	LIN4	0	Turns off (low) fifth line half tone output.		Used for the line 11 setting when LINS is high.
		1	Turns on (high) fifth line half tone output.		
3	LIN3	0	Turns off (low) fourth line half tone output.		Used for the line 10 setting when LINS is high.
		1	Turns on (high) fourth line half tone output.		
2	LIN2	0	Turns off (low) third line half tone output.		Used for the line 9 setting when LINS is high.
		1	Turns on (high) third line half tone output.		
1	LIN1	0	Turns off (low) second line half tone output.		Used for the line 8 setting when LINS is high.
		1	Turns on (high) second line half tone output.		
0	LIN0	0	Turns off (low) first line half tone output.		Used for the line 7 setting when LINS is high.
		1	Turns on (high) first line half tone output.		

Note: When the chip is reset by the \overline{RST} pin, the register states (bits) are all cleared to 0.

⑨ COMMAND71: Display Control Setting Command 5

First byte

DA0 to DA7	Register name	Register content		Note
		State	Function	
7	—	1	The command 7 identification code: sets display control parameters	
6	—	1		
5	—	1		
4	—	1		
3	—	0	Expansion command 1 identification code	
2	—	1		
1	—	0		
0	LINS	0	Selects lower 6 bits (0 to 5).	Selects lower or upper 6 bits for half-tone output line setting.
		1	Selects upper 6 bits (6 to B).	

Second byte

DA0 to DA7	Register name	Register content		Note
		State	Function	
7	—	0	Second byte identification bit	
6	EGMODE 2SELECT	0	Normal display	
		1	Applies frame to inverted characters also.	
5	PORTSET SELECT2	0	Sets port output data	
		1	Sets port (output switching)	
4	PORTSET SELECT1	0	Sets port output data	
		1	Sets port (output switching)	
3	VMN SEL	0	Normal V signal	
		1	VMASK signal	
2	VINPsel	0	Normal I/O	
		1	V is input from P11.	
1	VNPsel	0	V rise detection	Selects V detection polarity.
		1	V fall detection	
0	VSEPsel	0	VSEP is about 9.3 μ s.	Selects V separation time.
		1	VSEP is about 18.6 μ s.	

Note: When the chip is reset by the $\overline{\text{RST}}$ pin, the register states (bits) are all cleared to 0.

⑩ COMMAND72: Display Control Setting Command 6

First byte

DA0 to DA7	Register name	Register content		Note
		State	Function	
7	—	1	The command 7 identification code: sets display control parameters	
6	—	1		
5	—	1		
4	—	1		
3	—	1	Expansion command 2 identification code	
2	—	0		
1	—	0		
0	LINS	0	Selects lower 6 bits (0 to 5).	Selects lower or upper 6 bits for half-tone output line setting.
		1	Selects upper 6 bits (6 to B).	

Second byte

DA0 to DA7	Register name	Register content		Note
		State	Function	
7	—	0	Second byte identification bit	
6	—	0		
5	—	0		
4	—	0		
3	MOD3 SEL	0	Normal MOD3 (P14) output (PS1 = 1)	Specifies port output data when PS1 = 0.
		1	Specifies MOD3 general port output	
2	MOD2 SEL	0	Normal MOD2 (P13) output (PS1 = 1)	Specifies port output data when PS1 = 0.
		1	Specifies MOD2 general port output	
1	MOD1 SEL	0	Normal MOD1 (P12) output (PS1 = 1)	Specifies port output data when PS1 = 0.
		1	Specifies MOD1 general port output	
0	MOD0 SEL	0	Normal MOD0 (P11) output (PS1 = 1)	Specifies port output data when PS1 = 0.
		1	Specifies MOD0 general port output	

Note: When the chip is reset by the RST pin, the register states (bits) are all cleared to 0.

Ⓛ COMMAND73: Display Control Setting Command 7

First byte

DA0 to DA7	Register name	Register content		Note
		State	Function	
7	—	1	The command 7 identification code: sets display control parameters	
6	—	1		
5	—	1		
4	—	1		
3	—	1	Expansion command 3 identification code	
2	—	1		
1	—	0		
0	LINS	0	Selects lower 6 bits (0 to 5).	Selects lower or upper 6 bits for half tone output line setting.
		1	Selects upper 6 bits (6 to B).	

Second byte

DA0 to DA7	Register name	Register content		Note
		State	Function	
7	—	0	Second byte identification bit	
6	—	0		
5	—	0		
4	—	0		
3	VCP SELECT2	0	No feedback resistance	Specifies VCO oscillator feedback resistance connection
		1	Feedback resistance	
2	SDETOUT SEL	0	Normal SOUT (P29) output (PS2 = 1)	Specifies port output data when PS2 = 0.
		1	Specifies SOUT general port output	
1	VOUT SEL	0	Normal VOUT (P7) output (PS2 = 1)	Specifies port output data when PS2 = 0.
		1	Specifies VOUT general port output	
0	HOUT SEL	0	Normal HOUT (P4) output (PS2 = 1)	Specifies port output data when PS2 = 0.
		1	Specifies HOUT general port output	

Note: When the chip is reset by the RST pin, the register states (bits) are all cleared to 0.

Display Configuration

The display consists of 12 rows of 24 characters each. Up to 288 characters can be displayed unless enlarged characters are displayed. Display memory addresses are expressed as a row address in the range 0 to B (hexadecimal) and a column address in the range 0 to 17 (hexadecimal).

Display Configuration and Display Memory Addresses

24 characters by 12 rows

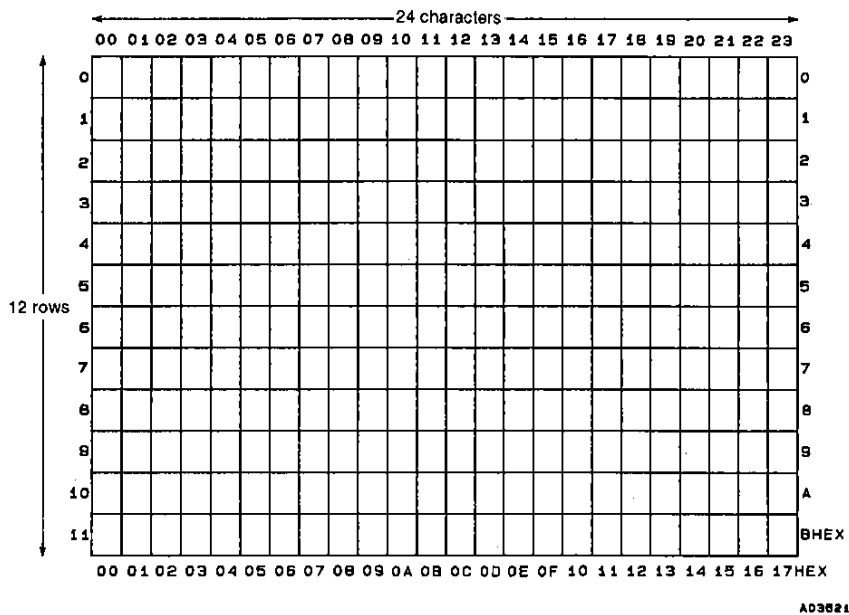

Composite Video Signal Output Levels (Internally generated levels) Metal Option

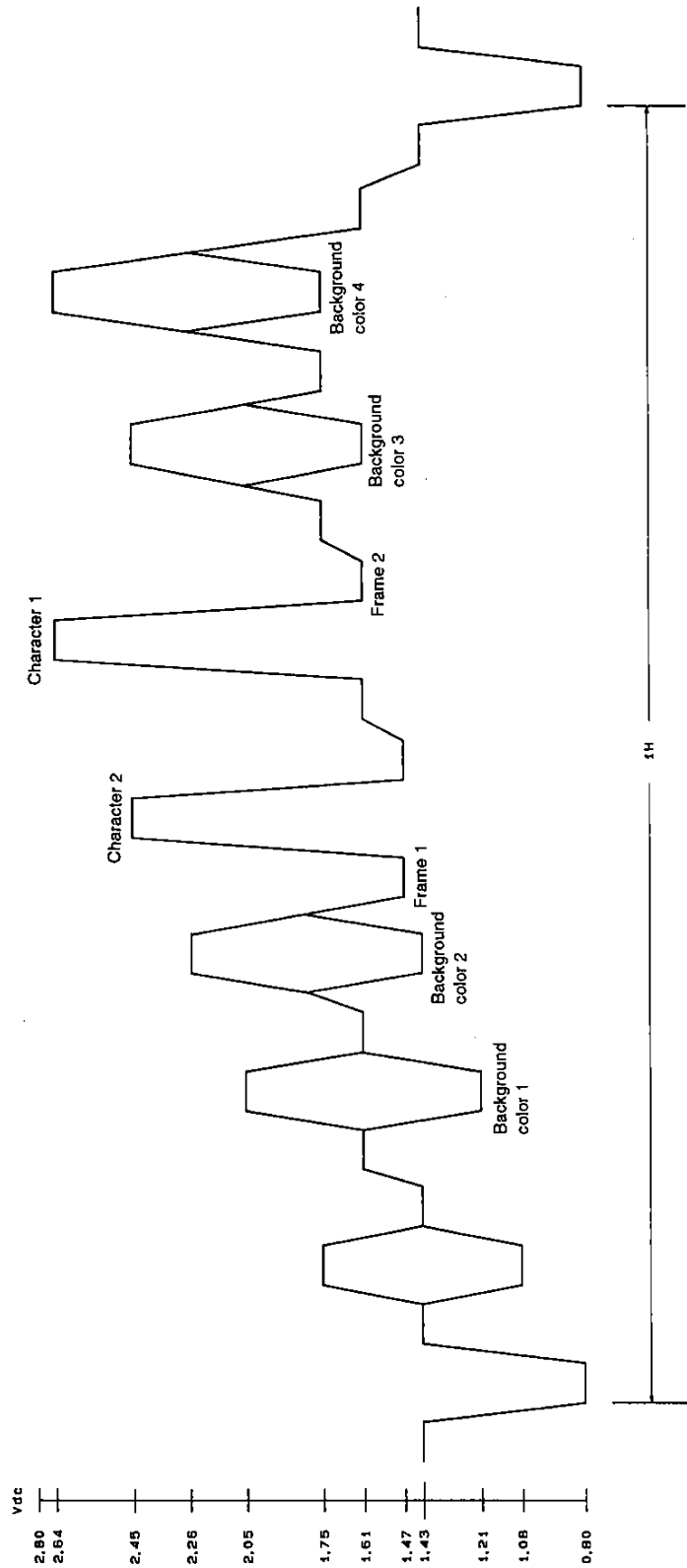

A03522

Output level	Output voltage (VDC)
Frame level 1	1.465
Pedestal level	1.429
Background low level 1	1.212
Burst low level	1.080
Sync level	0.800

Output level	Output voltage (VDC)
Character level 1	2.638
Character level 2	2.449
Background high level 2	2.262
Background high level 1	2.047
Burst high level	1.747
Frame level 2	1.610

Composite Video Signal Output Levels (internally generated levels) Metal Option

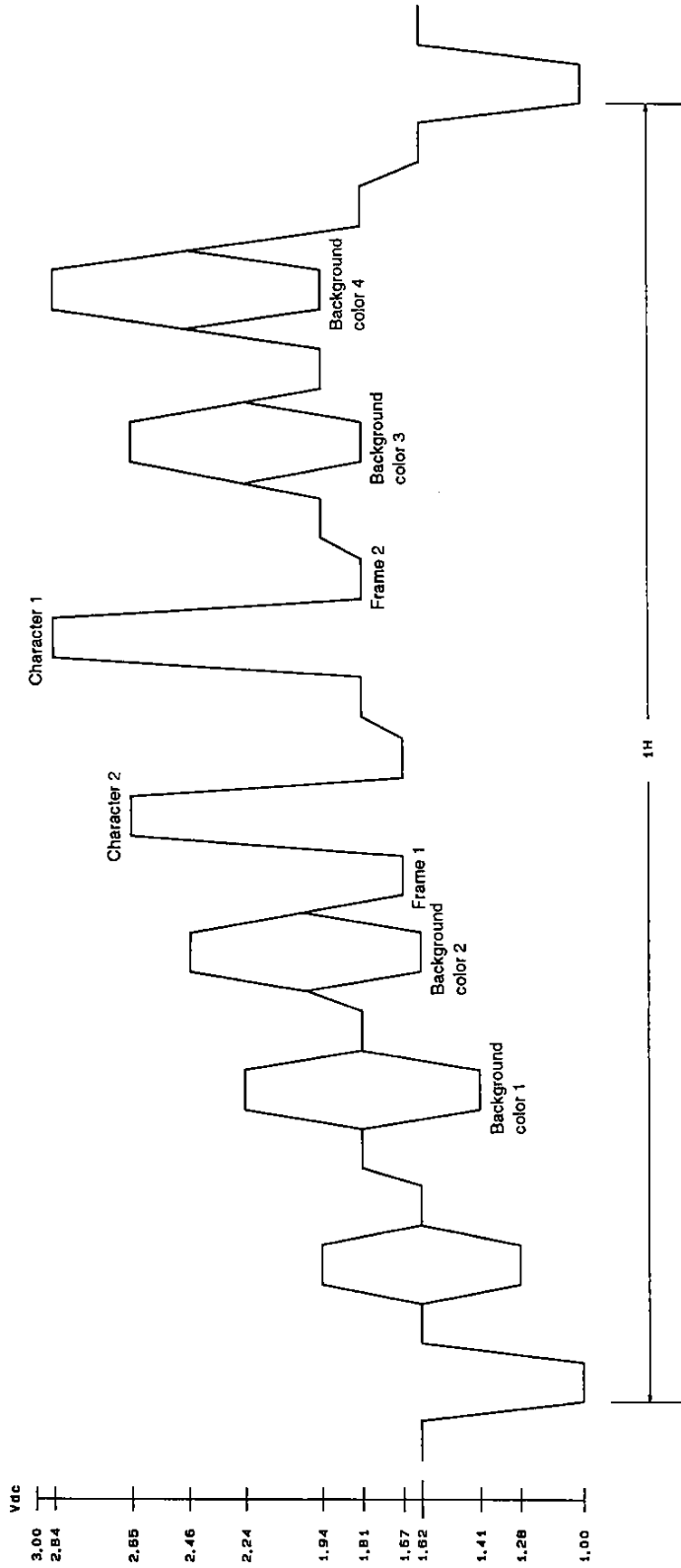

A03923

Output level	Output voltage (VDC)
Frame level 1	1.665
Pedestal level	1.624
Background low level 1	1.407
Burst low level	1.275
Sync level	1.000

Output level	Output voltage (VDC)
Character level 1	2.841
Character level 2	2.652
Background high level 2	2.456
Background high level 1	2.242
Burst high level	1.943
Frame level 2	1.811

Composite Video Signal Output Levels (Internally generated levels) Metal Option

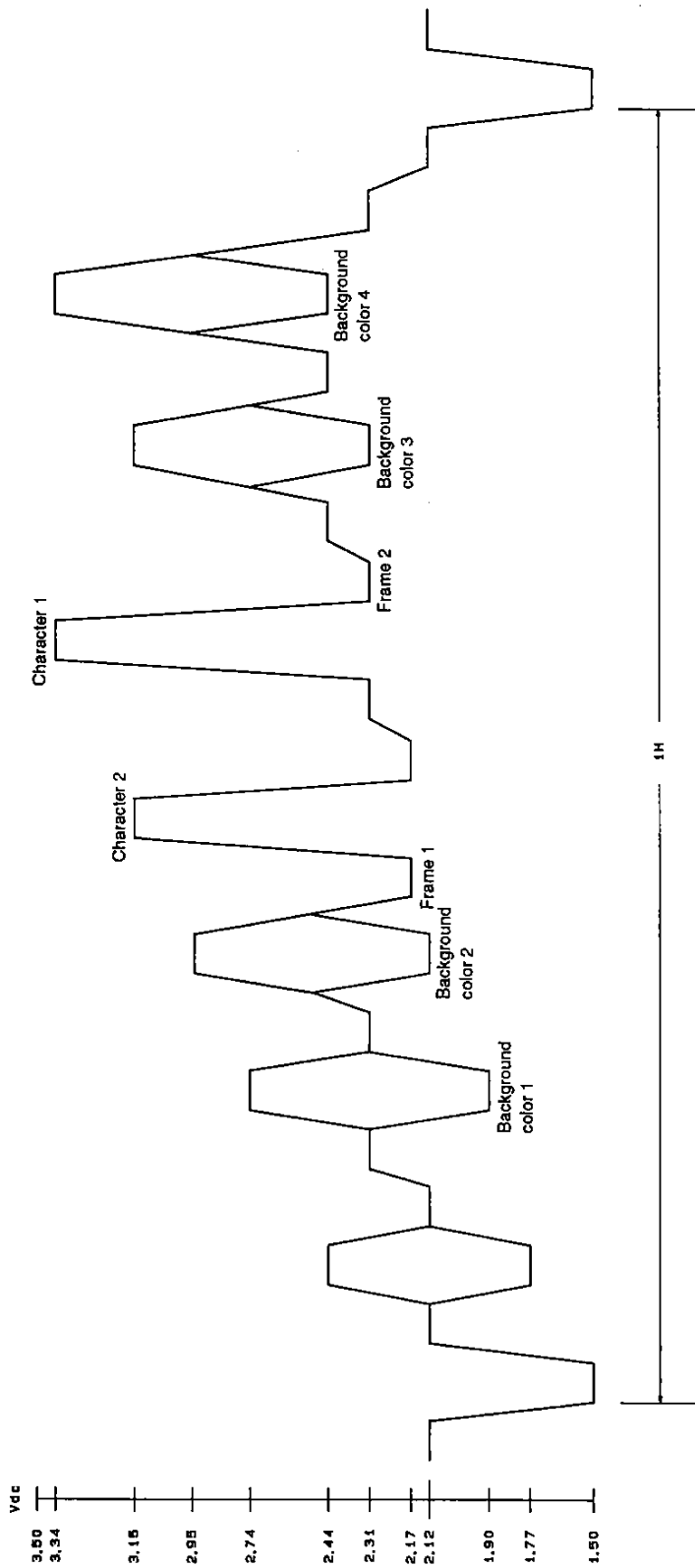

Output level	Output voltage (VDC)
Frame level 1	2.166
Pedestal level	2.118
Background low level 1	1.902
Burst low level	1.770
Sync level	1.500

Output level	Output voltage (VDC)
Character level 1	3.342
Character level 2	3.153
Background high level 2	2.950
Background high level 1	2.735
Burst high level	2.436
Frame level 2	2.312

Application Circuit Diagram

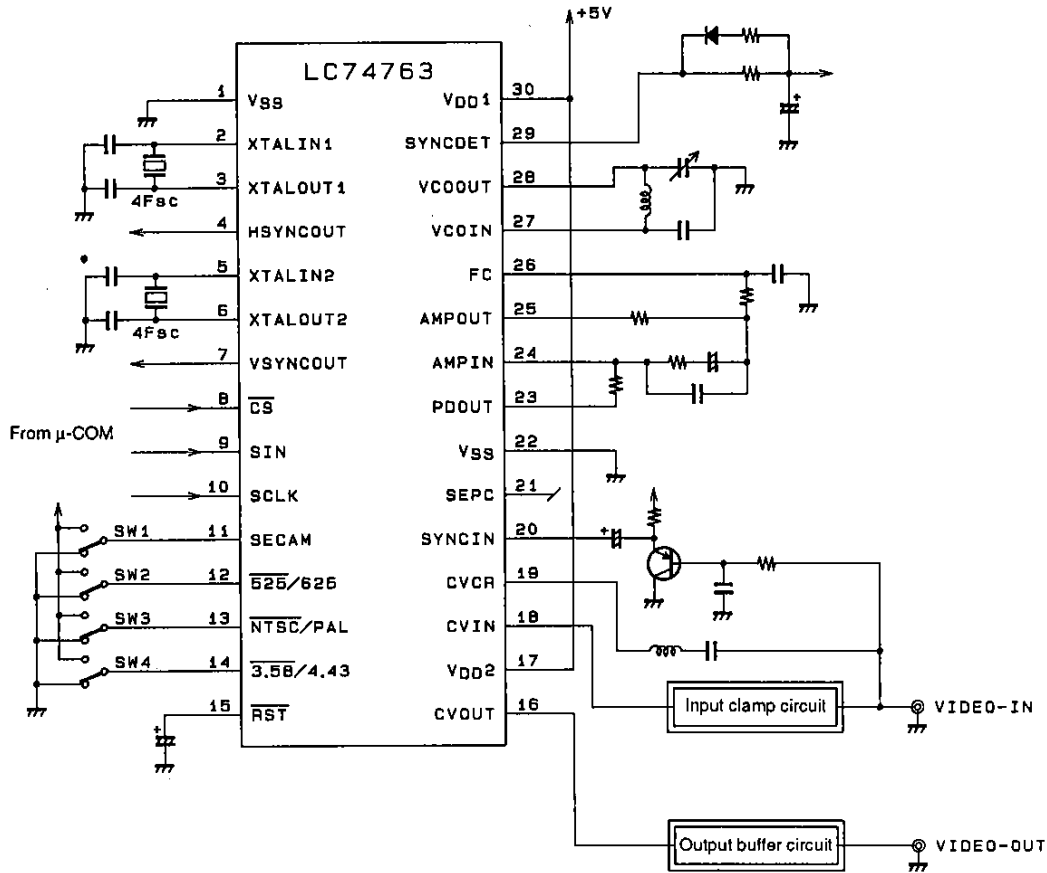

A03525

Signal format	4 Fsc (MHz)
NTSC	3.579545 × 4
PAL	4.433618 × 4
SECAM	4.433618 × 4
PAL-M	3.575611 × 4
PAL-N	3.582056 × 4
NTSC4.43	4.433618 × 4
PAL60	4.433618 × 4

Signal format	SW1	SW2	SW3	SW4
NTSC	0	0	0	0
PAL	0	1	1	1
SECAM	1	(1)	(1)	(1)
PAL-M	0	0	1	0
PAL-N	0	1	1	0
NTSC4.43	0	0	0	1
PAL60	0	0	1	1

Note: Fix SW1 to SW4 to 0 when setting a mode by command.

■ No products described or contained herein are intended for use in surgical implants, life-support systems, aerospace equipment, nuclear power control systems, vehicles, disaster/crime-prevention equipment and the like, the failure of which may directly or indirectly cause injury, death or property loss.

■ Anyone purchasing any products described or contained herein for an above-mentioned use shall:

- ① Accept full responsibility and indemnify and defend SANYO ELECTRIC CO., LTD., its affiliates, subsidiaries and distributors and all their officers and employees, jointly and severally, against any and all claims and litigation and all damages, cost and expenses associated with such use;
- ② Not impose any responsibility for any fault or negligence which may be cited in any such claim or litigation on SANYO ELECTRIC CO., LTD., its affiliates, subsidiaries and distributors or any of their officers and employees jointly or severally.

■ Information (including circuit diagrams and circuit parameters) herein is for example only; it is not guaranteed for volume production. SANYO believes information herein is accurate and reliable, but no guarantees are made or implied regarding its use or any infringements of intellectual property rights or other rights of third parties.

This catalog provides information as of December, 1996. Specifications and information herein are subject to change without notice.