

BBS (bass boost system) for radio cassette players

BA3870

The BA3870 is a bass boost audio IC for radio cassette players. BBS adjusts the base boost to a level appropriate for the volume, achieving a rich sound without distortion. Frequency characteristics can be set externally, enabling system design to meet the needs of the application.

●Applications

Radio cassette players

●Features

- 1) Adjustment of the base boost to a level appropriate for the volume through BBS.
- 2) Maximum bass boost level can be set externally. (20dB recommended)
- 3) Treble boost circuit (constant at 4dB) included on-chip to preserve overall balance.
- 4) BBS on/off “pop” sound almost nonexistent.

●Absolute maximum ratings (Ta = 25°C)

Parameter	Symbol	Limits	Unit
Power supply voltage	V _{CC}	9.0	V
Power dissipation	P _d	600*	mW
Operating temperature	T _{opr}	-25~+75	°C
Storage temperature	T _{stg}	-55~+125	°C

* Reduced by 6.0mW for each increase in Ta of 1°C over 25°C.

●Recommended operating conditions (Ta = 25°C)

Parameter	Symbol	Limits	Unit
Power supply voltage	V _{CC}	3.0~7.0	V

●Block diagram

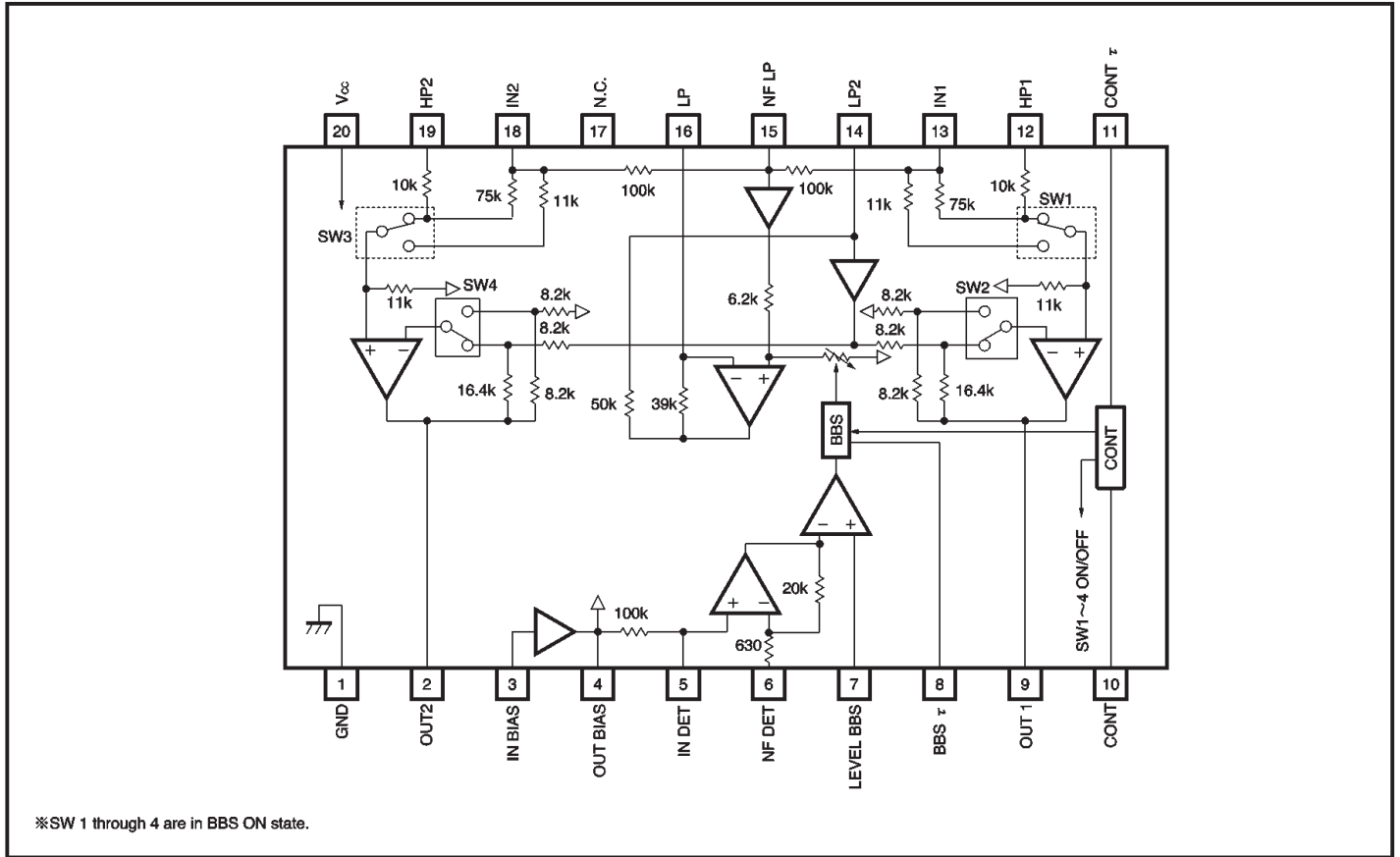

●Pin descriptions

Pin No.	Pin name	Function
1	GND	Substrate ground
2	OUT2	Output 2
3	BIAS IN	Bias amplifier input
4	BIAS OUT	Bias amplifier output
5	DET IN	Detection amplifier positive input
6	DET NF	Detection amplifier negative input
7	BBS LEVEL	BBS level setting
8	BBS τ	BBS time constant setting
9	OUT1	Output 1
10	CONT	BBS on/off switch
11	CONT τ	BBS time constant setting
12	HP 1	High-range input
13	IN 1	Input 1
14	LP 2	Low-range amplifier output
15	LP 1	Low range amplifier positive input
16	LP NF	Low range amplifier negative input
17	N.C.	Not connected to inside of IC
18	IN 2	Input 2
19	HP 2	High-range input 2
20	V _{cc}	Voltage supply

● Input/output circuits

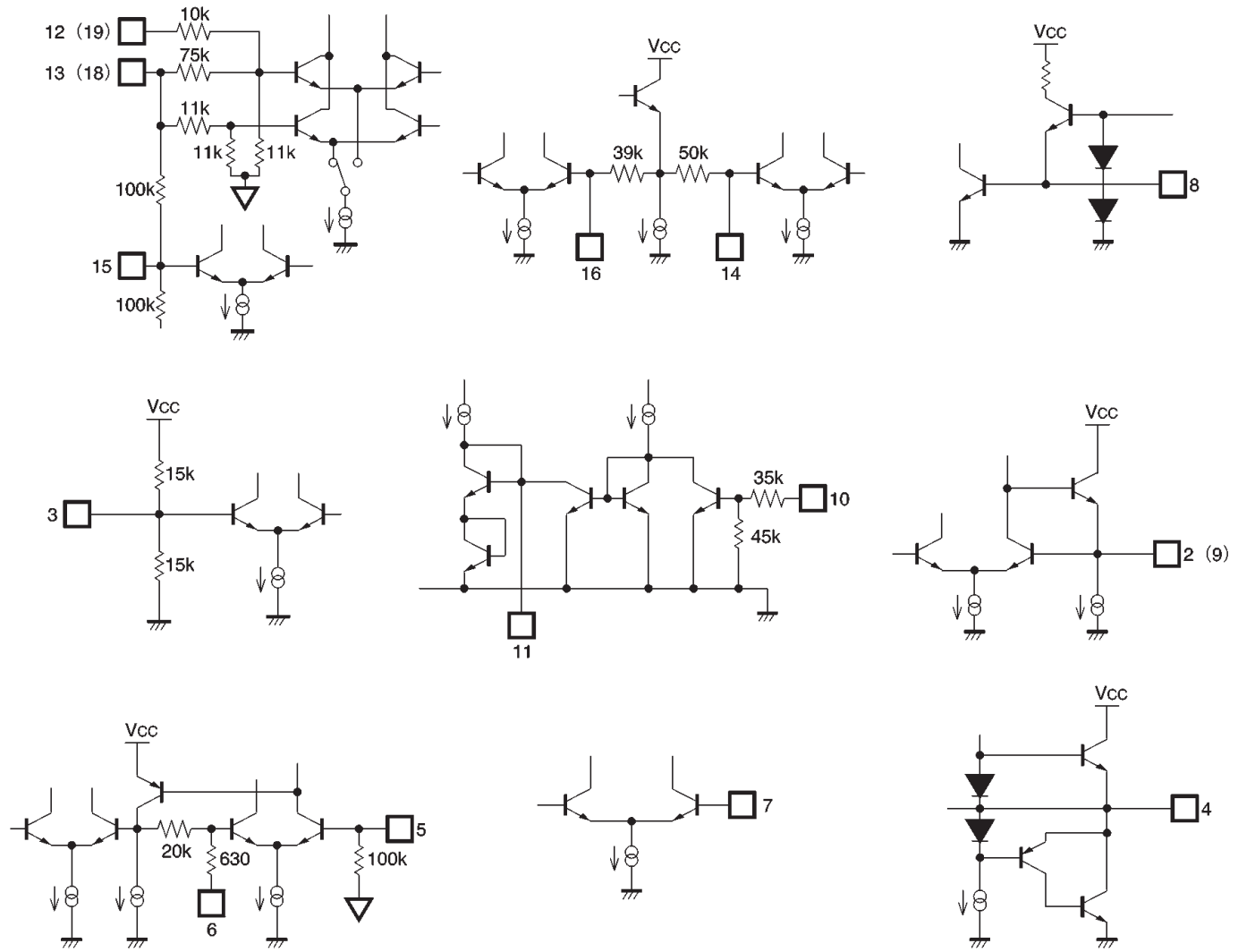

● Electrical characteristics (unless otherwise noted, $T_a = 25^\circ\text{C}$, $V_{CC} = 5.0\text{V}$ and $f = 1\text{kHz}$)

Parameter	Symbol	Min.	Typ.	Max.	Unit	Condition
Quiescent current	I_q	—	5.0	8.0	mA	BBS ON
Voltage gain	G_v	-2.5	0	2.5	dB	BBS OFF
Total harmonic distortion	THD	—	0.05	0.2	%	BBS ON, $V_o=20\text{dBm}$, DET IN= $0V_{\text{rms}}$
Output noise voltage	V_{NO}	—	-90	-84	dBm	BBS ON, DIN AUDIO, $R_g=2.2\text{k}\Omega$
Input resistance	R_{IN}	9	13.5	18	$\text{k}\Omega$	—
Channel separation	CS	—	-58	-53	dB	BBS OFF, $V_o=0\text{dBm}$, $R_g=2.2\text{k}\Omega$
Bass boost	BB	17	20	23	dB	$V_{IN}=-50\text{dBm}$, $f=100\text{Hz}$, DET IN= $0V_{\text{rms}}$
Treble boost	TB	2.0	4.0	6.0	dB	$V_{IN}=-50\text{dBm}$, $f=10\text{kHz}$
Ripple rejection	RR	23	28	—	dB	BBS ON, $V_{RR}=-30\text{dBm}$, $f_{RR}=100\text{Hz}$, $R_g=0\Omega$
HIGH threshold voltage	V_{TH}	—	1.1	1.4	V	—
Maximum output voltage	V_{OM}	0.7	1.2	—	V_{rms}	BBS OFF, THD=1%, $R_L=10\text{k}\Omega$

● Measurement circuit

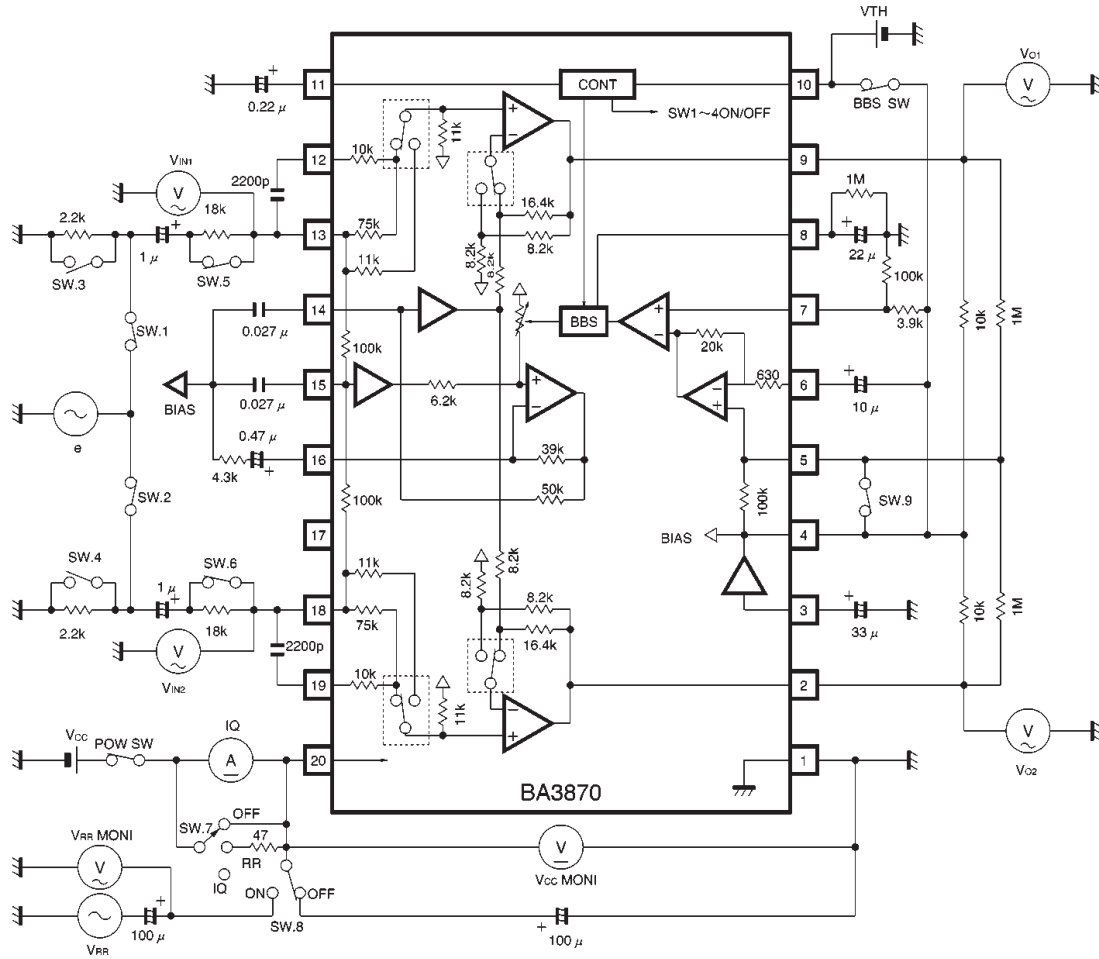

Fig.1

●Circuit Operation

(1) Overview of BBS

BBS is a system which boosts the low end of the audible frequency range and at the same time linearly controls the amount of boost according to the volume to produce a rich sound without distortion through small diameter speakers. It also adjusts the gain of the high-frequency range to attain a balanced sound with natural volume.

(2) Operation of BBS

1) BBS on

The signal system when BBS is on is shown in Fig. 2.

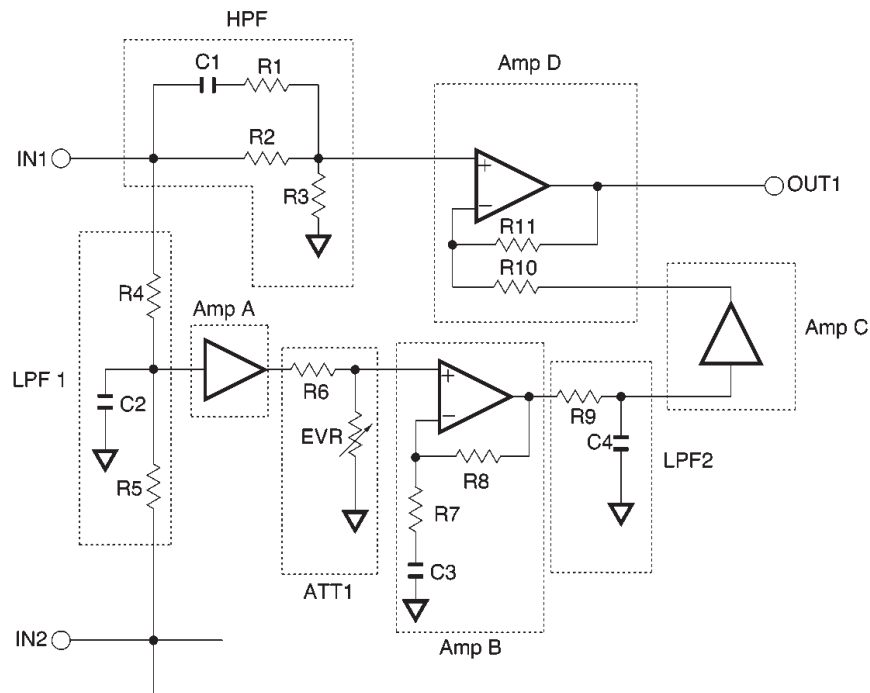
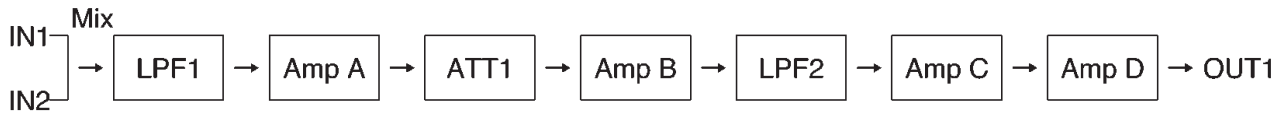

Fig. 2 Signal system when BBS is on.

1. Low range signal system

The transmission of low range signals in Fig. 2 is as shown below.



The frequency characteristics of each block are as shown in Fig. 3, and the gain and cutoff frequency of each are given by the following equations.

$$\text{Cutoff frequency of LPF1} : f_{CL1} = \frac{1}{2\pi \cdot (R_4/R_5) \cdot C_2} \quad (\text{Hz})$$

$$\text{Attenuation of LPF1} : G_{LP1} = 20\log \frac{R_5}{R_4 + R_5} \quad (\text{dB})$$

$$\text{Gain of Amp A} : G_A = 0 \quad (\text{dB})$$

$$\text{Attenuation of ATT1} : G_{ATT1} = 20\log \frac{\text{EVR}}{R_6 + \text{EV}} \quad (\text{dB})$$

$$\text{Gain of Amp B} : G_B = 20\log \frac{R_7 + R_8}{R_7} \quad (\text{dB})$$

$$\text{Cutoff frequency of Amp B: } f_{CL3} = \frac{1}{2\pi \cdot R_7 \cdot C_3} \quad (\text{Hz})$$

$$\text{Cutoff frequency of LPF2: } f_{CL2} = \frac{1}{2\pi \cdot R_9 \cdot C_4} \quad (\text{Hz})$$

$$\text{Gain of Amp C} : G_C = 0 \quad (\text{dB})$$

$$\text{Gain of Amp D} : G_{DL} = 20\log \frac{R_{11}}{R_{10}} \quad (\text{dB})$$

Here, $R_4 = R_5 = 2R_9$ and $C_2 = C_4$, thus

$$f_{CL1} = f_{CL2}$$

and the total frequency shows a -12dB/OCT bass boost as indicated in Fig. 4.

Also, as $R_{11} = 2R_{10}$,

$$G_{LP1} + G_{DL} = -6 + 6 = 0 \quad (\text{dB})$$

and thus the total gain during EVR Max. is

$$G_{L \text{ Max.}} = G_{LP1} + G_A + G_B + G_C + G_{DL} = G_B \quad (\text{dB})$$

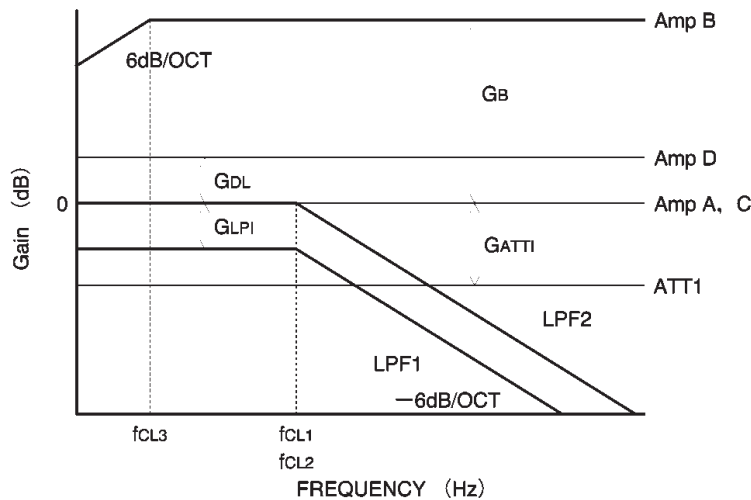

Fig. 3 Frequency characteristics of each block of low-range signal system

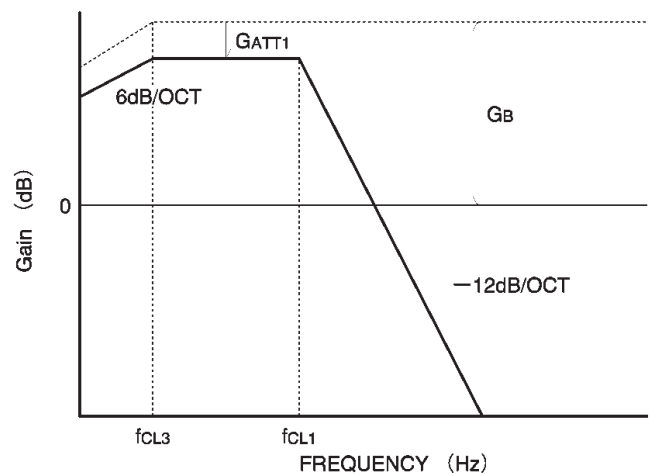
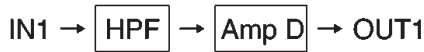

Fig. 4 Total frequency characteristics of low-range signal system

2. High-range signal system

The transmission of high frequency signals in Fig. 2 is as shown below.



The frequency characteristics of each block are shown in Fig. 5, and the gain and cutoff frequency of each are given by the following equations.

Cutoff frequency 1 of HPF: $f_{CH1} = \frac{1}{2\pi \cdot (R_1 + R_2) C_1}$ (Hz)

Cutoff frequency 2 of HPF: $f_{CH2} = \frac{(R_2 + R_3)}{2\pi \cdot (R_1 R_2 + R_2 R_3 + R_1 R_3) C_1}$ (Hz)

Attenuation of HPF in frequency range $f < f_{CH1}$: $G_{HP1} = 20\log \frac{R_3}{R_2 + R_3}$ (dB)

Attenuation of HPF in frequency range $f_{CH2} < f$: $G_{HP2} = 20\log \frac{R_3}{R_1 // R_2 + R_3}$ (dB)

Gain of Amp D : $G_{DH} = 20\log \frac{R_{10} + R_{11}}{R_{10}}$ (dB)

The total frequency characteristics show a +6dB/OCT treble boost as shown in Fig. 6.

Also, $R_{11} = 2R_{10}$, thus

$G_{DH} = +9.5$ (dB)

and the total gain G_{H1} in the $f < f_{CH1}$ frequency range is

$G_{H1} = G_{HP1} + G_{DH}$
 $= G_{HP1} + 9.5$ (dB)

The total gain G_{H2} in the $f_{CH2} < f$ frequency range is

$G_{H2} = G_{HP2} + G_{DH}$
 $= G_{HP2} + 9.5$ (dB)

3. Combination of frequency characteristics

By combining the low-range characteristics (Fig. 4) and the high-range characteristics (Fig. 6), ideal BBS characteristics can be obtained as shown in Fig. 7.

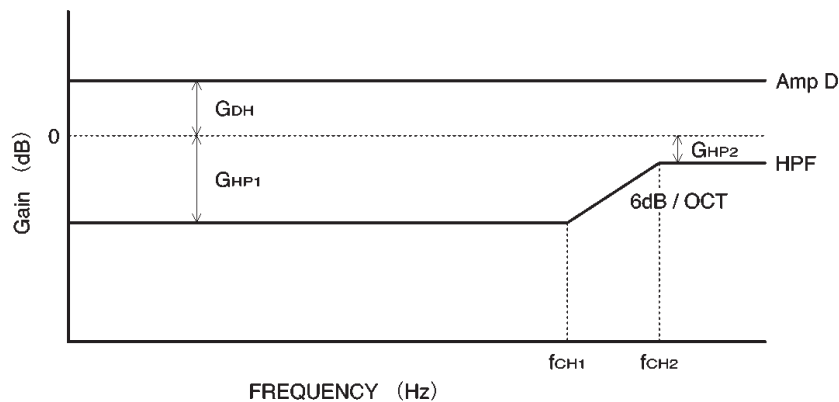

Fig. 5 Frequency characteristics of each block of high-range signal system

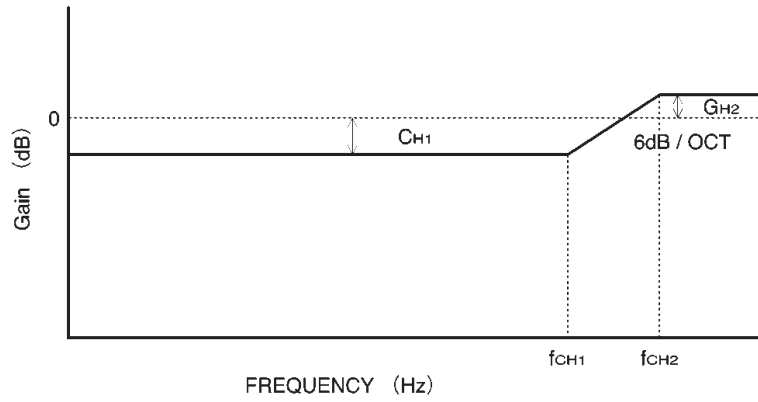

Fig. 6 Total frequency characteristics of high-range signal system

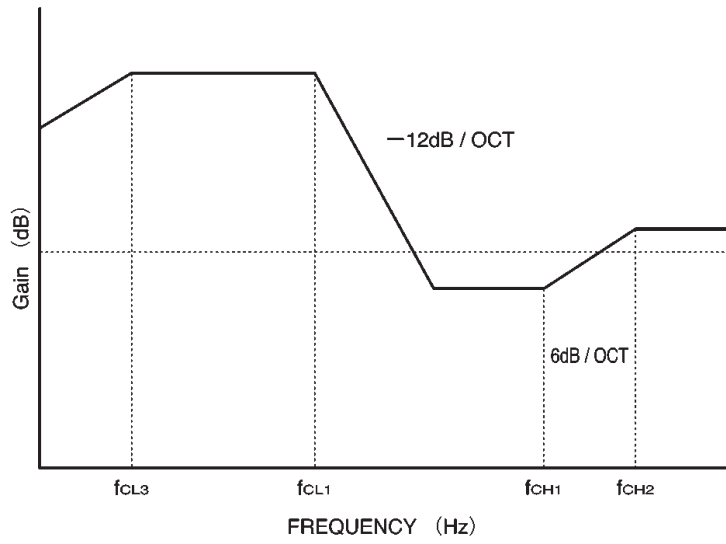

Fig. 7 Total frequency characteristics when BBS is on

4. Bass boost control system

Bass boost control is as follows in Fig. 8.

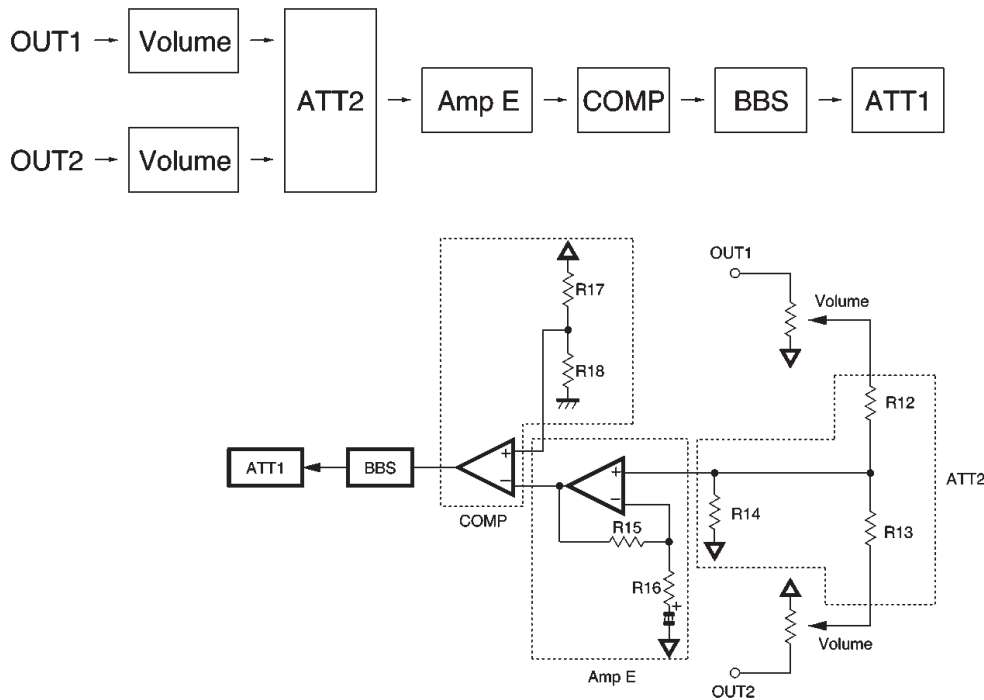

Fig. 8 Bass boost control system

The comparator level and gain of each block are given by the following equations.

Attenuation of ATT2:

$$: G_{ATT2} = 20\log \frac{R_{13}/R_{14}}{R_{12} + R_{13}/R_{14}} \quad (\text{dB})$$

Gain of Amp E:

$$: G_E = 20\log \frac{R_{15} + R_{16}}{R_{16}} \quad (\text{dB})$$

Comparator level of COMP:

$$: V_{COM} = 20\log \left(\frac{V_B}{\sqrt{2}} \cdot \frac{R_{17}}{R_{17} + R_{18}} \right) \quad (\text{dBV})$$

V_B : DC voltage at BIAS OUT pin

If the volume output level at the beginning of control of the low range signal system ATT1 is V_{BBS} (dBV),

$$V_{BBS} + G_{ATT2} + G_E = V_{COM}$$

In this way, bass boost control is carried out based on the volume as shown in Fig. 9.

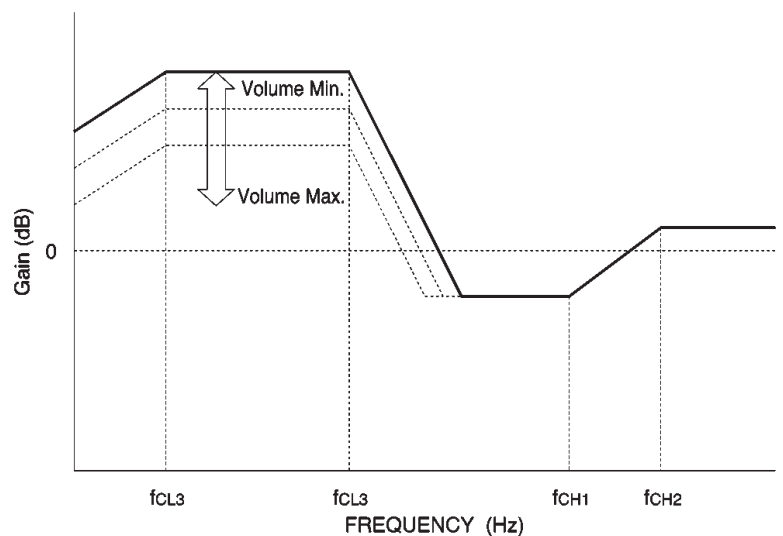
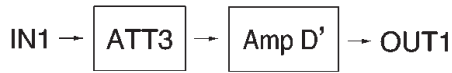

Fig. 9 Characteristics of bass boost control based on the volume

2) BBS off

When BBS is off, the signal system is as shown in Fig. 10 due to the switches in the IC, and signal flow is as follows.



The frequency characteristics of each block are shown in Fig. 11, and the gains are given by the following equations:

$$\text{Attenuation of ATT3: } G_{\text{ATT3}} = 20 \log \frac{R_{20}}{R_{19} + R_{20}} \quad (\text{dB})$$

$$\text{Gain of Amp D': } G_{\text{D}'} = 20 \log \frac{R_{21} + R_{22}}{R_{21}} \quad (\text{dB})$$

As $R_{19} = R_{20}$ and $R_{21} = R_{22}$, the total gain G_{OFF} when BBS is off is

$$G_{\text{OFF}} = G_{\text{ATT3}} + G_{\text{D}'} \\ = 0 \text{ (dB)}$$

and the characteristics are flat as shown in Fig. 12

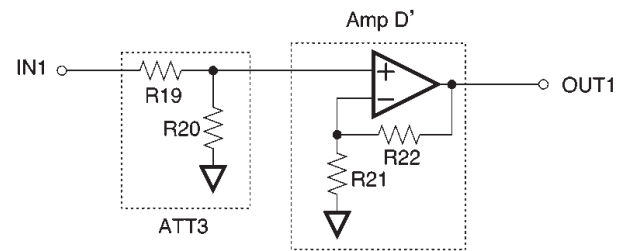

Fig. 10 Signal system when BBS is off

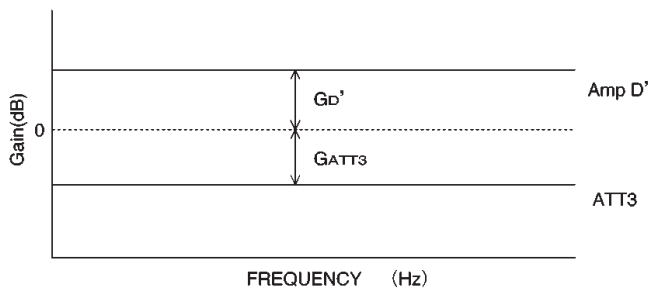

Fig. 11 Frequency characteristics of each block when BBS is off

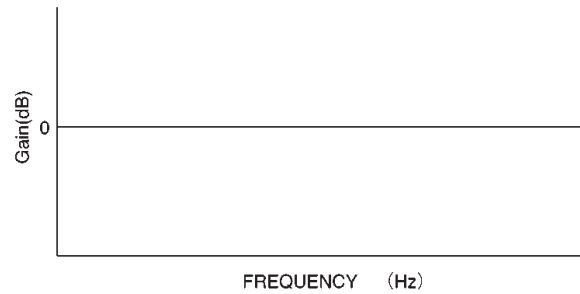

Fig. 12 Total frequency characteristics when BBS is off

●Application examples

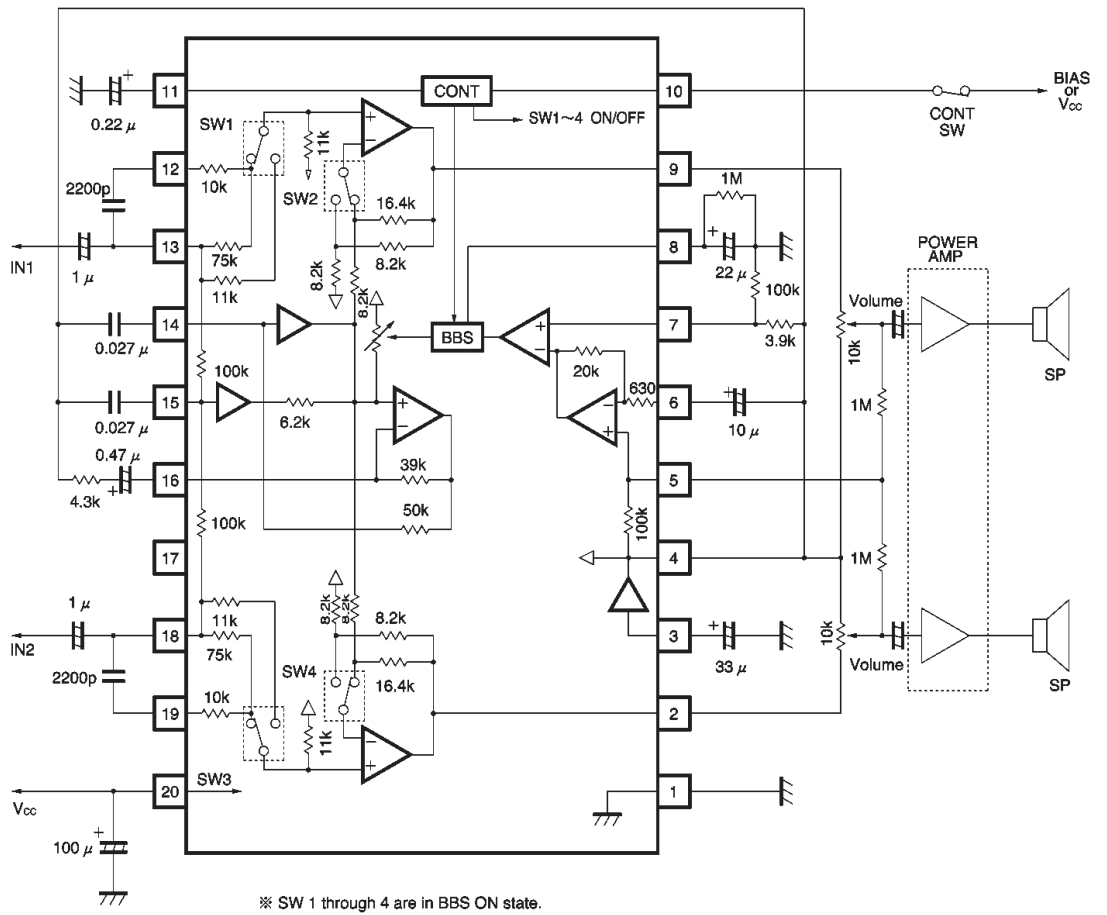

Fig.13

●Electrical characteristic curves

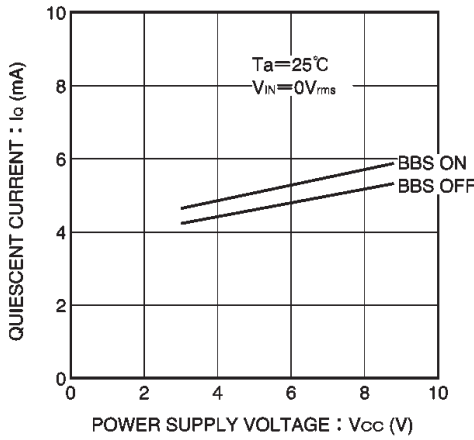

Fig. 15 Quiescent current vs. power supply voltage

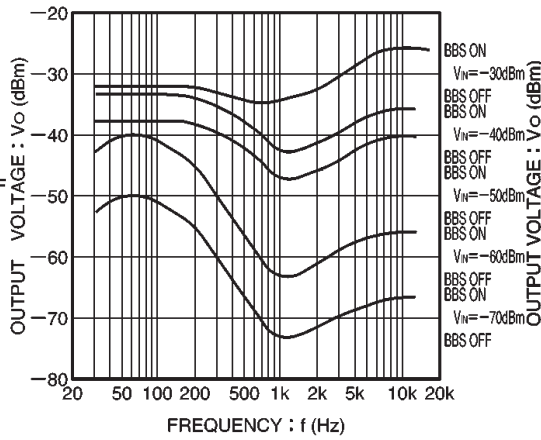

Fig. 16 Output voltage vs. frequency

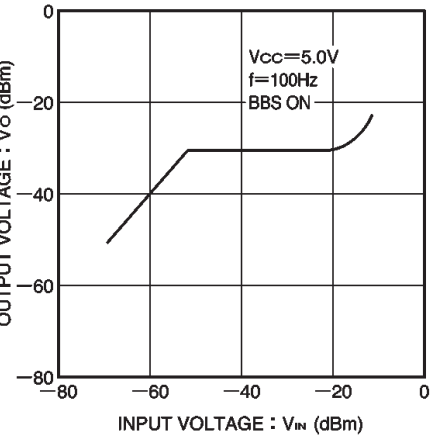

Fig. 17 Output voltage vs. input voltage

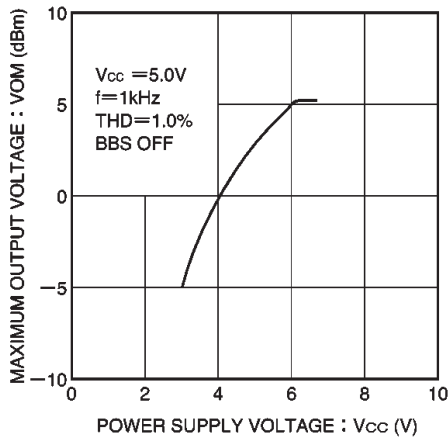

Fig. 18 Maximum output voltage vs. power supply voltage

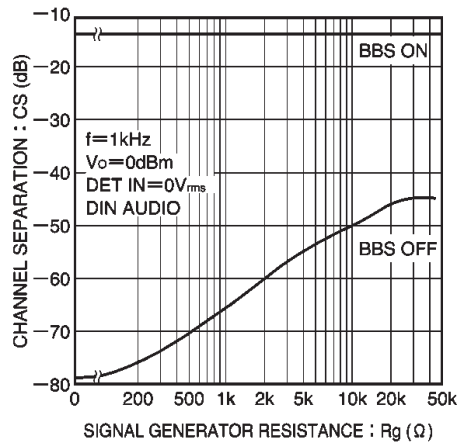

Fig. 19 Channel separation vs. signal generator resistance

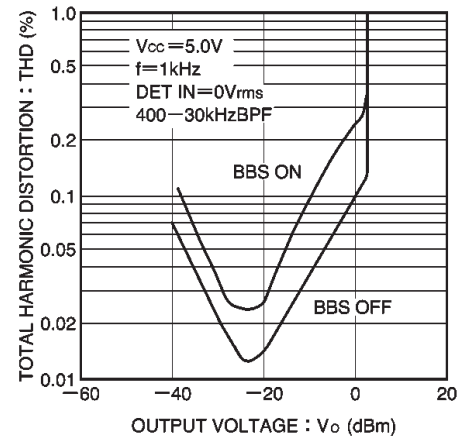

Fig. 20 Total harmonic distortion percentage vs. output voltage

●External dimensions (Units: mm)

