

<b>SANYO</b>	No.4702	<b>LA7156</b>
		<b>Video and Audio Switch for PAL-SECAM 21-Pin Interface</b>

## Overview

The LA7156 is a switching IC for use with the PAL and SECAM 21-pin connector interface. The LA7156 integrates video and audio switches in a single chip, and allows significant block reorganization and integration by providing function switching outputs with current limiters, 75  $\Omega$  video drivers, muting and other functions. The LA7156 provides a diverse set of functions, including support for single-wire serial bus control that allows complex logic to be handled by microprocessor software.

## Functions and Features

- Three audio and three video switching systems
- Audio output and video decoder output muting function
- Video input sync chip clamp
- Two 6 dB video amplifier plus 75  $\Omega$  driver systems
- VPS decoder output
- FSS output with current limiting
- 5 V regulator built-in
- Serial control

## Specifications

### Absolute Maximum Ratings at $T_a = 25^\circ\text{C}$

Parameter	Symbol	Conditions	Ratings	Unit
Maximum supply voltage	$V_{CC \text{ max}}$		15	V
Allowable power dissipation	$P_d \text{ max}$	$T_a \leq 65^\circ\text{C}$	800	mW
Operating temperature	$T_{op}$		-20 to +65	$^\circ\text{C}$
Storage temperature	$T_{stg}$		-55 to +150	$^\circ\text{C}$

### Operating Conditions at $T_a = 25^\circ\text{C}$

Parameter	Symbol	Conditions	Ratings	Unit
Recommended supply voltage	$V_{CC}$		9, 12	V
Operating supply voltage range	$V_{CC \text{ op}}$		8 to 13	V

## Package Dimensions

unit: mm

### 3067-DIP24S

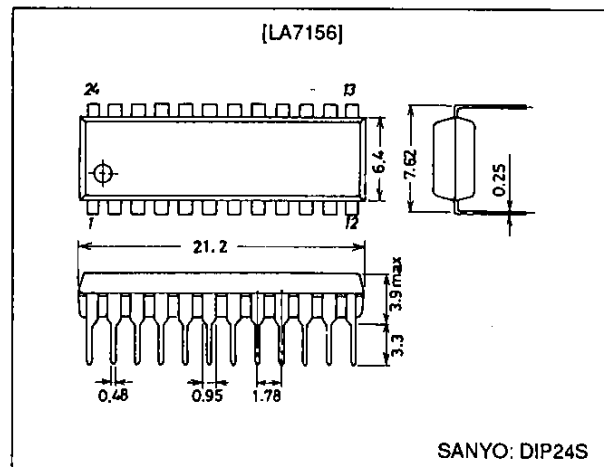

Operating Characteristics at  $T_a = 25^\circ\text{C}$ ,  $V_{CC} = 9\text{ V}$  and  $12\text{ V}$ 

Parameter	Symbol	Conditions	min	typ	max	Unit
Current drain	$I_{CC}$	No input	32	40	48	mA
FSS output high level voltage 1	VHFSS1	$V_{CC} = 9\text{ V}$ , load resistance: $10\text{ k}\Omega$	7.5	8.9	9.0	V
FSS output low level voltage 1	VLFS1	$V_{CC} = 9\text{ V}$ , load resistance: $10\text{ k}\Omega$		0	0.5	V
FSS output high level voltage 2	VHFSS2	$V_{CC} = 12\text{ V}$ , load resistance: $10\text{ k}\Omega$	10.5	11.9	12.0	V
FSS output low level voltage 2	VLFS2	$V_{CC} = 12\text{ V}$ , load resistance: $10\text{ k}\Omega$		0	0.5	V
FSS output cutoff current 1	$I_{CUTOFF1}$	$V_{CC} = 9\text{ V}$ , the outflow current when the FSS output is grounded		9.3	40.0	mA
FSS output cutoff current 2	$I_{CUTOFF2}$	$V_{CC} = 12\text{ V}$ , the outflow current when the FSS output is grounded		9.8	40.0	mA
[Audio Switch Block]						
Total harmonic distortion	THD	$V_{IN} = 1\text{ Vrms}$ , $f = 1\text{ kHz}$ , $R_{OUT} = \infty$		0.02	1	%
Maximum output voltage	$V_O\text{ max}$	The output level when $f = 1\text{ kHz}$ and $\text{THD} = 2\%$	2	3		Vrms
Output noise voltage	$V_{NO}$	$R_g = 600\ \Omega$ , DIN audio filter		-100	-90	dBV
Voltage gain A	$V_{GA}$	The TP6 and TP8 output levels when $V_{IN} = 1\text{ Vrms}$ and $f = 1\text{ kHz}$	1.1	1.8	2.5	dB
Interchannel crosstalk A	CTA	$V_{IN} = 1\text{ Vrms}$ , $f = 1\text{ kHz}$		-90	-70	dB
Muting attenuation A	$V_{muteA}$	$V_{IN} = 1\text{ Vrms}$ , $f = 1\text{ kHz}$		-90	-70	dB
Output offset voltage	$V_{of}$	The offset voltage when the switch has changed state		0	20	mV
Input impedance A	$Z_{IN A}$		40	50	60	$\text{k}\Omega$
[Video Switch Block]						
Voltage gain V	$V_{GV}$	The TP2 and TP5 output levels when $V_{IN} = 1\text{ Vp-p}$ and $f = 4.43\text{ MHz}$	-1	0	+1	dB
Frequency characteristics	$V_f$	$V_{IN} = 1\text{ Vp-p}$ , $f = 100\text{ k7 MHz}$	-1.5	-0.5	+0.5	dB
Second harmonic	H2	$V_{IN} = 1\text{ Vp-p}$ , $f = 4.43\text{ MHz}$		-45	-40	dB
Third harmonic	H3	$V_{IN} = 1\text{ Vp-p}$ , $f = 4.43\text{ MHz}$		-50	-45	dB
Interchannel crosstalk V	CTV	$V_{IN} = 1\text{ Vp-p}$ , $f = 4.43\text{ MHz}$		-50	-40	dB
Muting attenuation V	$V_{muteV}$	$V_{IN} = 1\text{ Vp-p}$ , $f = 4.43\text{ MHz}$		-50	-40	dB
Output voltage	$V_{OUT}$	The TP5 DC voltage with no input		0.7	1.0	V
[Control Block]						
Serial control input high level	$V_{sh}$		4		5	V
Serial control input middle level	$V_{sm}$		2		3	V
Serial control input low level	$V_{sl}$		0		1	V
Pin 2 input high level	V2H		4		$V_{CC}$	V
Pin 2 input low level	V2L	*1	0		2	V
Pin 20 input high level	V20H		4		$V_{CC}$	V
Pin 20 input middle level	V20M	*2	2		3	V
Pin 20 input low level	V20L		0		1	V
Pin 7 output high level	V7H	The TP9 DC voltage when SW3 is in the A position	4.5	5.0	5.5	V
Pin 7 output low level	V7L	The TP9 DC voltage when SW3 is in the B position	0		1	V

Note: In the operating characteristics listed above, characteristics items that do not differ between  $V_{CC} = 9\text{ V}$  and  $12\text{ V}$  are listed as the same item.

1. Forced to low when pin 2 is open.
2. Forced to the middle level when pin 20 is open.

**Timing Characteristics**

Parameter	Symbol	Conditions	min	typ	max	Unit
Minimum input pulse width	$t_w$		2			$\mu s$
Rise time	$t_r$				20	$\mu s$
Fall time	$t_f$				20	$\mu s$

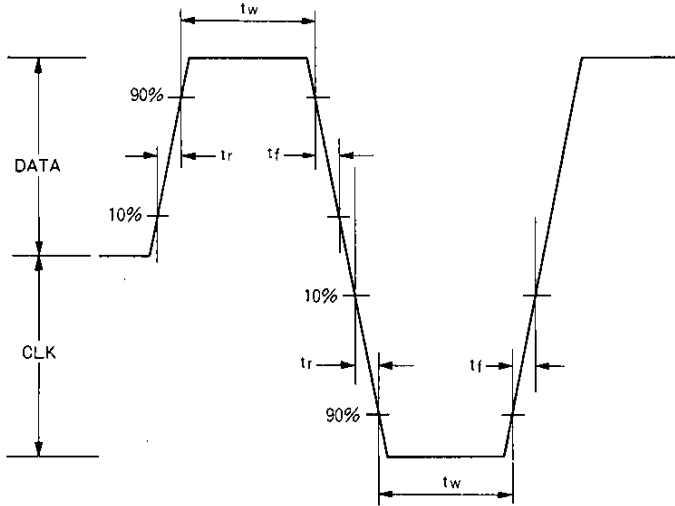

**Serial Control Input Specifications**

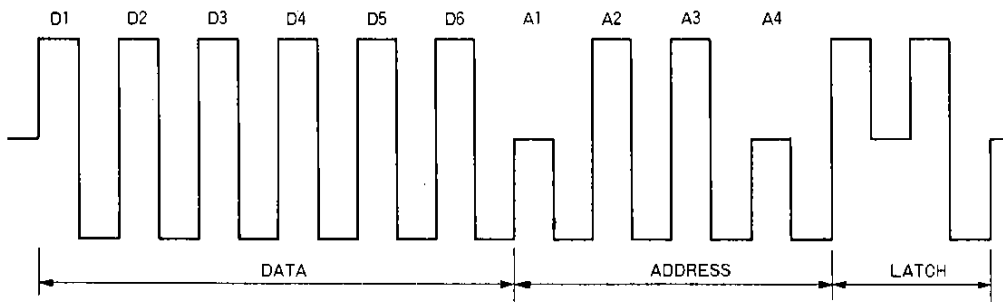

**LA7156 Command Address**

Address	A1	A2	A3	A4
State	L	H	H	L

## LA7156

### Switch Logic Values Table

The LA7156 provides the following switching control with control of pin 20.

#### 1. Normal mode (when pin 20 is high)

In this mode, the LA7156 functions, including switching, FSS output and muting, can be controlled from the six bits of serial data transferred from the microprocessor. However, note that the video and audio system switch operate at the same time in this mode.

DATA1		Switch state	Note	DATA4	Switch state	Note
H		A.SW1-A, V.SW1-A	1, 2	H	A.SW3-A, V.SW3-A, pin 7 high	1, 2
L		A.SW1-B, V.SW1-B	1, 2	L	A.SW3-B, V.SW3-B, pin 7 low	1, 2
DATA2	DATA3	Switch state	Note	DATA5	FSS output state	Note
H	L	A.SW2-A, V.SW2-A	1, 2	H	Output high	
L	L	A.SW2-B, V.SW2-B	1, 2	L	Output low	
—	H	A.SW2-C, V.SW2-C	1, 2	DATA6	Muted state	Note
				H	Muted	
				L	Mute released	

Note: 1. All the audio switch and the video SW3 outputs are forcibly muted when DATA6 is high or in muting mode.  
2. A.SW indicates the audio system switches and V.SW indicates the video system switches.

#### 2. Preset mode (when pin 20 is middle or low)

This mode uses the LA7156 internally set up logic and the six bits of data are allocated to the VCR operating states to allow the switch states to be changed.

#### Serial Data

DATA No.	Item	H	L
D1	Power on/off	On	Off
D2	VCR/TV	VCR	TV
D3	Pay CH/Normal CH	Pay	Normal
D4	EXT/Tuner	EXT	Tuner
D5	PB/EE	PB	EE
D6	Mute on/off	On	Off

#### External Input Data

Pin No.	Item	H	L
P2	Decoder in	Scramble	Normal

### Truth Table

Pin 20: Open or Middle

D1	D2	D3	D4	D5	P2	A.V.SW1	A.V.SW2	A.V.SW3	FSS out	Pin 7 out
L	—	—	—	—	H	A	C	A	L	H
L	—	—	—	—	L	A	C	A	L	H
H	L	—	L	L	H	A	A	A	L	H
H	L	—	L	L	L	A	C	A	L	H
H	H	—	L	L	H	A	A	A	H	H
H	H	—	L	L	L	A	C	A	H	H
H	L	—	H	L	H	A	B	A	L	H
H	L	—	H	L	L	A	B	A	L	H
H	H	—	H	L	H	A	B	A	H	H
H	H	—	H	L	L	A	B	A	H	H
H	—	—	—	H	H	A	*	A	H	H
H	—	—	—	H	L	A	*	A	H	H

Note: The previous state is retained even if another switch is changed.

LA7156

Pin 20: Low

D1	D2	D3	D4	D5	P2	A.V.SW1	A.V.SW2	A.V.SW3	FSS out	Pin 7 out
L	—	—	—	—	H	B	A	B	H	L
L	—	—	—	—	L	B	A	B	L	L
H	L	L	L	L	H	B	C	B	H	L
H	L	L	L	L	L	A	C	B	L	L
H	H	L	L	L	H	A	C	A	H	H
H	H	L	L	L	L	A	C	A	H	H
H	L	H	L	L	H	A	A	A	L	H
H	L	H	L	L	L	A	C	A	L	H
H	H	H	L	L	H	A	A	A	H	H
H	H	H	L	L	L	A	C	A	H	H
H	L	—	H	L	H	A	A	B	H	L
H	L	—	H	L	L	A	B	B	L	L
H	H	—	H	L	H	A	A	B	H	L
H	H	—	H	L	L	A	B	B	H	L
H	—	—	—	H	H	A	*	*	H	*
H	—	—	—	H	L	A	*	*	H	*

Note: The previous state is retained even if another switch is changed.

Block Diagram and Recommended Circuit Diagram

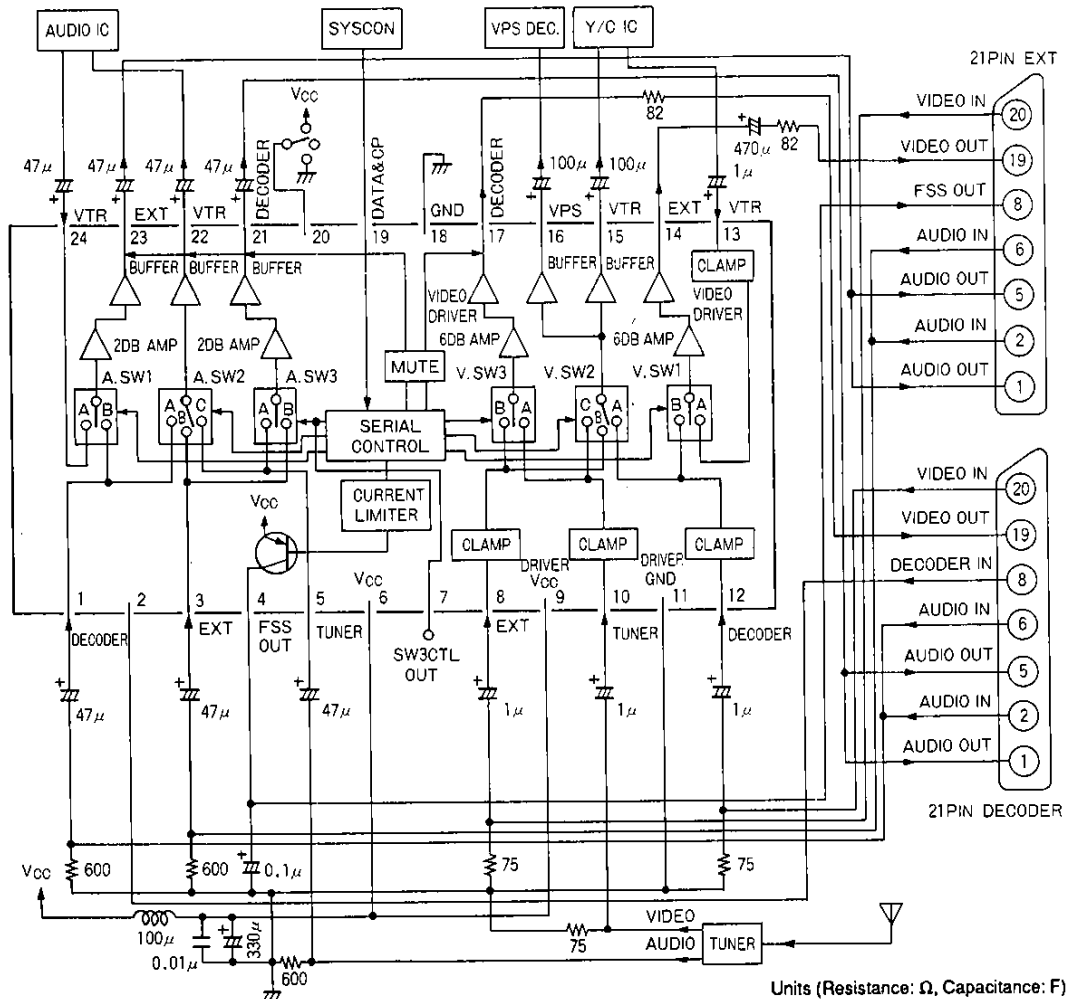

# LA7156

## Test Circuit

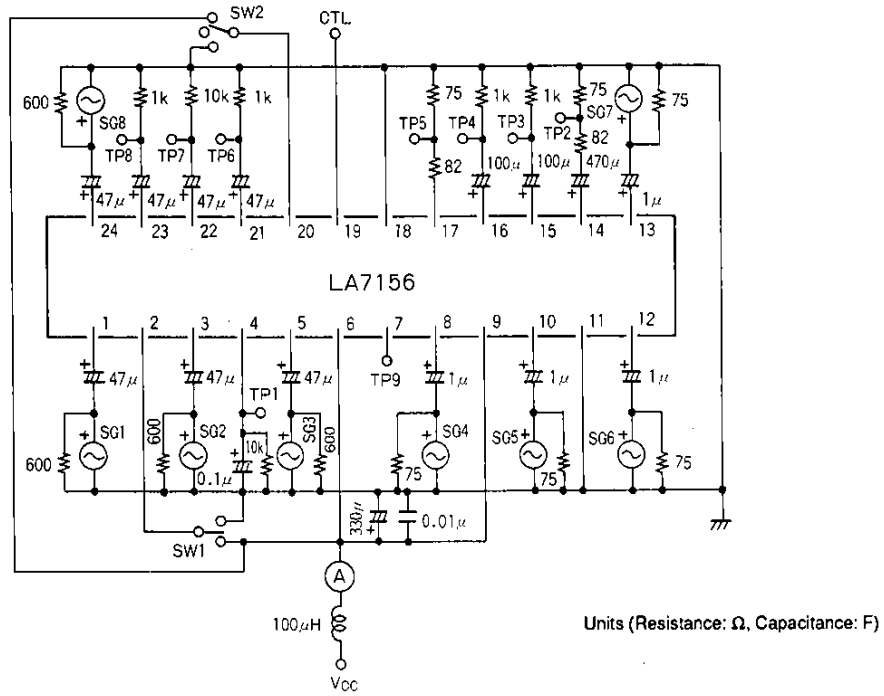

## Input and Output Pin Circuit Diagrams

Unit (Resistance: Ω, Current source: A)

Pin No.	Symbol	I/O circuit	DC voltage	Note
1 3 5 24	$A_{IN1}$ $A_{IN2}$ $A_{IN3}$ $A_{IN4}$		$\frac{1}{2} V_{CC} + 0.7 V$	
2	DEC IN			
4	FSS OUT		$V_{CC} - 0.2 V$	
6	$V_{CC}$			

Continued on next page.

LA7156

Continued from preceding page.

Unit (Resistance:  $\Omega$ , Current source: A)

Pin No.	Symbol	I/O circuit	DC voltage	Note
7	SW3 CTL OUT		H: 5.0 V L: 0 V	
8 10 12 13	$V_{IN1}$ $V_{IN2}$ $V_{IN3}$ $V_{IN4}$		2.5 V	
9	DRIVER $V_{CC}$			
11	DRIVER GND			
14	$V_{OUT1}$		1.6 V	External connection
17	$V_{OUT2}$			
15	$V_{OUT3}$		1.6 V	Signal processing IC connection
16	$V_{OUT4}$		1.6 V	Signal processing IC connection
18	GND			

LA7156

Continued from preceding page.

Unit (Resistance:  $\Omega$ , Current source: A)

Pin No.	Symbol	I/O circuit	DC voltage	Note
19	D/C IN		2.5 V	
20	MODE CTL IN		2.5 V	
21	A <sub>OUT1</sub>		1/2 V <sub>CC</sub>	External connection
23	A <sub>OUT2</sub>			
22	A <sub>OUT3</sub>		1/2 V <sub>CC</sub>	Signal processing IC connection

■ No products described or contained herein are intended for use in surgical implants, life-support systems, aerospace equipment, nuclear power control systems, vehicles, disaster/crime-prevention equipment and the like, the failure of which may directly or indirectly cause injury, death or property loss.

■ Anyone purchasing any products described or contained herein for an above-mentioned use shall:

- ① Accept full responsibility and indemnify and defend SANYO ELECTRIC CO., LTD., its affiliates, subsidiaries and distributors and all their officers and employees, jointly and severally, against any and all claims and litigation and all damages, cost and expenses associated with such use;
- ② Not impose any responsibility for any fault or negligence which may be cited in any such claim or litigation on SANYO ELECTRIC CO., LTD., its affiliates, subsidiaries and distributors or any of their officers and employees jointly or severally.

■ Information (including circuit diagrams and circuit parameters) herein is for example only; it is not guaranteed for volume production. SANYO believes information herein is accurate and reliable, but no guarantees are made or implied regarding its use or any infringements of intellectual property rights or other rights of third parties.

This catalog provides information as of **December, 1996**. Specifications and information herein are subject to change without notice.