	No. 5109	LA7416,7416M
	<b>Playback Amplifier and Record Amplifier for VHS VCRs</b>	

## Overview

The LA7416 and LA7416M are playback and record amplifier ICs for four-head VHS VCRs. When used in conjunction with the video signal processing ICs of the LA7420/30 series, it is possible to eliminate the need to adjust the Y/C record current.

## Functions

- 4-channel playback amplifier.
- 2-channel recording amplifier (AGC built-in).
- REC/PB mode switching head switch circuit.
- Envelope wave detection (for auto-tracking).
- Envelope comparator.

## Features

- The record amplifier provides stable record characteristics in constant current drive mode, which is able to withstand load fluctuations. In addition, the built-in AGC eliminates the need to adjust the record current.
- Designed to share printed circuit boards with the LA7411/7411M (for 2-head systems).

## Specifications

### Maximum Ratings at Ta = 25 °C

Parameter	Symbol	Conditions	Ratings	Unit
Maximum supply voltage	V <sub>CCmax</sub>		7.0	V
Allowable power dissipation	Pd max	Ta ≤ 65 °C	650	mW
			*500	mW
Operating temperature	T <sub>opr</sub>		-10 to +65	°C
Storage temperature	T <sub>stg</sub>		-40 to +150	°C

\*: LA7416M Pd max value which represents the value when mounted on the board.

## Package Dimensions

unit : mm

### 3196-DIP30SD

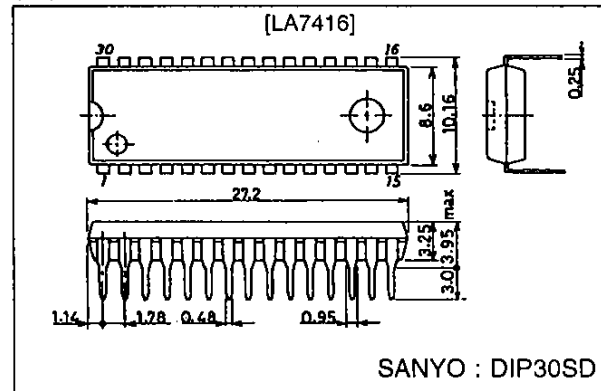

### 3073A-MFP30SD

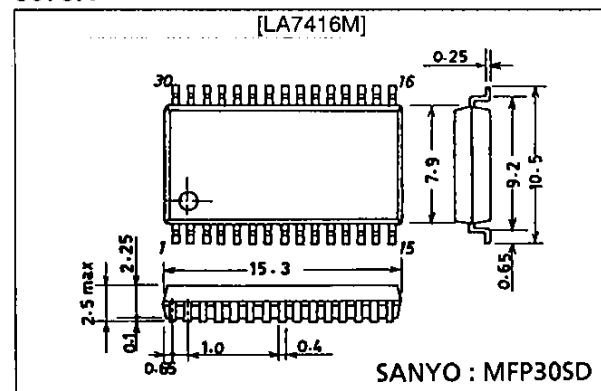

# LA7416,7416M

## Operating Conditions at Ta = 25 °C

Parameter	Symbol	Conditions	Ratings	Unit
Supply voltage	V <sub>CC</sub>		5.0	V
Operating voltage range	V <sub>CCOP</sub>		4.8 to 5.5	V

## Electrical Characteristics at Ta = 25 °C

Parameter	Symbol	Input	Output	Conditions	T2	T4	T5	min	typ	max	Unit																
[PB Mode]				T15: 5.0 V T13: Open T7: Open	TRCK	HA	SW30 MUTE																				
Current consumption	I <sub>CCP</sub>			Pin 15 input current	Open	0	0	26	30	34	mA																
Voltage gain	SP L	CH1	G <sub>VP1</sub>	T20A	T10A	V <sub>I</sub> = 38 mVp-p f = 1 MHz						Open	0	0	54.0	57.0	60.0	dB									
	SP H	CH2	G <sub>VP2</sub>	T23A	T10A							Open	0	2.5	54.0	57.0	60.0	dB									
	EP L	CH3	G <sub>VP3</sub>	T27A	T10A							Open	5.0	0	56.0	59.0	62.0	dB									
	EP H	CH4	G <sub>VP4</sub>	T30A	T10A							Open	5.0	2.5	56.0	59.0	62.0	dB									
Voltage gain difference 1	ΔG <sub>VP1</sub>			G <sub>VP1</sub> — G <sub>VP2</sub>				-1	0	+1	dB																
Voltage gain difference 2	ΔG <sub>VP2</sub>			G <sub>VP3</sub> — G <sub>VP4</sub>				-1	0	+1	dB																
Intermode gain difference	ΔG <sub>VP EP-SP</sub>			G <sub>VP3</sub> — G <sub>VP1</sub>				1.0	2.0	3.0	dB																
Equivalent input noise voltage	CH1	V <sub>NIN1</sub>	T20A	T10A	After 1.1 MHz LPF $\frac{V_{OUT}}{G_{VP1,2,3,4}}$	Open	0	0				1.1	1.5	μVrms													
	CH2	V <sub>NIN2</sub>	T23A	T10A								Open	0	2.5	1.1	1.5	μVrms										
	CH3	V <sub>NIN3</sub>	T27A	T10A								Open	5.0	0	1.1	1.5	μVrms										
	CH4	V <sub>NIN4</sub>	T30A	T10A								Open	5.0	2.5	1.1	1.5	μVrms										
Frequency characteristics	CH1	ΔV <sub>fp1</sub>	T20A	T10A	V <sub>I</sub> = 38 mVp-p f = 7 MHz $\frac{V_{OUT}}{G_{VP1,2,3,4}}$ output ratio	Open	0	0	-2.5	+1																	
	CH2	ΔV <sub>fp2</sub>	T23A	T10A															Open	0	2.5	-2.5	+1				
	CH3	ΔV <sub>fp3</sub>	T27A	T10A															Open	5.0	0	-2.5	+1				
	CH4	ΔV <sub>fp4</sub>	T30A	T10A															Open	5.0	2.5	-2.5	+1				
Secondary harmonic distortion	CH1	V <sub>HDP1</sub>	T20A	T10A	V <sub>I</sub> = 38 mVp-p f = 4 MHz 8 M component 4 M component output ratio	Open	0	0																			
	CH2	V <sub>HDP2</sub>	T23A	T10A															Open	0	2.5	-40	-35	dB			
	CH3	V <sub>HDP3</sub>	T27A	T10A															Open	5.0	0	-40	-35	dB			
	CH4	V <sub>HDP4</sub>	T30A	T10A															Open	5.0	2.5	-40	-35	dB			
Maximum output level	CH1	V <sub>OMP1</sub>	T20A	T10A	f = 1 MHz Output level when tertiary distortion of the output is -30 dB	Open	0	0	1.0	1.2																	
	CH2	V <sub>OMP2</sub>	T23A	T10A															Open	0	2.5	1.0	1.2	Vp-p			
	CH3	V <sub>OMP3</sub>	T27A	T10A															Open	5.0	0	1.0	1.2	Vp-p			
	CH4	V <sub>OMP4</sub>	T30A	T10A															Open	5.0	2.5	1.0	1.2	Vp-p			
Cross-talk SP (Note 1)	CH1	V <sub>CR1</sub>	T23A	T10A	V <sub>I</sub> = 38 mVp-p f = 4 MHz $\frac{V_{OUT}}{G_{VP1,2}}$	Open	0	0																			
			T27A	T10A															Open	0	0	-40	-35	dB			
			T30A	T10A															Open	0	0	-40	-35	dB			
	CH2	V <sub>CR2</sub>	T20A	T10A															Open	0	2.5	-40	-35	dB			
			T27A	T10A															Open	0	2.5	-40	-35	dB			
			T30A	T10A															Open	0	2.5	-40	-35	dB			
Cross-talk EP (Note 1)	CH3	V <sub>CR3</sub>	T20A	T10A	V <sub>I</sub> = 38 mVp-p f = 4 MHz $\frac{V_{OUT}}{G_{VP3,4}}$	Open	5.0	0																			
			T23A	T10A															Open	5.0	0	-40	-35	dB			
			T30A	T10A															Open	5.0	0	-40	-35	dB			
	CH4	V <sub>CR4</sub>	T20A	T10A															Open	5.0	2.5	-40	-35	dB			
			T23A	T10A															Open	5.0	2.5	-40	-35	dB			
			T27A	T10A															Open	5.0	2.5	-40	-35	dB			

Continued on next page.

# LA7416,7416M

Continued from preceding page.

Parameter	Symbol	Input	Output	Conditions	T2	T4	T5	min	typ	max	Unit
Output DC offset	$\Delta V_{ODC1}$		T10A	CH1—CH2	Open		0	-100	0	+100	mV
					Open	0	2.5	-100	0	+100	mV
	$\Delta V_{ODC2}$		T10A	CH3—CH4	Open		0	-100	0	+100	mV
					Open	5.0	2.5	-100	0	+100	mV
	$\Delta V_{ODC3}$		T10A	CH1—CH3	Open			-100	0	+100	mV
					Open	5.0	0	-100	0	+100	mV
	$\Delta V_{ODC4}$		T10A	CH2—CH4	Open			-100	0	+100	mV
					Open	5.0	2.5	-100	0	+100	mV
	$\Delta V_{ODC5}$		T10A	CH1—CH4	Open		0	-100	0	+100	mV
					Open	5.0	2.5	-100	0	+100	mV
	$\Delta V_{ODC6}$		T10A	CH2—CH3	Open		0	-100	0	+100	mV
					Open	5.0	0	-100	0	+100	mV
Envelope wave detection output pin voltage	$V_{ENV}$		T8	T8 DC voltage with no input	Open	0	0	0	0.8	1.5	V
Envelope wave detection voltage SP1	$V_{ENVSP1}$	T20A	T8	f = 4 MHz, T10A: Adjusted to 175 mVp-p	Open	0	0	2.1	2.6	3.1	V
Envelope wave detection voltage SP2	$V_{ENVSP2}$	T20A	T8	f = 4 MHz, T10A: Adjusted to 450 mVp-p	Open	0	0	4.5	4.8	5.0	V
Envelope wave detection voltage EP1	$V_{ENVEP1}$	T27A	T8	f = 4 MHz, T10A: Adjusted to 125 mVp-p	Open	5.0	0	2.0	2.5	3.0	V
Envelope wave detection voltage EP2	$V_{ENVEP2}$	T27A	T8	f = 4 MHz, T10A: Adjusted to 350 mVp-p	Open	5.0	0	4.5	4.8	5.0	V
Comparator output voltage 1	$V_{COMP1}$	T20A	T3	f = 4 MHz, $V_I = 38$ mVp-p T3 DC voltage	5.0	0	0		0.4	0.7	V
Comparator output voltage 2	$V_{COMP2}$	T27A	T3	f = 4 MHz, $V_I = 38$ mVp-p T3 DC voltage	5.0	5.0	0	4.5	4.8		V
ON resistance of SW-Tr which is turned ON in PB mode	$R_{PON17}$		P-17	DC difference measured for 1 mA, 2 mA current inflow					4.0	6.0	$\Omega$
	$R_{PON18}$		P-18						4.0	6.0	$\Omega$
ON resistance of SW-Tr which is turned ON in PB mode	$R_{PON21}$		P-21	DC difference measured for 1 mA, 2 mA current inflow	Open	5.0			4.0	6.0	$\Omega$
	$R_{PON24}$		P-24		Open	5.0			4.0	6.0	$\Omega$
	$R_{PON26}$		P-26		Open	0			4.0	6.0	$\Omega$
	$R_{PON29}$		P-29		Open	0			4.0	6.0	$\Omega$
Trick 1 threshold level	TR1-1		T2	Normal → Trick 1	*			3.2		5.0	V
	TR1-2		T2	Trick 1 → Normal	*			1.2		2.8	V
Trick 2 threshold level	TR2-1		T2	Normal → Trick 2	*			0.0		0.8	V
	TR2-2		T2	Trick 2 → Normal	*			1.2		2.8	V
HAPB threshold level	HAP-1		T4	SP → EP		*		1.8		5.0	V
	HAP-2		T4	EP → SP		*		0.0		1.4	V
SW30 threshold level	SW30-1		T5	Lch → Hch			*	1.2		5.0	V
	SW30-2		T5	Hch → Lch			*	0.0		0.8	V

Note 1: Status where input stage L (8.2  $\mu$ H) is shorted

Note: Because the T4 (HA) control switching timing is synchronized with T6 (H-Sync), a trigger pulse (0 V to 5 V to 0 V) must be input to T6 before measuring each parameter for the LA7416/M.

\*\*\*\* represents output pins.

## LA7416,7416M

### Electrical Characteristics at Ta = 25 °C

Parameter	Symbol	Input	Output	Conditions	T13	T4	T5	min	typ	max	Unit
[REC Mode]				T15: 5.0 V T2: Open T6: 5.0 V T7: 5.0 V	REC Adj2	HA	SW30 MUTE				
Current consumption	I <sub>CCP</sub>			Pin 15 current input	Open	0	0	50	55	60	mA
REC AGC Amp output level	V <sub>RSP</sub>	T11A	T21A	f = 4 MHz	Open	0	0	147	156	165	mVp-p
	V <sub>REP</sub>	T11A	T26A	V <sub>I</sub> = 200 mVp-p	Open	5.0	0	116	123	130	mVp-p
Intermode gain difference	ΔG <sub>VR</sub>			V <sub>RSP</sub> /V <sub>REP</sub>				1.30	2.05	2.80	dB
REC AGC Amp control characteristics 1	ΔV <sub>AGC1-SP</sub>	T11A	T21A	f = 4 MHz, V <sub>I</sub> = 400 mVp-p	Open	0	0		0.5	1.0	dB
	ΔV <sub>AGC1-EP</sub>	T11A	T26A	Output level/ V <sub>RSP, EP</sub> ratio	Open	5.0	0		0.5	1.0	dB
REC AGC Amp control characteristics 2	ΔV <sub>AGC2-SP</sub>	T11A	T21A	f = 4 MHz, V <sub>I</sub> = 100 mVp-p	Open	0	0	-1.0	-0.5		dB
	ΔV <sub>AGC2-EP</sub>	T11A	T26A	Output level/ V <sub>RSP, EP</sub> ratio	Open	5.0	0	-1.0	-0.5		dB
REC AGC Amp frequency characteristics (Note 2)	ΔV <sub>FRS</sub>	T11A	T21A	f = 1 M, 7 MHz, V <sub>I</sub> = 200 mVp-p	Open	0	0	-4.0	-3.0	-2.0	dB
	ΔV <sub>FRE</sub>	T11A	T26A	7 MHz/1 MHz, output ratio	Open	5.0	0	-4.0	-3.0	-2.0	dB
REC AGC Amp secondary harmonic level	ΔV <sub>HDRS</sub>	T11A	T21A	f = 4 MHz, V <sub>I</sub> = 200 mVp-p	Open	0	0		-45	-40	dB
	ΔV <sub>HDRE</sub>	T11A	T26A	8 M component 4 M component output ratio	Open	5.0	0		-45	-40	dB
REC AGC Amp maximum output level (Note 3)	ΔV <sub>OMRS</sub>	T11A	T21A	f = 4 MHz, Output level when secondary distortion of the output is -30 dB	Adj.	0	0	20	22		mAp-p
	ΔV <sub>OMRE</sub>	T11A	T26A		Adj.	5.0	0	20	22		mAp-p
REC AGC Amp mute attenuation	ΔV <sub>MRS</sub>	T11A	T21A	f = 4 MHz, V <sub>I</sub> = 200 mVp-p	Open	0	5.0		-45	-40	dB
	ΔV <sub>MRE</sub>	T11A	T26A	Output level/ V <sub>RSP, EP</sub> output ratio	Open	5.0	5.0		-45	-40	dB
REC AGC Amp mixed modulation relative level	ΔV <sub>CYS</sub>	T10A	T21A	T10A: f = 629 kHz, V <sub>I</sub> = 360 mVp-p	Open	0	0		-45	-40	dB
	ΔV <sub>CYE</sub>	T11A	T26A	T11A: f = 4 MHz, V <sub>I</sub> = 200 mVp-p (4 M±629 k)/4 M output ratio	Open	5.0	0		-45	-40	dB
ON resistance of SW-Tr which switches between modes in REC mode	R <sub>RON17</sub>		P-17	DC difference measured for 1 mA, 2 mA current inflow	Open	5.0			4.0	6.0	Ω
	R <sub>RON18</sub>		P-18		Open	0			4.0	6.0	Ω
	R <sub>RON21</sub>		P-21		Open	5.0			4.0	6.0	Ω
	R <sub>RON24</sub>		P-24		Open	5.0			4.0	6.0	Ω
	R <sub>RON26</sub>		P-26		Open	0			4.0	6.0	Ω
R <sub>RON29</sub>		P-29	Open	0			4.0	6.0	Ω		
HA REC threshold level	HAR-1		T4	SP → EP		*		1.8		5.0	V
	HAR-2		T4	EP → SP		*		0.0		1.4	V
REC MUTE threshold level	MUTE-1		T5	MUTE OFF → ON			*	3.4		5.0	V
	MUTE-2		T5	MUTE ON → OFF			*	0.0		3.0	V
REC/PB threshold level	SW REC/PB			T7: Control voltage				2.2		5.0	V

Note 2: Apply approximately 1.8 V DC to the AGC wave detection filter pin (pin 12) and fix the amplifier gain for measurement.

Note 3: Apply DC voltage to T13 (REC CUR. ADJ2) and adjust the output level.

Note: Use a resistor with a tolerance of ± 1.0% between pins 14 and 15.

“\*” represents output pins.

Test Circuit Diagram

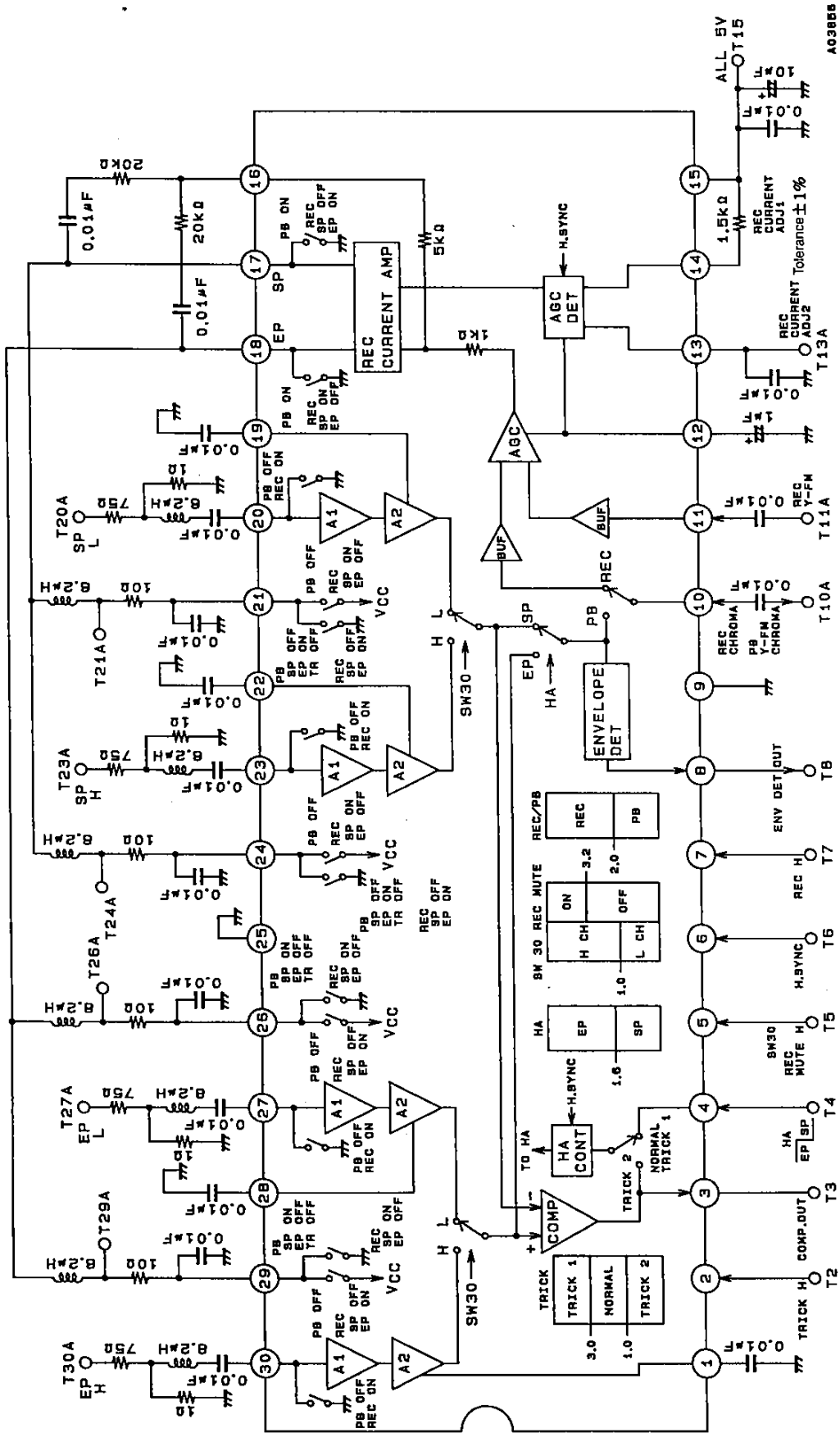

AO3856



- No products described or contained herein are intended for use in surgical implants, life-support systems, aerospace equipment, nuclear power control systems, vehicles, disaster/crime-prevention equipment and the like, the failure of which may directly or indirectly cause injury, death or property loss.
- Anyone purchasing any products described or contained herein for an above-mentioned use shall:
  - ① Accept full responsibility and indemnify and defend SANYO ELECTRIC CO., LTD., its affiliates, subsidiaries and distributors and all their officers and employees, jointly and severally, against any and all claims and litigation and all damages, cost and expenses associated with such use:
  - ② Not impose any responsibility for any fault or negligence which may be cited in any such claim or litigation on SANYO ELECTRIC CO., LTD., its affiliates, subsidiaries and distributors or any of their officers and employees jointly or severally.
- Information (including circuit diagrams and circuit parameters) herein is for example only; it is not guaranteed for volume production. SANYO believes information herein is accurate and reliable, but no guarantees are made or implied regarding its use or any infringements of intellectual property rights or other rights of third parties.

This catalog provides information as of June, 1995. Specifications and information herein are subject to change without notice.