

TOSHIBA CCD LINEAR IMAGE SENSOR CCD (Charge Coupled Device)

TCD2700C

The TCD2700C is a high sensitive and low dark current 7500 elements x 3 line CCD color image sensor. The sensor is designed for color scanner. The device contains a row of 7500 elements x 3 line photodiodes which provide a 24 lines/mm across a A3 size paper. The device is operated by 5V pulse, and 12V power supply.

FEATURES

- Number of Image Sensing Elements : 7500 elements x 3 line
- Image Sensing Element Size : 8 μm by 8 μm on 8 μm centers
- Photo Sensing Region : High sensitive pn photodiode
- Clock : 2 phase (5V)
- Distance Between Photodiode Array : 64 μm (8 Lines)
- Internal Circuit : Sample and Hold circuit, Clamp circuit
- Package : 24 pin DIP
- Color Filter : Red, Green, Blue

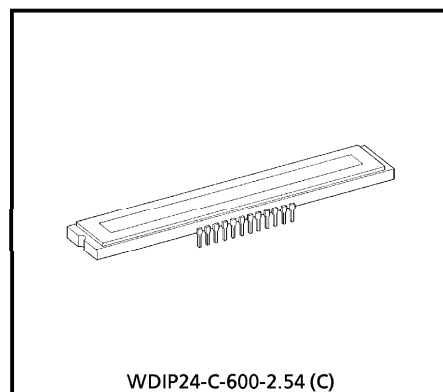

Weight : 17.1 g (Typ.)

MAXIMUM RATINGS (Note 1)

CHARACTERISTIC	SYMBOL	RATING	UNIT
Clock Pulse Voltage	V_{ϕ}	-0.3~8	V
Shift Pulse Voltage	V_{SH}		
Reset Pulse Voltage	V_{RS}		
Clamp Pulse Voltage	V_{CP}		
Sample and Hold Pulse Voltage	V_{SP}		
Power Supply Voltage	V_{OD}	-0.3~15	V
Operating Temperature	T_{opr}	0~60	°C
Storage Temperature	T_{stg}	-25~85	°C

(Note 1) : All voltage are with respect to SS terminals (Ground).

PIN CONNECTIONS

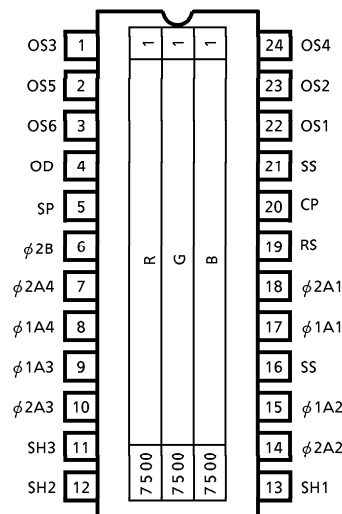

(TOP VIEW)

980910EBA2

● TOSHIBA is continually working to improve the quality and the reliability of its products. Nevertheless, semiconductor devices in general can malfunction or fail due to their inherent electrical sensitivity and vulnerability to physical stress. It is the responsibility of the buyer, when utilizing TOSHIBA products, to observe standards of safety, and to avoid situations in which a malfunction or failure of a TOSHIBA product could cause loss of human life, bodily injury or damage to property. In developing your designs, please ensure that TOSHIBA products are used within specified operating ranges as set forth in the most recent products specifications. Also, please keep in mind the precautions and conditions set forth in the TOSHIBA Semiconductor Reliability Handbook.

● The products described in this document are subject to the foreign exchange and foreign trade laws.

● The information contained herein is presented only as a guide for the applications of our products. No responsibility is assumed by TOSHIBA CORPORATION for any infringements of intellectual property or other rights of the third parties which may result from its use. No license is granted by implication or otherwise under any intellectual property or other rights of TOSHIBA CORPORATION or others.

● The information contained herein is subject to change without notice.

CIRCUIT DIAGRAM

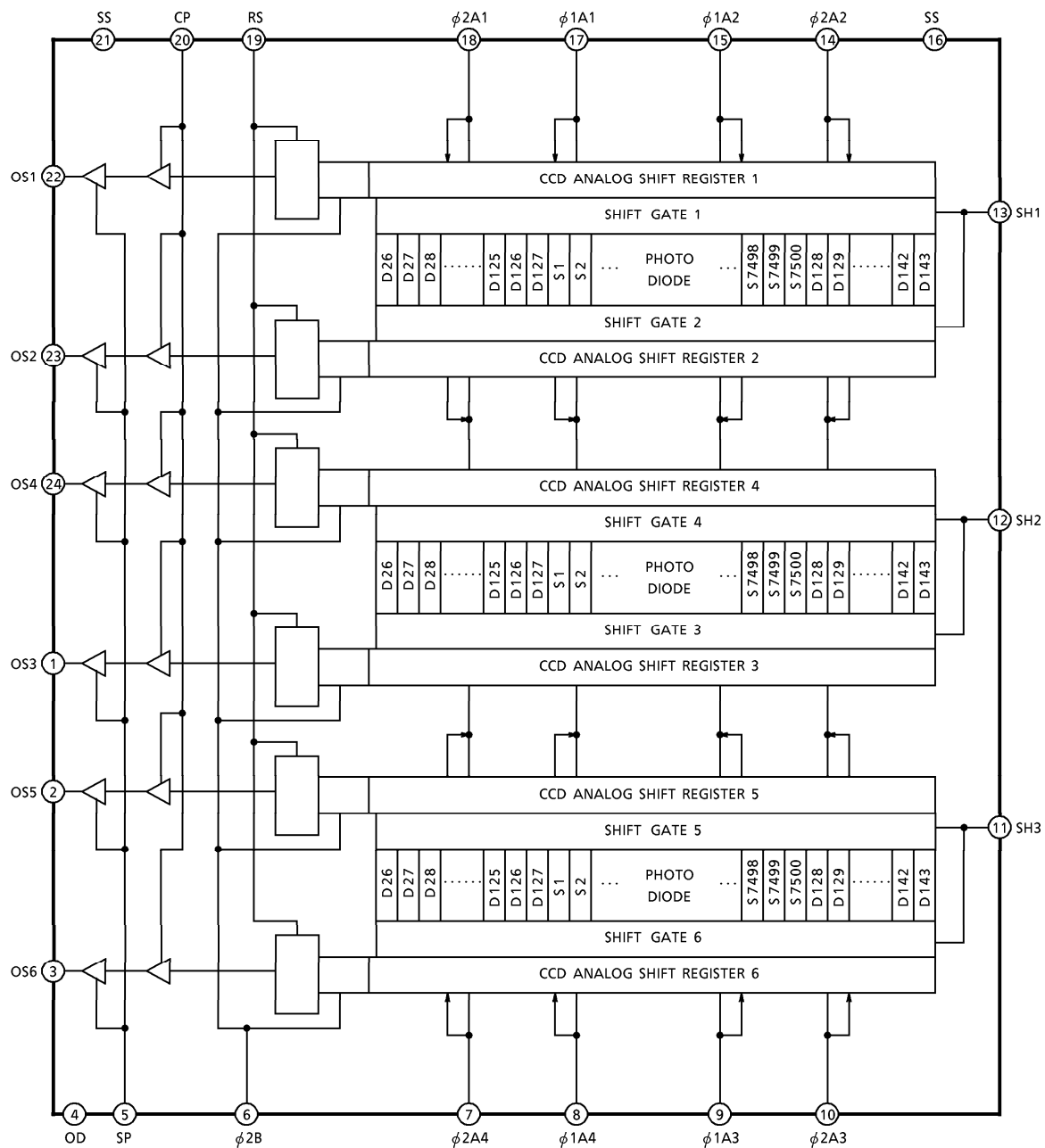

PIN NAMES

PIN No.	SYMBOL	NAME	PIN No.	SYMBOL	NAME
1	OS3	Signal Output 3 (Green)	13	SH1	Shift Gate 1
2	OS5	Signal Output 5 (Red)	14	ϕ 2A2	Clock 2 (Phase 2)
3	OS6	Signal Output 6 (Red)	15	ϕ 1A2	Clock 2 (Phase 1)
4	OD	Power	16	SS	Ground
5	SP	Sample and Hold Gate	17	ϕ 1A1	Clock 1 (Phase 1)
6	ϕ 2B	Final Stage Clock (phase 2)	18	ϕ 2A1	Clock 1 (Phase 2)
7	ϕ 2A4	Clock 4 (Phase 2)	19	RS	Reset Gate
8	ϕ 1A4	Clock 4 (Phase 1)	20	CP	Clamp Gate
9	ϕ 1A3	Clock 3 (Phase 1)	21	SS	Ground
10	ϕ 2A3	Clock 3 (Phase 2)	22	OS1	Signal Output 1 (Blue)
11	SH3	Shift Gate 3	23	OS2	Signal Output 2 (Blue)
12	SH2	Shift Gate 2	24	OS4	Signal Output 4 (Green)

OPTICAL / ELECTRICAL CHARACTERISTICS

($T_a = 25^\circ\text{C}$, $V_{OD} = 12\text{ V}$, $V_\phi = V_{SH} = V_{RS} = V_{CP} = 5\text{ V}$ (PULSE), $f_\phi = 1\text{ MHz}$,
LOAD RESISTANCE = $100\text{ k}\Omega$, t_{INT} (INTEGRATION TIME) = 10 ms ,
LIGHT SOURCE = A LIGHT SOURCE + CM500S FILTER ($t = 1.0\text{ mm}$))

CHARACTERISTIC		SYMBOL	MIN.	TYP.	MAX.	UNIT	NOTE
Responsivity	Red	R_R	3.7	5.3	6.9	V / lx·s	(Note 2)
	Green	R_G	5.3	7.7	10.1		
	Blue	R_B	2.0	2.9	3.8		
Photo Response Non Uniformity		PRNU (1)	—	10	20	%	(Note 3)
		PRNU (3)	—	3	12	mV	(Note 4)
Saturation Output Voltage		V_{SAT}	1.5	2.0	—	V	(Note 5)
Saturation Exposure		SE	0.15	0.26	—	lx·s	(Note 6)
Dark Signal Voltage		V_{DRK}	—	2.5	5	mV	(Note 7)
Dark Signal Non Uniformity		DSNU	—	8	12	mV	(Note 8)
DC Power Dissipation		PD	—	800	1200	mW	
Total Transfer Efficiency		TTE	92	—	—	%	
Output Impedance		Z_o	—	0.2	0.5	$\text{k}\Omega$	
DC Signal Output Voltage		V_{OS}	3.0	6.0	8.0	V	(Note 9)
Random Noise		$N_{D\sigma}$	—	1.3	—	mV	(Note 10)

- (Note 2) : Sensitivity is defined for each color of signal outputs average when the photosensitive surface is applied with the light of uniform illumination and uniform color temperature.
- (Note 3) : PRNU (1) is defined for each color on a single chip by the expressions below when the photosensitive surface is applied with the light of uniform illumination and uniform color temperature.

$$PRNU (1) = \frac{\Delta\bar{x}}{\bar{x}} \times 100 (\%)$$

Where \bar{x} is average of total signal outputs and $\Delta\bar{x}$ is the maximum deviation from \bar{x} .

- (Note 4) : PRNU (3) is defined as maximum voltage with next pixel, where measured 5% of SE (Typ.).
- (Note 5) : V_{SAT} is defined as minimum Saturation Output voltage of all effective pixels.

(Note 6) : Definition of SE : $SE = \frac{V_{SAT}}{R_G}$

- (Note 7) : V_{DRK} is defined as average dark signal voltage of all effective pixels.
- (Note 8) : DSNU is defined as different voltage between V_{DRK} and V_{MDK} , when V_{MDK} is maximum dark voltage.

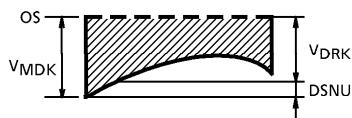

- (Note 9) : DC Signal Output Voltage is defined as follows :

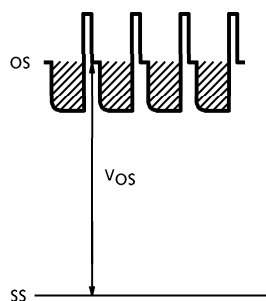

(Note 10) : Random noise is defined as the standard deviation (sigma) of the output level difference between two adjacent effective pixels under no illumination (i.e. dark condition) calculated by the following procedure.

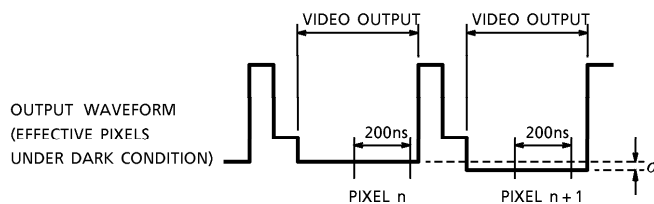

- 1) Two adjacent pixels (pixel n and n + 1) in one reading are fixed as measurement points.
- 2) Each of the output levels at video output periods averaged over 200 nanosecond period to get V_n and V_{n+1} .
- 3) V_{n+1} is subtracted from V_n to get ΔV .

$$\Delta V = V_n - V_{n+1}$$
- 4) The standard deviation of ΔV is calculated after procedure 2) and 3) are repeated 30 times (30 readings).

$$\overline{\Delta V} = \frac{1}{30} \sum_{i=1}^{30} |\Delta V_i| \quad \sigma = \sqrt{\frac{1}{30} \sum_{i=1}^{30} (|\Delta V_i| - \overline{\Delta V})^2}$$

- 5) Procedure 2), 3) and 4) are repeated 10 times to get 10 sigma values.

$$\overline{\sigma} = \frac{1}{10} \sum_{j=1}^{10} \sigma_j$$

- 6) $\overline{\sigma}$ value calculated using the above procedure is observed $\sqrt{2}$ times larger than that measured relative to the ground level. So we specify the random noise as follows.

$$\text{Random noise} = \frac{1}{\sqrt{2}} \overline{\sigma}$$

OPERATING CONDITION

CHARACTERISTIC		SYMBOL	MIN.	TYP.	MAX.	UNIT	NOTE
Clock Pulse Voltage	"H" Level	$V_{\phi A}$	4.5	5.0	5.5	V	
	"L" Level		0	—	0.5		
Final Stage Clock Pulse Voltage	"H" Level	$V_{\phi B}$	4.5	5.0	5.5	V	
	"L" Level		0	—	0.5		
Shift Pulse Voltage	"H" Level	V_{SH}	$V_{\phi A}{}^{\text{H}}-0.5$	$V_{\phi A}{}^{\text{H}}$	$V_{\phi A}{}^{\text{H}}$	V	(Note 11)
	"L" Level		0	—	0.5		
Reset Pulse Voltage	"H" Level	V_{RS}	4.5	5.0	5.5	V	
	"L" Level		0	—	0.5		
Clamp Pulse Voltage	"H" Level	V_{CP}	4.5	5.0	5.5	V	
	"L" Level		0	—	0.5		
Sample and Hold Pulse Voltage	"H" Level	V_{SP}	4.5	5.0	5.5	V	
	"L" Level		0	—	0.5		
Power Supply Voltage		V_{OD}	11.4	12.0	13.0	V	

(Note 11) : $V_{\phi A}{}^{\text{H}}$ means the high level voltage of $V_{\phi A}$ when SH pulse is high level.

CLOCK CHARACTERISTICS (Ta = 25°C)

CHARACTERISTIC	SYMBOL	MIN.	TYP.	MAX.	UNIT	NOTE
Clock Pulse Frequency	f_{ϕ}	—	1	20	MHz	
Reset Pulse Frequency	f_{RS}	—	1	20	MHz	
Clamp Pulse Frequency	f_{CP}	—	1	20	MHz	
Sample and Hold Pulse Frequency	f_{SP}	—	1	7.5	MHz	
Clock Capacitance (Note 12)	$C_{\phi A}$	—	350	—	pF	
Final Stage Clock Capacitance	$C_{\phi B}$	—	50	—	pF	
Reset Gate Capacitance	C_{RS}	—	50	—	pF	
Shift Gate Capacitance	C_{SH}	—	50	—	pF	
Clamp Gate Capacitance	C_{CP}	—	50	—	pF	
Sample and Hold Gate Capacitance	C_{SP}	—	50	—	pF	

(Note 12) : $V_{OD} = 12\text{ V}$

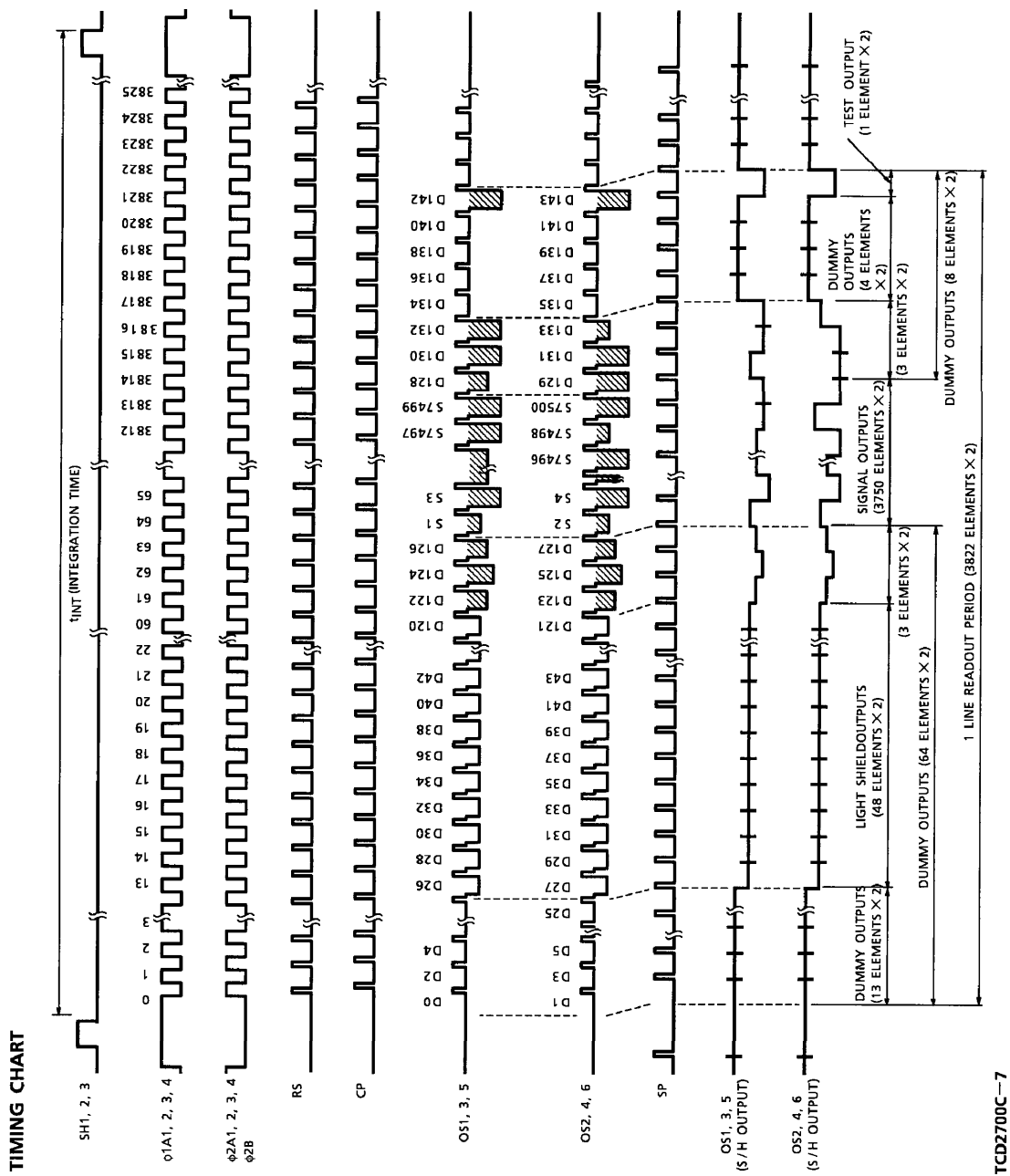

TCD2700C-7

TIMING REQUIREMENTS

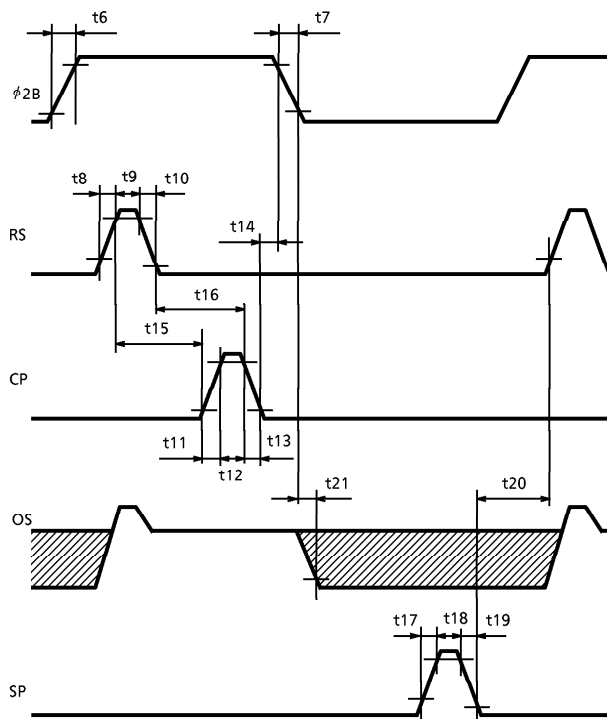
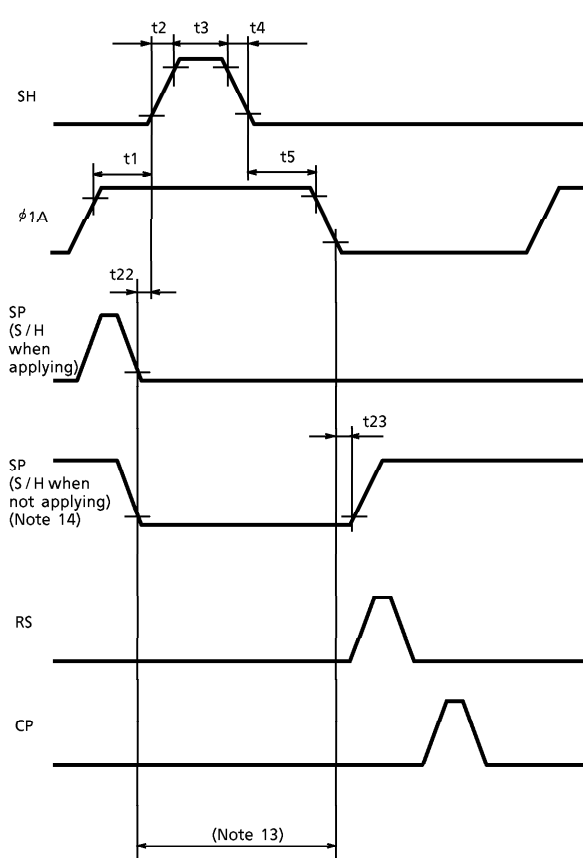

CROSS POINT

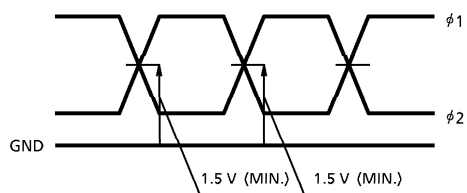

(Note 13) : Each SP, RS and CP pins put to Low level during this period.

(Note 14) : When you do not use a sample and hold circuit, put SP pin to High level except note 13 case.

TIMING REQUIREMENTS (Cont'd)

CHARACTERISTIC	SYMBOL	MIN.	TYP. (Note 15)	MAX.	UNIT
Pulse Timing of SH and ϕ 1A	t1	60	1000	—	ns
	t5	200	1000	—	
SH Pulse Rise Time, Fall Time	t2, t4	0	50	—	ns
SH Pulse Width	t3	1000	2000	—	ns
ϕ 1, ϕ 2 Pulse Rise Time, Fall Time	t6, t7	0	50	—	ns
RS Pulse Rise Time, Fall Time	t8, t10	0	20	—	ns
RS Pulse Width	t9	10	100	—	ns
CP Pulse Rise Time, Fall Time	t11, t13	0	20	—	ns
CP Pulse Width	t12	10	100	—	ns
Pulse Timing of ϕ 2B and CP	t14	5	40	—	ns
Pulse Timing of RS and CP	t15	0	100	—	ns
	t16	10	100	—	
SP Pulse Rise Time, Fall Time	t17, t19	0	20	—	ns
SP Pulse Width	t18	50	100	—	ns
Pulse Timing of RS and SP	t20	0	20	—	ns
Video Data Delay Time (Note 16)	t21	—	15	—	ns
Pulse Timing of SP and SH	t22	50	—	—	ns
	t23	0	—	—	

(Note 15) : TYP. is the case of $f_{RS} = 1$ MHz.

(Note 16) : Load Resistance is 100 k Ω .

TYPICAL SPECTRAL RESPONSE

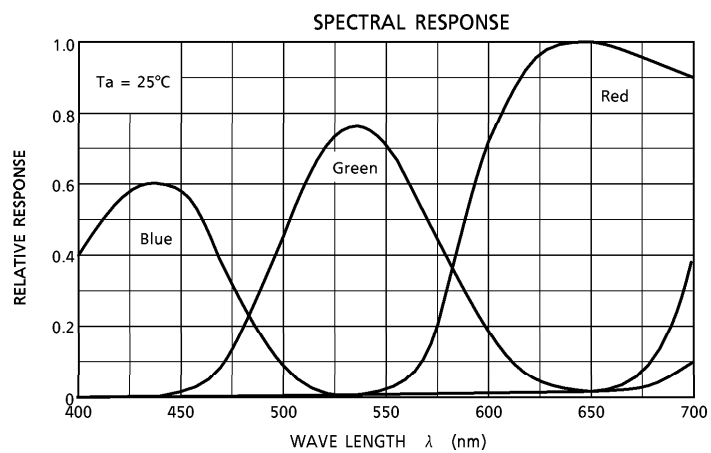

TYPICAL DRIVE CIRCUIT

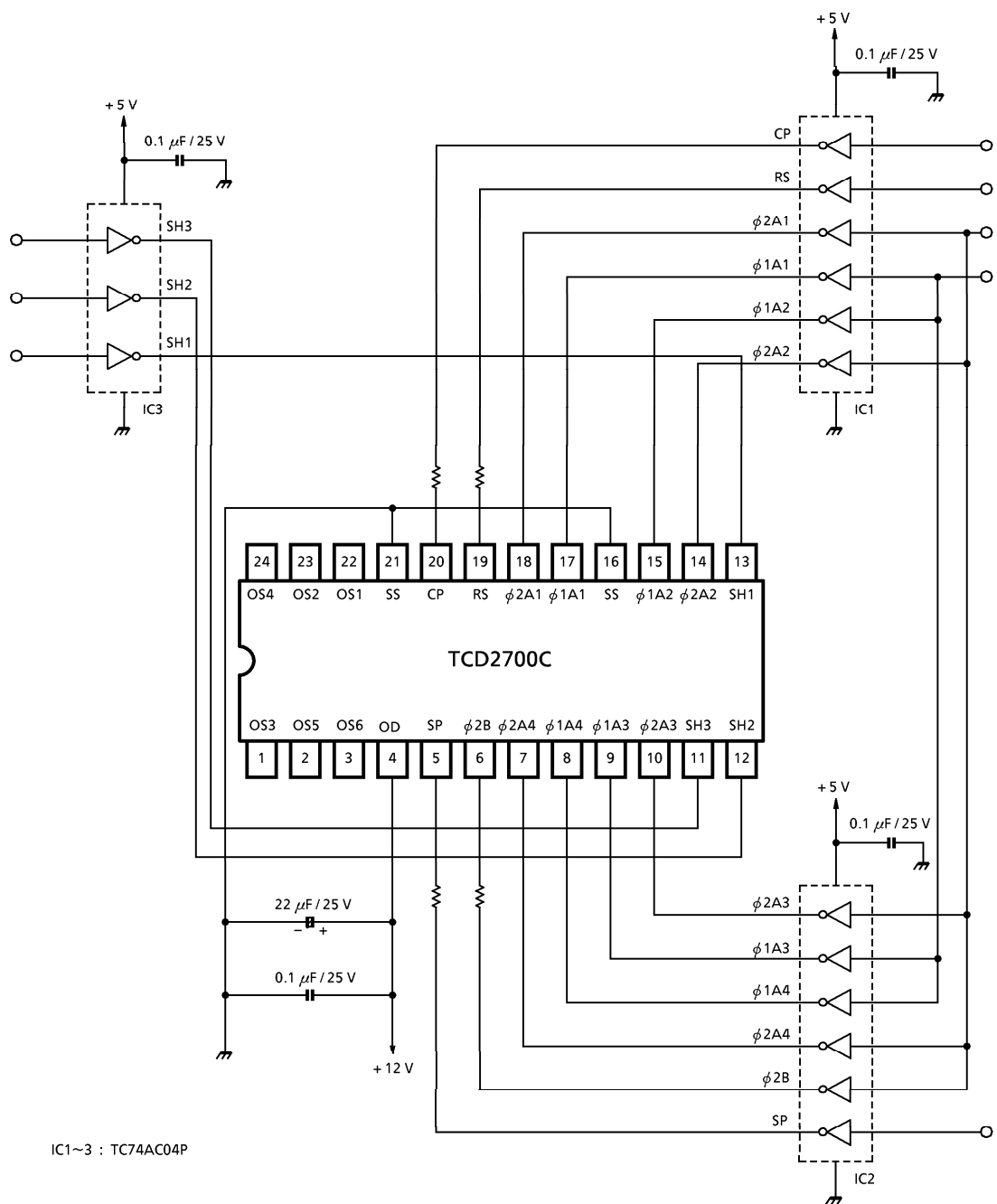

IC1~3 : TC74AC04P

TYPICAL DRIVE CIRCUIT

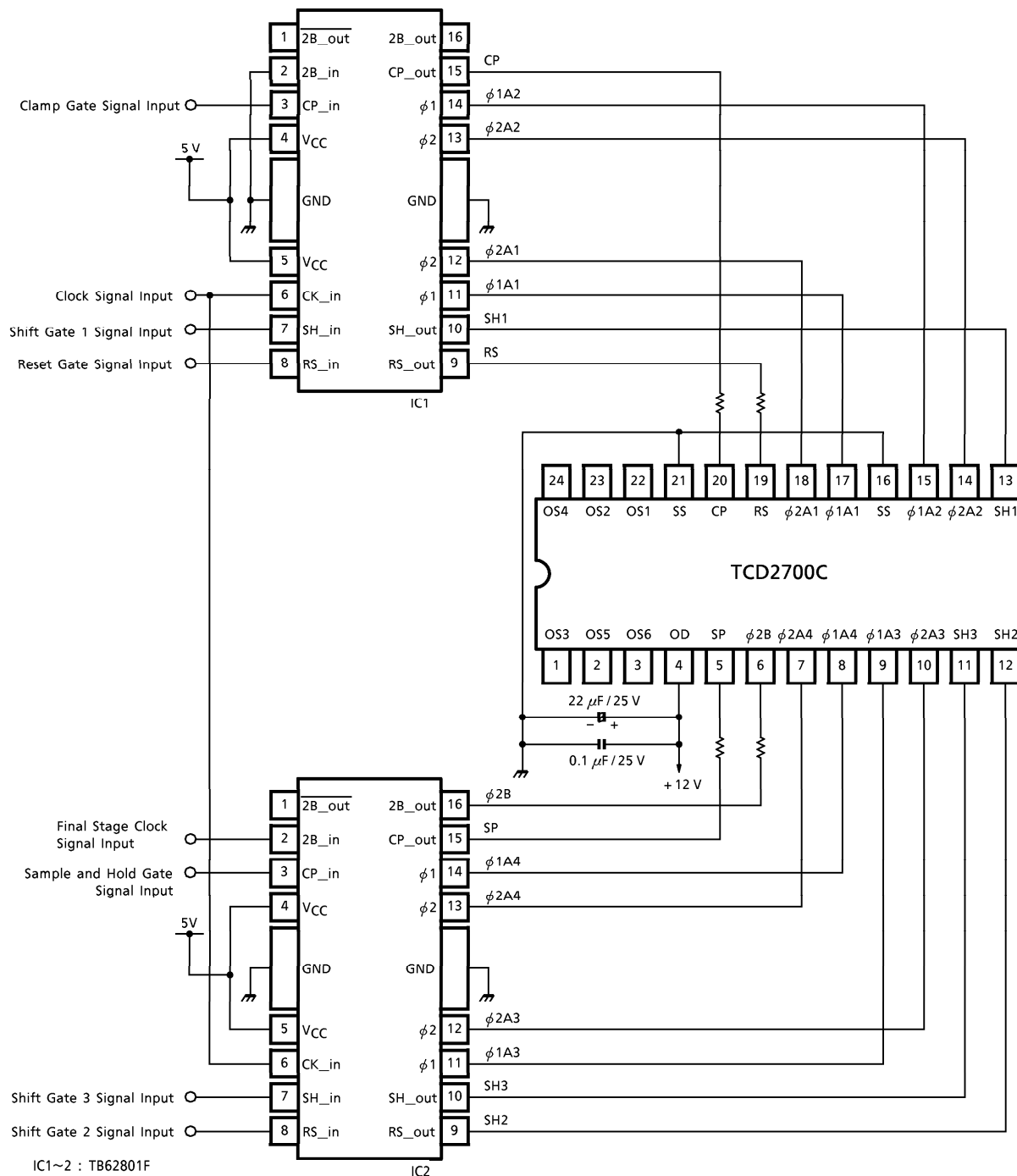

PRECAUTIONS FOR USE OF CCD IMAGE SENSOR**1. Static Electricity**

CCD Image Sensor is protected against static electricity, but inferior puncture mode device due to static electricity is sometimes detected. In handling the device, it is necessary to execute the following static electricity preventive measures, in order to prevent the trouble rate increase of the manufacturing system due to static electricity.

- a. Prevent the generation of static electricity due to friction by making the work with bare hands or by putting on cotton gloves and non-charging working clothes.
- b. Discharge the static electricity by providing earth plate or earth wire on the floor, door or stand of the work room.

- c. Ground the tools such as soldering iron, radio cutting plier or pincette.

It is not necessarily required to execute all precaution items for static electricity.

It is all right to mitigate the precautions by confirming that the trouble rate within the prescribed range.

2 Window Glass

As the dust and station on the glass window of the package will cause black flow on the picture, never fail to clean the glass surface before using. (Blow compressed vapor, and wipe off the dust, and dirt with soft cloth or paper slightly moistened with alcohol).

Fully take care for the handling of the device as the window glass will break or a strong friction is given to the window glass surface.

3. Incident Light

CCD image sensor has sensitivity in a wide range zone of light wave length, but its characteristics will sometimes widely change when used with long wave length input light outside the visual light zone.

OUTLINE DRAWING

WDIP24-C-600-2.54 (C)

Unit in mm

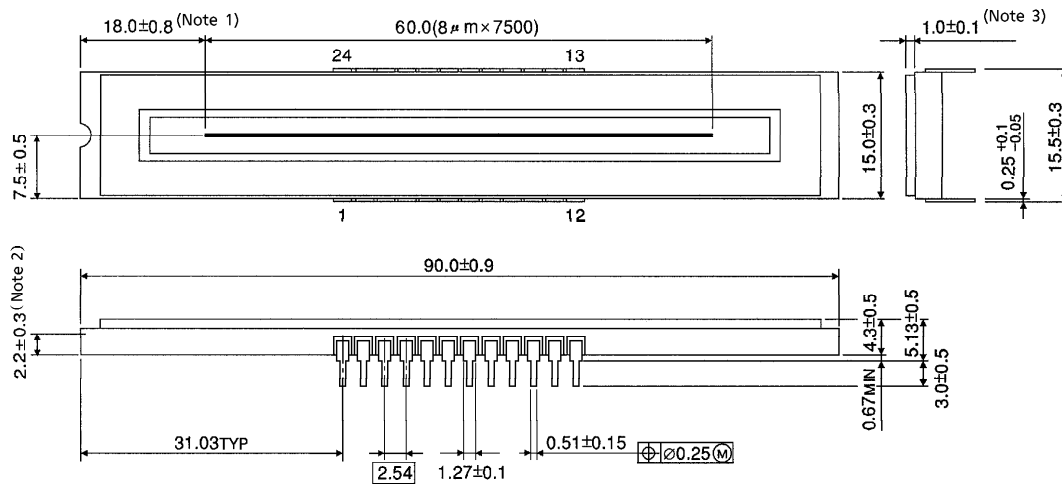

- (Note 1) : No. 1 SENSOR ELEMENT (S1) TO EDGE OF PACKAGE.
- (Note 2) : TOP OF CHIP TO BOTTOM OF PACKAGE.
- (Note 3) : GLASS THICKNES (n = 1.5)

Weight : 17.1 g (Typ.)