

DS3662 Quad High Speed Trapezoidal™ Bus Transceiver

General Description

The DS3662 is a quad high speed Schottky bus transceiver intended for use with terminated 120Ω impedance lines. It is specifically designed to reduce noise in unbalanced transmission systems. The open collector drivers generate precise trapezoidal waveforms with rise and fall times of 15 ns (typical), which are relatively independent of capacitive loading conditions on the outputs. This reduces noise coupling to the adjacent lines without any appreciable impact on the maximum data rate obtainable with high speed bus transceivers. In addition, the receivers use a low pass filter in conjunction with a high speed comparator, to further enhance the noise immunity. Tightly controlled threshold levels on the receiver provide equal rejection to both negative and positive going noise pulses on the bus.

The external termination is intended to be a 180Ω resistor from the bus to 5V logic supply, together with a 390Ω resistor from the bus to ground. The bus can be terminated at one or both ends. A two input NOR gate is provided to disable all drivers in a package simultaneously.

Features

- Pin to pin functional replacement for DS8641
- Guaranteed AC specifications on noise immunity and propagation delay over the specified temperature and supply voltage range
- Temperature insensitive receiver thresholds track bus logic level
- Trapezoidal bus waveforms reduce noise coupling to adjacent lines
- Precision receiver thresholds provide maximum noise immunity and symmetrical response to positive and negative going pulses
- Open collector driver output allows wire-OR connection
- High speed Schottky technology
- 15 μA typical bus termination current with normal V_{CC} or with $V_{CC} = 0V$
- Glitch free power up/down protection on the driver output
- TTL compatible driver and disable inputs, and receiver outputs

Block and Connection Diagram

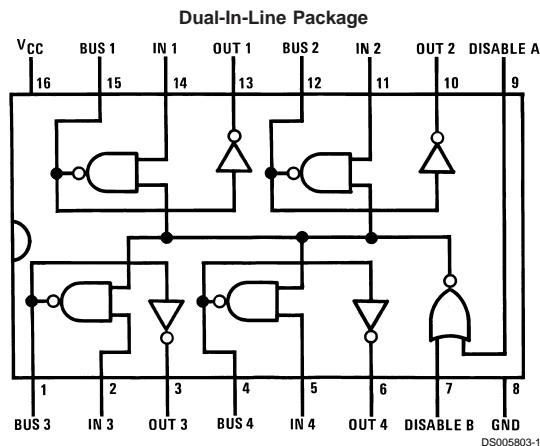

Trapezoidal™ is a trademark of National Semiconductor Corp.

Absolute Maximum Ratings (Note 2)

If Military/Aerospace specified devices are required, please contact the National Semiconductor Sales Office/Distributors for availability and specifications.

Supply Voltage	7V
Input and Output Voltage	5.5V
Storage Temperature Range	-65°C to +150°C
Maximum Power Dissipation (Note 1) at 25°C	
Cavity Package	1509 mW
Molded Package	1476 mW

Lead Temperature (Soldering, 4 sec.)

260°C

Recommended Operating Conditions

	Min	Max	Units
Supply Voltage (V_{CC})	4.75	5.25	V
Temperature Range (T_A)	0	70	°C

Note 1: Derate cavity package 10.1 mW/°C above 25°C; derate molded package 11.8 mW/°C above 25°C.

Electrical Characteristics (Notes 3, 4)

Symbol	Parameter	Conditions	Min	Typ	Max	Units
DRIVER AND DISABLE INPUTS						
V_{IH}	Logical "1" Input Voltage		2.0			V
V_{IL}	Logical "0" Input Voltage				0.8	V
I_I	Logical "1" Input Current	$V_{IN} = 5.5V$			1	mA
I_{IH}	Logical "1" Input Current	$V_{IN} = 2.4V$			40	µA
I_{IL}	Logical "0" Input Current	$V_{IN} = 0.4V$		-1	-1.6	mA
V_{CL}	Input Diode Clamp Voltage	$I_{CLAMP} = -12\text{ mA}$		-0.8	-1.5	V
DRIVER OUTPUT/RECEIVER INPUT						
V_{OLB}	Low Level Bus Voltage	$V_{DIS} = 0.8V, V_{IN} = 2V, I_{BUS} = 100\text{ mA}$		0.6	0.9	V
I_{IHB}	Maximum Bus Current	$V_{IN} = 0.8V, V_{BUS} = 4V, V_{CC} = 5.25V$		10	100	µA
I_{ILB}	Maximum Bus Current	$V_{IN} = 0.8V, V_{BUS} = 4V, V_{CC} = 0V$			100	µA
V_{IH}	High Level Receiver Threshold	$V_{IN} = 0.8V, V_{OL} = 16\text{ mA}$	1.90	1.70		V
V_{IL}	Low Level Receiver Threshold	$V_{IN} = 0.8V, I_{OH} = -400\text{ µA}$		1.70	1.50	V
RECEIVER OUTPUT						
V_{OH}	Logical "1" Output Voltage	$V_{IN} = 0.8V, V_{BUS} = 0.5V, I_{OH} = -400\text{ µA}$	2.4	3.2		V
V_{OL}	Logical "0" Output Voltage	$V_{IN} = 0.8V, V_{BUS} = 4V, I_{OL} = 16\text{ mA}$		0.35	0.5	V
I_{OS}	Output Short Circuit Current	$V_{DIS} = 0.8V, V_{IN} = 0.8V, V_{BUS} = 0.5V, V_{OS} = 0V, V_{CC} = 5.25V, (\text{Note } 5)$	-40	-70	-100	mA
I_{CC}	Supply Current	$V_{DIS} = 0V, V_{IN} = 2V$		50	90	mA

Switching Characteristics (Notes 3, 4)

Symbol	Parameter	Conditions	Min	Typ	Max	Units
PROPAGATION DELAYS						
t_{PLHD}	Disable to Bus "1"	<i>Figure 1</i>		25	35	ns
t_{PHLD}	Disable to Bus "0"			25	35	ns
t_{PLHB}	Driver Input to Bus "1"	<i>Figure 2</i>		20	30	ns
t_{PHLB}	Driver Input to Bus "0"			20	30	ns
t_{PLHR}	Bus to Logical "1" Receiver Output	<i>Figure 3</i>		25	40	ns
t_{PHLR}	Bus to Logical "0" Receiver Output			25	40	ns
NOISE IMMUNITY						
t_{rB}, t_{fB}	Rise and Fall Times (10%–90%) of the Driver Output	<i>Figure 2</i>	10	15	20	ns
t_{nR}	Receiver Noise Rejection Pulse Width	No Response at Receiver Output as per <i>Figure 4</i>		20	10	ns

Note 2: "Absolute Maximum Ratings" are those values beyond which the safety of the device cannot be guaranteed. They are not meant to imply that the devices should be operated at these limits. The tables of "Electrical Characteristics" and "Recommended Operating Conditions" provide conditions for actual device operation.

Note 3: Unless otherwise specified min/max limits apply across the supply and temperature range listed in the table of "Recommended Operating Conditions". All typical values are for $T_A = 25^\circ\text{C}$ and $V_{CC} = 5V$.

Note 4: All currents into device pins shown as positive, out of device pins as negative, all voltages referenced to ground unless otherwise noted. All values shown as max or min on absolute value basis.

Switching Characteristics (Notes 3, 4) (Continued)

Note 5: Only one output at a time should be shorted.

AC Test Circuits and Switching Waveforms

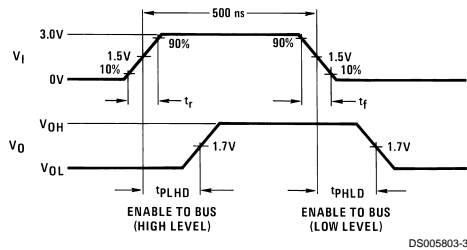
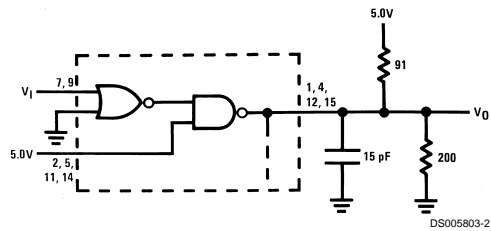

Note: $t_r = t_f = 2.5$ ns. Pulse width = 500 ns measured between 1.5V levels. $f = 1$ MHz.

FIGURE 1. Disable Delays

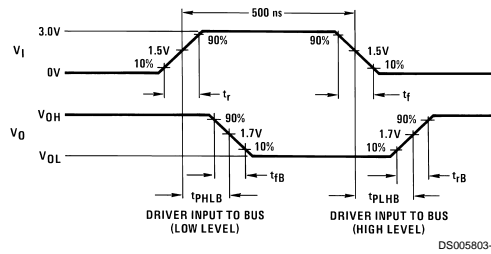
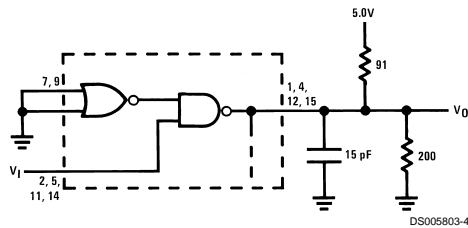

Note: $t_r = t_f = 2.5$ ns. Pulse width = 500 ns measured between 1.5V levels. $f = 1$ MHz.

FIGURE 2. Driver Propagation Delays

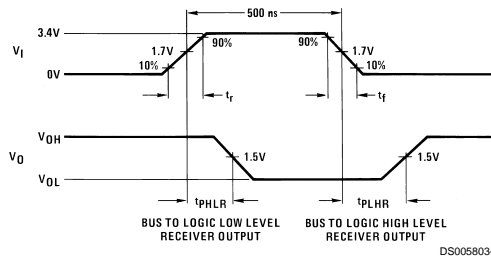
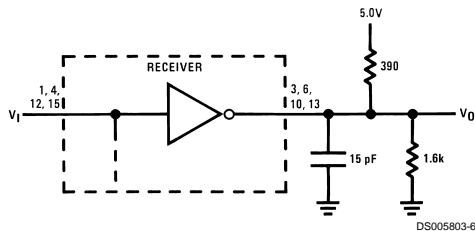

Note: $t_r = t_f = 15$ ns. Pulse width = 500 ns measured between 1.7V levels. $f = 1$ MHz.

FIGURE 3. Receiver Propagation Delays

AC Test Circuits and Switching Waveforms (Continued)

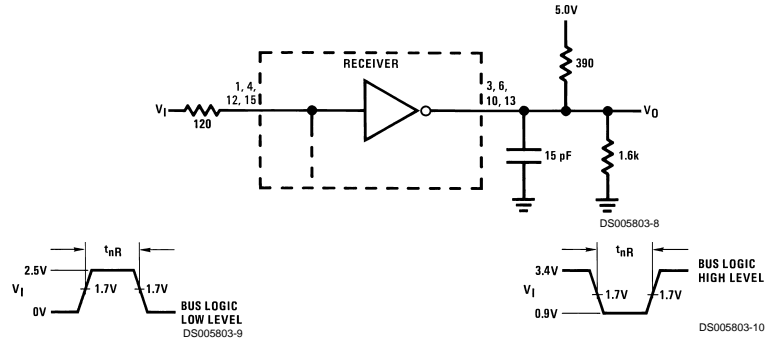

$t_r = t_f = 2.5 \text{ ns}$

$t_r = t_f = 2.5 \text{ ns}$

(a) Receiver Output (V_o) to Remain Greater than 2.2V

(b) Receiver Output (V_o) to Remain Less than 0.7V

FIGURE 4. Receiver Noise Immunity: "No Response at Output" Input Waveforms

Typical Application

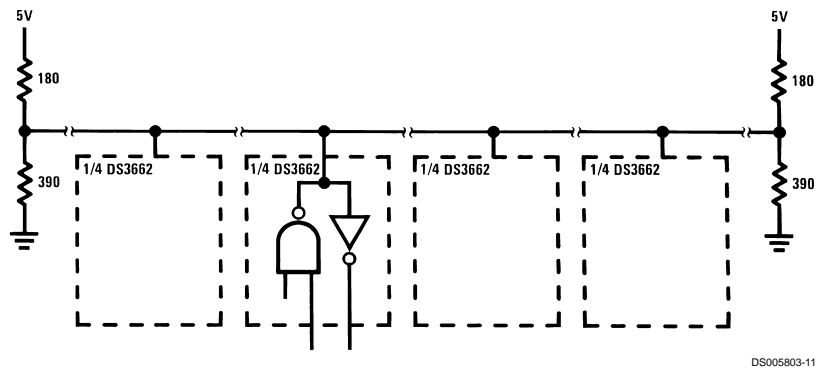

DS005803-11

Physical Dimensions inches (millimeters) unless otherwise noted

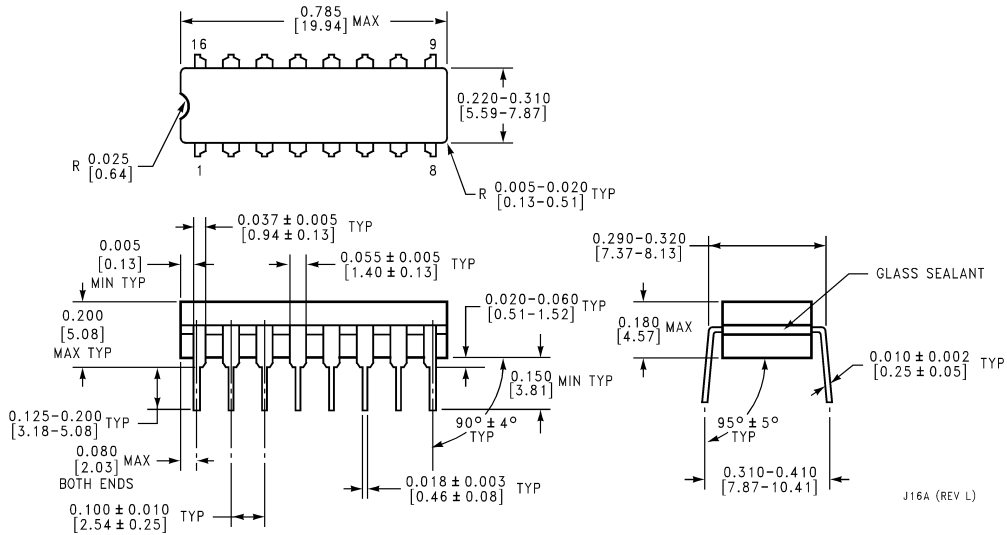

Ceramic Dual-In-Line Package (J)
Order Number DS3662J
NS Package Number J16A

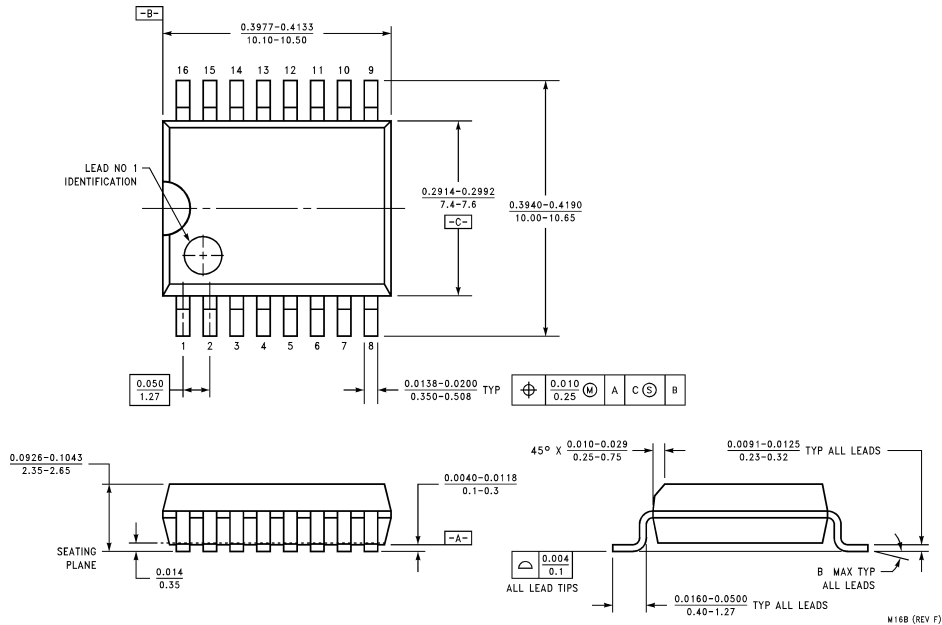

16-Lead Molded Small Outline Package (M)
Order Number DS3662WM
NS Package Number M16B

Physical Dimensions inches (millimeters) unless otherwise noted (Continued)

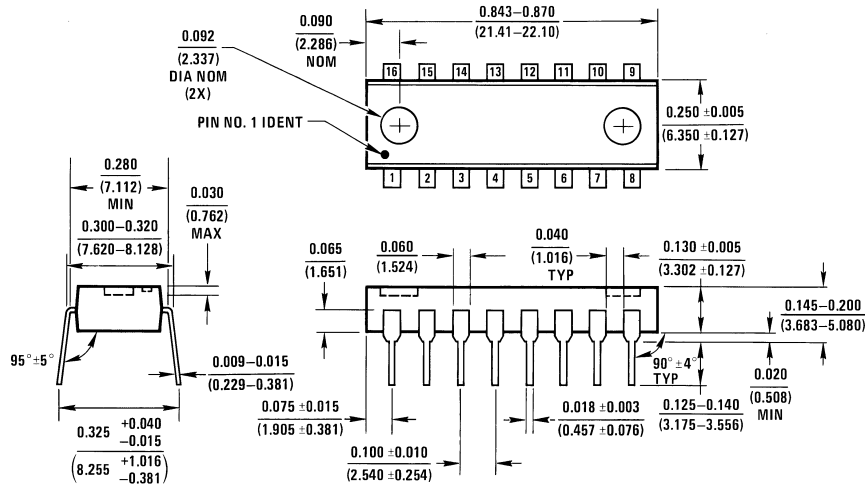

N16A (REV E)

Molded Dual-In-Line Package (N)
Order Number DS3662N
NS Package Number N16A

LIFE SUPPORT POLICY

NATIONAL'S PRODUCTS ARE NOT AUTHORIZED FOR USE AS CRITICAL COMPONENTS IN LIFE SUPPORT DEVICES OR SYSTEMS WITHOUT THE EXPRESS WRITTEN APPROVAL OF THE PRESIDENT AND GENERAL COUNSEL OF NATIONAL SEMICONDUCTOR CORPORATION. As used herein:

1. Life support devices or systems are devices or systems which, (a) are intended for surgical implant into the body, or (b) support or sustain life, and whose failure to perform when properly used in accordance with instructions for use provided in the labeling, can be reasonably expected to result in a significant injury to the user.
2. A critical component is any component of a life support device or system whose failure to perform can be reasonably expected to cause the failure of the life support device or system, or to affect its safety or effectiveness.



National Semiconductor Corporation
Americas
Tel: 1-800-272-9959
Fax: 1-800-737-7018
Email: support@nsc.com

National Semiconductor Europe
Fax: +49 (0) 1 80-530 85 86
Email: europe.support@nsc.com
Deutsch Tel: +49 (0) 1 80-530 85 85
English Tel: +49 (0) 1 80-532 78 32
Français Tel: +49 (0) 1 80-532 93 58
Italiano Tel: +49 (0) 1 80-534 16 80

National Semiconductor Asia Pacific Customer Response Group
Tel: 65-2544466
Fax: 65-2504466
Email: sea.support@nsc.com

National Semiconductor Japan Ltd.
Tel: 81-3-5639-7560
Fax: 81-3-5639-7507

www.national.com

National does not assume any responsibility for use of any circuitry described, no circuit patent licenses are implied and National reserves the right at any time without notice to change said circuitry and specifications.