

---

# HA17747/P

## Dual Operational Amplifier

# HITACHI

---

### Description

The HA17747/P is a dual internal phase compensation high-performance operational amplifier, that is appropriate for use in a wide range of applications in the test and control fields.

### Features

- High voltage gain : 106 dB (Typ)
- Wide output amplitude :  $\pm 13$  V (Typ) (at  $R_L \geq 2$  k $\Omega$ )
- Shorted output protection
- Adjustable offset voltage
- Internal phase compensation

### Ordering Information

Type No.	Application	Package
HA17747P	Industrial use	DP-14
HA17747	Commercial use	

### Pin Arrangement

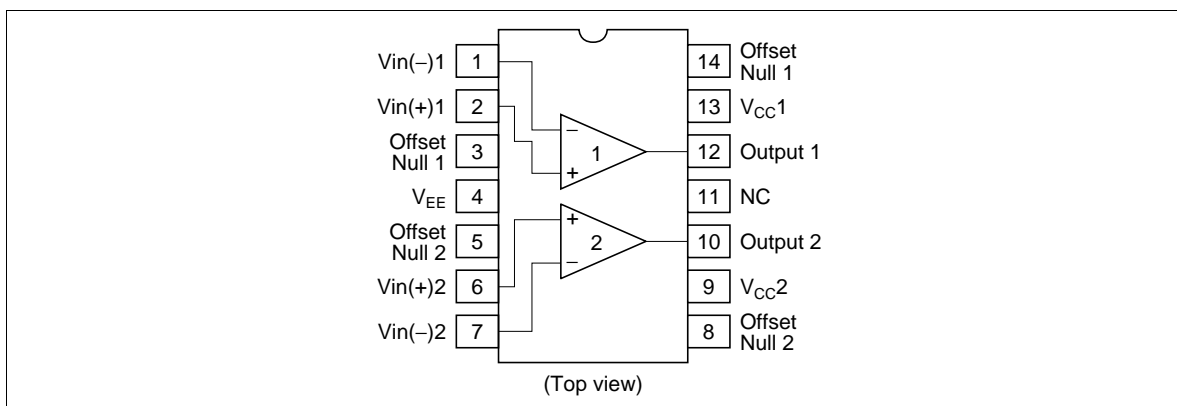

# HA17747/P

## Circuit Structure

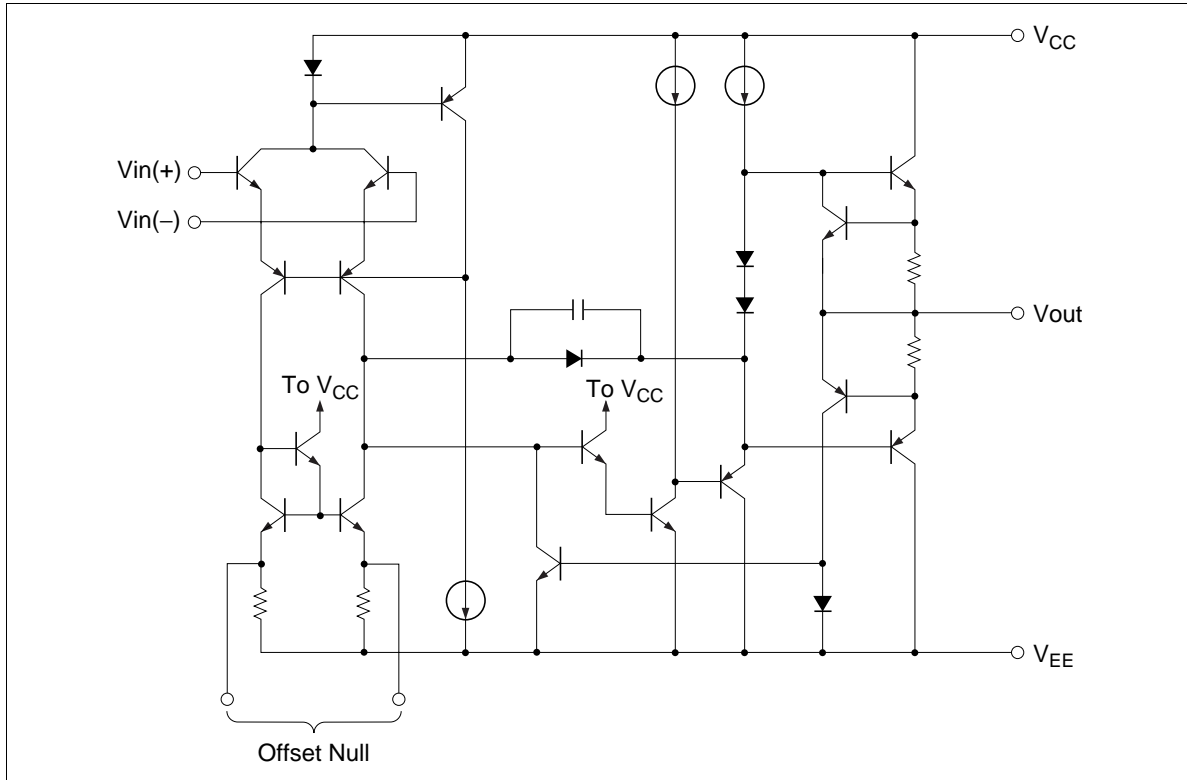

## Absolute Maximum Ratings (Ta = 25°C)

Item	Symbol	Ratings		Unit
		HA17747P	HA17747	
Power-supply voltage	V <sub>CC</sub>	+18	+18	V
	V <sub>EE</sub>	-18	-18	V
Input voltage	V <sub>in</sub>	±15 *1	±15 *1	V
Differential input voltage	V <sub>in(diff)</sub>	±30	±30	V
Offset adjustment pin - V <sub>EE</sub> voltage	V <sub>OFF</sub> - V <sub>EE</sub>	±0.5	±0.5	V
Allowable power dissipation	P <sub>T</sub>	670 *2	670 *2	mW
Operating temperature	Topr	-20 to +75	-20 to +75	°C
Storage temperature	Tstg	-55 to +125	-55 to +125	°C

Notes: 1. When the power-supply voltage is less than ±15 V, the input voltage must fall within the power-supply voltage range.

2. These are the allowable values up to Ta = 45°C. Above that temperature, derate by 8.3 mW/°C.

**HITACHI**

**Electrical Characteristics**

**Electrical Characteristics-1** ( $V_{CC} = -V_{EE} = 15\text{ V}$ ,  $T_a = 25^\circ\text{C}$ )

Item	Symbol	Min	Typ	Max	Unit	Test Condition
Input offset voltage	$V_{IO}$	—	1.0	6.0	mV	$R_s \leq 10\text{ k}\Omega$
Input offset current	$I_{IO}$	—	20	200	nA	
Input bias current	$I_{IB}$	—	80	500	nA	
Voltage gain	$A_{VD}$	88	106	—	dB	$R_L \geq 2\text{ k}\Omega$ , $V_{out} = \pm 10\text{ V}$
Supply current	$I_{CC}$	—	1.7	2.8	mA	No load
Power dissipation	$P_d$	—	50	85	mW	(per channel rating)
Input resistance	$R_{in}$	0.3	2.0	—	M $\Omega$	
Input capacitance	$C_{in}$	—	1.4	—	pF	
Output resistance	$R_{out}$	—	75	—	$\Omega$	
Slew rate	SR	—	1.0	—	V/ $\mu\text{s}$	$R_L \geq 2\text{ k}\Omega$
Rise time	$t_r$	—	0.3	—	$\mu\text{s}$	$V_{in} = -20\text{ mV}$ ,
Overshoot	$V_{over}$	—	5.0	—	%	$R_L = 2\text{ k}\Omega$ , $C_L = 100\text{ pF}$
Input offset voltage adjustment range	$\Delta V_{IO(adj)}$	—	$\pm 15$	—	mV	
Output shorted current	$I_{OS}$	—	25	—	mA	
Channel separation	CS	—	120	—	dB	

**Electrical Characteristics-2** ( $V_{CC} = -V_{EE} = 15\text{ V}$ ,  $T_a = -20\text{ to }+75^\circ\text{C}$ )

Item	Symbol	Min	Typ	Max	Unit	Test Condition
Input offset voltage	$V_{IO}$	—	1.0	9.0	mV	$R_s \leq 10\text{ k}\Omega$
Input offset current	$I_{IO}$	—	20	400	nA	
Input bias current	$I_{IB}$	—	80	1,100	nA	
Power-supply rejection ratio	$\Delta V_{IO}/\Delta V_{CC}$	—	30	150	$\mu\text{V/V}$	$R_s \leq 10\text{ k}\Omega$
	$\Delta V_{IO}/\Delta V_{EE}$	—	30	150	$\mu\text{V/V}$	$R_s \leq 10\text{ k}\Omega$
Voltage gain	$A_{VD}$	80	—	—	dB	$R_L \geq 2\text{ k}\Omega$ , $V_{out} = \pm 10\text{ V}$
Common-mode rejection ratio	CMR	70	90	—	dB	$R_s \leq 10\text{ k}\Omega$
Common-mode input voltage range	$V_{CM}$	$\pm 12$	$\pm 13$	—	V	
Maximum output voltage amplitude	$V_{OP-P}$	$\pm 12$	$\pm 14$	—	V	$R_L \geq 10\text{ k}\Omega$
		$\pm 10$	$\pm 13$	—	V	$R_L \geq 2\text{ k}\Omega$
Supply current	$I_{CC}$	—	2.1	3.7	mA	No load
Power dissipation	$P_d$	—	65	110	mW	(per channel rating)

# HA17747/P

## Package Dimensions

Unit: mm

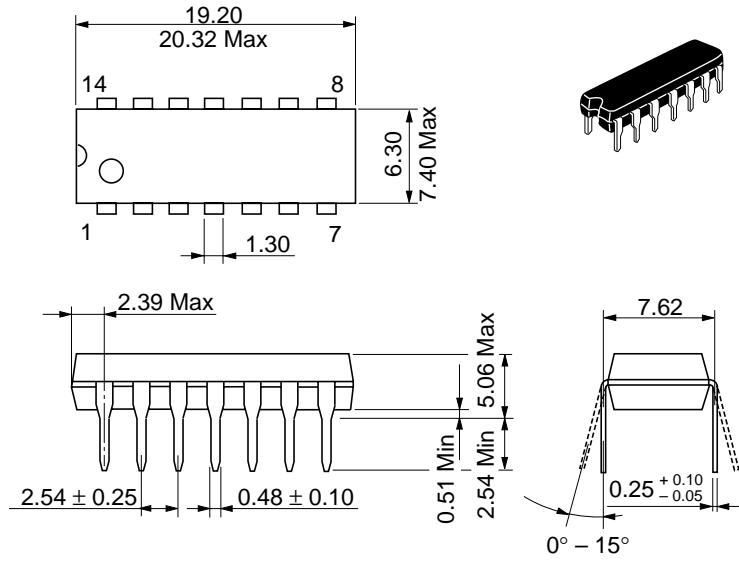

Hitachi Code	DP-14
JEDEC	Conforms
EIAJ	Conforms
Mass (reference value)	0.97 g

**HITACHI**

## Cautions

1. Hitachi neither warrants nor grants licenses of any rights of Hitachi's or any third party's patent, copyright, trademark, or other intellectual property rights for information contained in this document. Hitachi bears no responsibility for problems that may arise with third party's rights, including intellectual property rights, in connection with use of the information contained in this document.
2. Products and product specifications may be subject to change without notice. Confirm that you have received the latest product standards or specifications before final design, purchase or use.
3. Hitachi makes every attempt to ensure that its products are of high quality and reliability. However, contact Hitachi's sales office before using the product in an application that demands especially high quality and reliability or where its failure or malfunction may directly threaten human life or cause risk of bodily injury, such as aerospace, aeronautics, nuclear power, combustion control, transportation, traffic, safety equipment or medical equipment for life support.
4. Design your application so that the product is used within the ranges guaranteed by Hitachi particularly for maximum rating, operating supply voltage range, heat radiation characteristics, installation conditions and other characteristics. Hitachi bears no responsibility for failure or damage when used beyond the guaranteed ranges. Even within the guaranteed ranges, consider normally foreseeable failure rates or failure modes in semiconductor devices and employ systemic measures such as fail-safes, so that the equipment incorporating Hitachi product does not cause bodily injury, fire or other consequential damage due to operation of the Hitachi product.
5. This product is not designed to be radiation resistant.
6. No one is permitted to reproduce or duplicate, in any form, the whole or part of this document without written approval from Hitachi.
7. Contact Hitachi's sales office for any questions regarding this document or Hitachi semiconductor products.

---



---

# HITACHI

## Hitachi, Ltd.

Semiconductor & Integrated Circuits.  
 Nippon Bldg., 2-6-2, Ohte-machi, Chiyoda-ku, Tokyo 100-0004, Japan  
 Tel: Tokyo (03) 3270-2111 Fax: (03) 3270-5109

URL      North America      : <http://semiconductor.hitachi.com/>  
              Europe                : <http://www.hitachi-eu.com/hel/ecg>  
              Asia (Singapore)      : <http://www.has.hitachi.com.sg/grp3/sicd/index.htm>  
              Asia (Taiwan)            : [http://www.hitachi.com.tw/E/Product/SICD\\_Frame.htm](http://www.hitachi.com.tw/E/Product/SICD_Frame.htm)  
              Asia (HongKong)        : <http://www.hitachi.com.hk/eng/bo/grp3/index.htm>  
              Japan                        : <http://www.hitachi.co.jp/Sicd/indx.htm>

### For further information write to:

Hitachi Semiconductor  
 (America) Inc.  
 179 East Tasman Drive,  
 San Jose, CA 95134  
 Tel: <1> (408) 433-1990  
 Fax: <1> (408) 433-0223

Hitachi Europe GmbH  
 Electronic components Group  
 Dornacher Straße 3  
 D-85622 Feldkirchen, Munich  
 Germany  
 Tel: <49> (89) 9 9180-0  
 Fax: <49> (89) 9 29 30 00

Hitachi Europe Ltd.  
 Electronic Components Group.  
 Whitebrook Park  
 Lower Cookham Road  
 Maidenhead  
 Berkshire SL6 8YA, United Kingdom  
 Tel: <44> (1628) 585000  
 Fax: <44> (1628) 778322

Hitachi Asia Pte. Ltd.  
 16 Collyer Quay #20-00  
 Hitachi Tower  
 Singapore 049318  
 Tel: 535-2100  
 Fax: 535-1533

Hitachi Asia Ltd.  
 Taipei Branch Office  
 3F, Hung Kuo Building, No.167,  
 Tun-Hwa North Road, Taipei (105)  
 Tel: <886> (2) 2718-3666  
 Fax: <886> (2) 2718-8180

Hitachi Asia (Hong Kong) Ltd.  
 Group III (Electronic Components)  
 7/F., North Tower, World Finance Centre,  
 Harbour City, Canton Road, Tsim Sha Tsui,  
 Kowloon, Hong Kong  
 Tel: <852> (2) 735 9218  
 Fax: <852> (2) 730 0281  
 Telex: 40815 HITEC HX

Copyright ' Hitachi, Ltd., 1998. All rights reserved. Printed in Japan.

**HITACHI**