

FW330 Power Modules: dc-dc Converters; 36 to 75 Vdc Input, 3.6, 3.3, 2.5, 2.0, or 1.8 Vdc Output; 180 W to 330 W



The FW330 Power Modules use advanced, surface-mount technology and deliver high-quality, compact, dc-dc conversion at an economical price.

Applications

- Redundant and distributed power architectures
- Computer equipment
- Communications equipment

Options

- Heat sinks for improved thermal management
- Choice of primary remote on/off logic
- Delayed current-limit shutdown
- Temperature monitor signal

Description

The FW330S3R671, FW330F1, FW330G1, FW330D1, and FW330Y1 Power Modules are dc-dc converters that operate over an input voltage range of 36 Vdc to 75 Vdc and provide a precisely regulated dc output. The outputs are fully isolated from the inputs, allowing versatile polarity configurations and grounding connections. The modules have maximum power ratings from 180 W to 330 W at a typical full-load efficiency of 79% only for Fs.

Two or more modules may be paralleled with forced load sharing for redundant or enhanced power applications. The package, which mounts on a printed-circuit board, accommodates a heat sink for high-temperature applications. Listed above are the enhanced features for convenience and flexibility in redundant and/or distributed power applications.

* ISO is a registered trademark of the International Organization for Standardization.

† UL is a registered trademark of Underwriters Laboratories, Inc.

‡ CSA is a registered trademark of Canadian Standards Assn.

§ VDE is a trademark of Verband Deutscher Elektrotechniker e.V.

** This product is intended for integration into end-use equipment. All the required procedures for CE marking of end-use equipment should be followed. (The CE mark is placed on selected products.)

Features

- Size: 61.0 mm x 116.8 mm x 14.5 mm (2.40 in. x 4.60 in. x 0.57 in.)
- High efficiency: 79% typical (only for Fs)
- Parallel operation with forced load sharing
- Parallelable with FW300F1 and JFW050-150F1 (only for FW330F1, -T, -33T)
- Output voltage set-point adjustment (trim)
- Overtemperature protection with thermal warning signal
- Anti-rollback circuit
- Synchronization
- Power good signal
- Output current monitor
- Output overvoltage and overcurrent protection
- Overcurrent and overvoltage set-point adjustment
- Constant frequency, case ground pin
- Remote sense
- Primary and secondary remote on/off
- Short-circuit protection
- ISO* 9001 Certified manufacturing facilities
- UL†1950 Recognized, CSA‡ C22.2 No. 950-95 Certified, and VDE§ 0805 (EN60950, IEC950) Licensed
- CE mark meets 73/23/EEC and 93/68/EEC directives**

Absolute Maximum Ratings

Stresses in excess of the absolute maximum ratings can cause permanent damage to the device. These are absolute stress ratings only. Functional operation of the device is not implied at these or any other conditions in excess of those given in the operations sections of the data sheet. Exposure to absolute maximum ratings for extended periods can adversely affect device reliability.

Parameter	Symbol	Min	Max	Unit
Input Voltage: Continuous	V_I	—	80	Vdc
Transient (100 ms)	$V_{I, trans}$	—	100	Vdc
I/O Isolation Voltage (for 1 minute)	—	—	1500	V
Operating Case Temperature (See Thermal Considerations section and Figure 29).	T_C	-40	100	°C
Storage Temperature	T_{stg}	-55	125	°C

Electrical Specifications

Unless otherwise indicated, specifications apply over all operating input voltage, resistive load, and temperature conditions.

Table 1. Input Specifications

Parameter	Symbol	Min	Typ	Max	Unit
Operating Input Voltage	V_I	36	48	75	Vdc
Maximum Input Current ($V_I = 0$ V to 75 V):					
FW330S3R671-56	$I_{I, max}$	—	—	16.3	A
FW330F1, -T, -33T	$I_{I, max}$	—	—	13.4	A
FW330G1, 71-56T	$I_{I, max}$	—	—	10.8	A
FW330D1	$I_{I, max}$	—	—	8.9	A
FW330Y1-33T	$I_{I, max}$	—	—	8.3	A
Maximum Input Current ($V_I = 36$ V to 75 V):					
FW330S3R671-56	$I_{I, max}$	—	—	11.8	A
FW330F1, -T, -33T	$I_{I, max}$	—	—	13.4	A
FW330G1, 71-56T	$I_{I, max}$	—	—	10.8	A
FW330D1	$I_{I, max}$	—	—	8.9	A
FW330Y1-33T	$I_{I, max}$	—	—	8.3	A
Inrush Transient	i^2t	—	—	2.0	A ² s
Input Reflected-ripple Current, Peak-to-peak (5 Hz to 20 MHz, 12 μ H source impedance; see Figure 17).	—	—	10	—	mAp-p
Input Ripple Rejection (120 Hz)	—	—	60	—	dB

Fusing Considerations

CAUTION: This power module is not internally fused. An input line fuse must always be used.

This encapsulated power module can be used in a wide variety of applications, ranging from simple stand-alone operation to an integrated part of a sophisticated power architecture. To preserve maximum flexibility, internal fusing is not included; however, to achieve maximum safety and system protection, always use an input line fuse. The safety agencies require a normal-blow fuse with a maximum rating of 20 A (see Safety Considerations section). Based on the information provided in this data sheet on inrush energy and maximum dc input current, the same type of fuse with a lower rating can be used. Refer to the fuse manufacturer's data for further information.

Electrical Specifications (continued)

Table 2. Output Specifications

Parameter	Symbol	Min	Typ	Max	Unit
Output Voltage Set Point ($V_i = 48\text{ V}$; $I_o = I_{o, \text{max}}$; $T_c = 25\text{ }^\circ\text{C}$)					
FW330S3R671-56	$V_{o, \text{set}}$	3.58	3.6	3.62	Vdc
FW330F1, -T	$V_{o, \text{set}}$	3.24	3.3	3.35	Vdc
FW330F1-33T	$V_{o, \text{set}}$	3.26	3.3	3.34	Vdc
FW330G71-56T	$V_{o, \text{set}}$	2.48	2.5	2.513	Vdc
FW330D1	$V_{o, \text{set}}$	1.97	2.0	2.03	Vdc
FW330Y1-33T	$V_{o, \text{set}}$	1.78	1.8	1.82	Vdc
Output Voltage (Over all operating input voltage, static resistive load, and temperature conditions until end of life; see Figure 19 and Feature Descriptions.)					
FW330S3R671-56	V_o	3.52	—	3.68	Vdc
FW330F1, -T	V_o	3.20	—	3.40	Vdc
FW330F1-33T	V_o	3.23	—	3.37	Vdc
FW330G71-56T	V_o	2.45	—	2.55	Vdc
FW330D1	V_o	1.94	—	2.06	Vdc
FW330Y1-33T	V_o	1.76	—	1.84	Vdc
Output Regulation:					
Line ($V_i = 36\text{ V to }75\text{ V}$)	—	—	1	2	mV
Load ($I_o = I_{o, \text{min}}$ to $I_{o, \text{max}}$)	—	—	2	4	mV
Temperature ($T_c = -40\text{ }^\circ\text{C to }+100\text{ }^\circ\text{C}$)	—	—	15	50	mV
Output Ripple and Noise Voltage (See Figure 18.):					
RMS; (for non -T, F1 and D1)	—	—	—	40	mVrms
Peak-to-peak (5 Hz to 20 MHz); (for non -T, F1 and D1)	—	—	—	150	mVp-p
RMS	—	—	—	20	mVrms
Peak-to-peak (5 Hz to 20 MHz)	—	—	—	50	mVp-p
External Load Capacitance (total for one unit or multiple paralleled units): Total Output Capacitance [†] :					
FW330S3R671-56	C_o	—	650	*	μF
FW330F1	C_o	0	2,200	*	μF
FW330F1-T, Y1-T	C_o	—	10,000	*	μF
FW330F1-33T	C_o	—	32,000	*	μF
FW330G71-56T	C_o	0	35,000	*	μF
FW330D1	C_o	—	2,200	*	μF
FW330Y1-33T	C_o	—	195,000	*	μF
Output Current (At $I_o < I_{o, \text{min}}$, the modules may exceed output ripple specifications.)					
FW330S3R6	I_o	0.5	—	100	A
	I_o	—	—	90	A

* Consult your sales representative or the factory.

† Exceptionally low values of ESR can lead to diminished stability margins.

Electrical Specifications (continued)

Table 2. Output Specifications (continued)

Parameter	Symbol	Min	Typ	Max	Unit
Output Current-limit Inception ($V_o = 90\%$ of $V_{o, set}$; see Feature Descriptions.)	$I_{o, cli}$	103	—	130*	% $I_{o, max}$
Output Short-circuit Current ($V_o = 1.0$ V; indefinite duration, no hiccup mode.)	—	—	—	170	% $I_{o, max}$
Efficiency ($V_i = 48$ V; $I_o = I_{o, max}$; $T_c = 25$ °C):					
FW330S3R671-56	η	—	80	—	%
FW330F1, -T, -33T	η	—	79	—	%
FW330G71-56T	η	—	76	—	%
FW330D1	η	—	74	—	%
FW330Y1-33T	η	—	72	—	%
Switching Frequency	All	—	500	—	kHz
Dynamic Response (dependent upon capacitive load (ex. FW330G71-56T with 38,000 μ F, 0.6 m Ω , $\dot{I}_o/\dot{I}_T = 10$ A/ μ s, $V_i = 48$ V, $T_c = 25$ °C)):					
Load Change from $I_o = 50\%$ to 75% of $I_{o, max}$:					
Peak Deviation	—	—	20	—	mV
Settling Time ($V_o < 10\%$ of peak deviation)	—	—	300	—	μ s
Load Change from $I_o = 50\%$ to 25% of $I_{o, max}$:					
Peak Deviation	—	—	20	—	mV
Settling Time ($V_o < 10\%$ of peak deviation)	—	—	300	—	μ s

* These are manufacturing test limits. In some situations, results may differ.

Table 3. Isolation Specifications

Parameter	Min	Typ	Max	Unit
Isolation Capacitance	—	1700	—	pF
Isolation Resistance	10	—	—	M Ω

General Specifications

Parameter	Min	Typ	Max	Unit
Calculated MTBF ($I_o = 80\%$ of $I_{o, max}$; $T_c = 40$ °C)		1,700,000		hours
Weight	—	—	340 (12.2)	g (oz.)

Feature Specifications

Unless otherwise indicated, specifications apply over all operating input voltage, resistive load, and temperature conditions. See Feature Descriptions for further information.

Table 4. Feature Specifications

Parameter	Symbol	Min	Typ	Max	Unit
Remote On/Off Signal Interface ($V_I = 0\text{ V}$ to 75 V ; open collector or equivalent compatible; signal referenced to $V_I(-)$ terminal; see Figure 20 and Feature Descriptions.): FW330F1 Preferred Logic: Both Primary and Secondary Referenced Remote On/Off: Logic Low—Module On Logic High—Module Off FW330F Optional Logic (optional for primary referenced remote on/off only): Primary Referenced Remote On/Off: Logic Low—Module Off Logic High—Module On Secondary Referenced Remote On/Off: Logic Low—Module On Logic High—Module Off Logic Low: Ion/off = 1.0 mA Von/off = 0.0 V Logic High (open collector): Ion/off = 0.0 μA Leakage Current Turn-on Time ($I_O = 80\%$ of $I_{O, \text{max}}$; V_O within $\pm 1\%$ of steady state)					
	$V_{\text{on/off}}$	0	—	1.2	V
	$I_{\text{on/off}}$	—	—	1.0	mA
	$V_{\text{on/off}}$	—	—	15	V
	$I_{\text{on/off}}$	—	—	50	μA
	—	—	30	50	ms
Output Voltage Adjustment (See Feature Descriptions.): Output Voltage Remote-sense Range Output Voltage Set-point Adjustment Range (trim) Note: Ensure that the Combination of Remote Sense and Trim Do Not Exceed a Total of 0.5 V.	—	—	—	0.5	V
	—	60	—	110	% $V_{O, \text{nom}}$
Output Overvoltage Protection: FW330S3R671-56 FW330F1, -T FW330F1-33T FW330G71-56T FW330D1 FW330Y1-33T	—	4.1	—	4.7	V
	—	3.52	—	3.91	V
	—	3.72	—	3.91	V
	—	3.1	—	3.4	V
	—	2.4	—	2.8	V
	—	2.52	—	2.65	V
Output Current Monitor ($I_O > 10\text{ A}$, $T_C = 70\text{ }^\circ\text{C}$)	$I_{O, \text{mon}}$	—	$0.5 + 0.038 I_O$	—	V
Synchronization: Clock Amplitude Clock Pulse Width Fan-out Capture Frequency Range	—	4.00	—	5.00	V
	—	0.4	—	—	μs
	—	—	—	1	—
	—	425	—	575	kHz
Forced Load Share Accuracy	—	—	10	—	% $I_{O, \text{rated}}$

Feature Specifications (continued)

Table 4. Feature Specifications (continued)

Parameter	Symbol	Min	Typ	Max	Unit
Power Good Signal (Open collector output: low level indicates power good.):					
Output Sink Current ($V_o \approx 1.5$ V)	—	—	—	50	mA
Maximum Voltage	—	—	—	36	V
High-state Internal Impedance to Ground	—	—	100	—	k Ω
Overtemperature Protection (See Figure 29.)	T _c	—	105	—	°C
Thermal Warning Signal (Open collector output; low level indicates overtemperature shutdown is imminent.):					
Output Sink Current ($V_o \approx 1.5$ V)	—	—	—	6	mA
Maximum Voltage	—	—	—	36	V
High-state Internal Impedance to Ground	—	—	200	—	k Ω
Temperature Monitor (optional instead of thermal warning)	—	—	500 mV +10 mV/°C	—	—
Overvoltage Set Point Adjustment Range (shutdown)	—	50	—	110	%V _O , shutdown, nom
Overcurrent Threshold Adjustment Range	—	10	—	100	%I _O , cli, nom

Solder, Cleaning, and Drying Considerations

Post solder cleaning is usually the final circuit-board assembly process prior to electrical testing. The result of inadequate circuit-board cleaning and drying can affect both the reliability of a power module and the testability of the finished circuit-board assembly. For guidance on appropriate soldering, cleaning, and drying procedures, refer to the *Board-Mounted Power Modules Soldering and Cleaning* Application Note (AP97-021EPS).

Characteristic Curves

The following figures provide typical characteristics for the power modules.

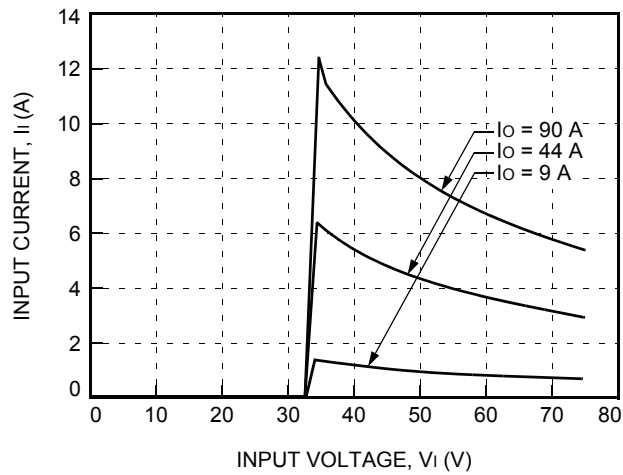

8-3013 (F)

Figure 1. Typical FW330S3R671-56 Input Characteristics at Room Temperature

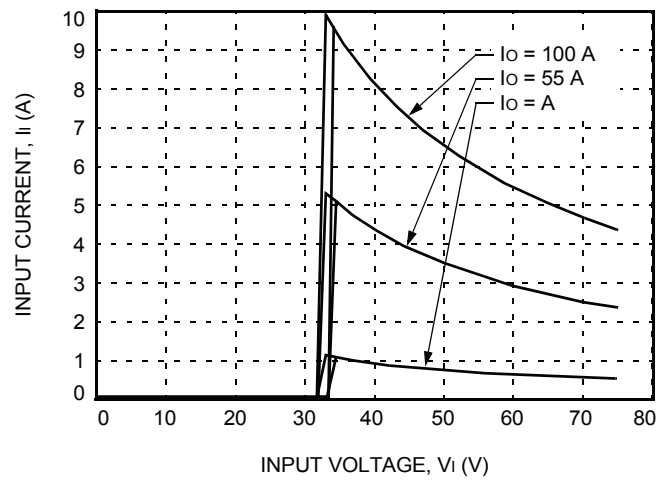

8-3064 (F)

Figure 3. Typical FW330G71-56T Input Characteristics at Room Temperature

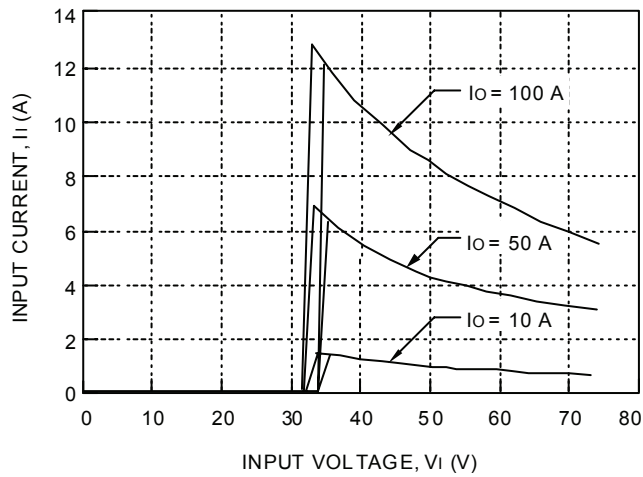

8-2911 (C)

Figure 2. Typical FW330F1 Input Characteristics at Room Temperature

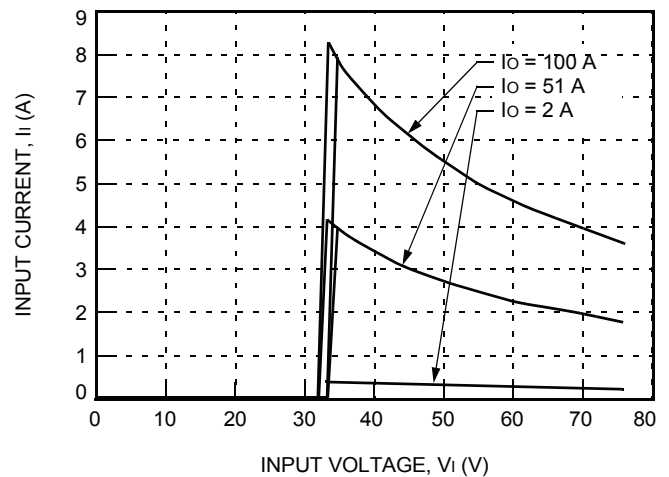

8-2817 (F)

Figure 4. Typical FW330D1 Input Characteristics at Room Temperature

Characteristics Curves (continued)

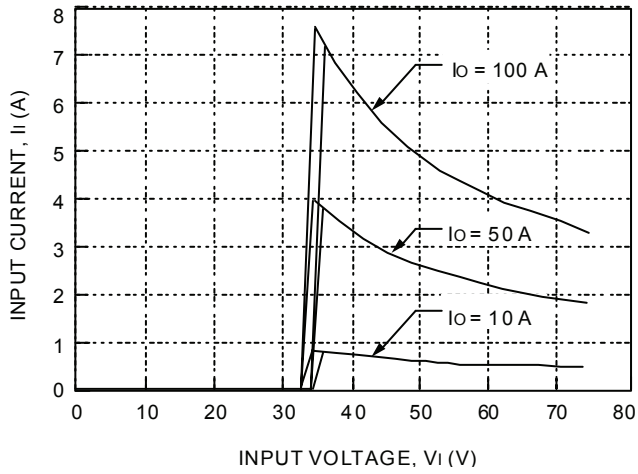

8-2912 (C)

Figure 5. Typical FW330Y1 Input Characteristics at Room Temperature

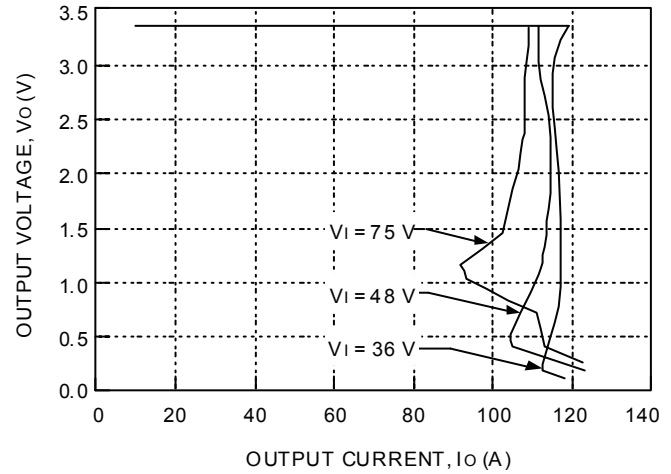

8-2913 (C)

Figure 7. Typical FW330F1 Output Characteristics at Room Temperature

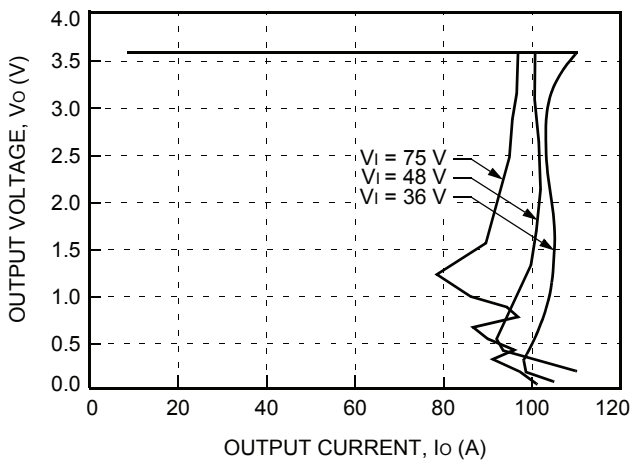

8-3014 (F)

Figure 6. Typical FW330S3R671-56 Output Characteristics at Room Temperature

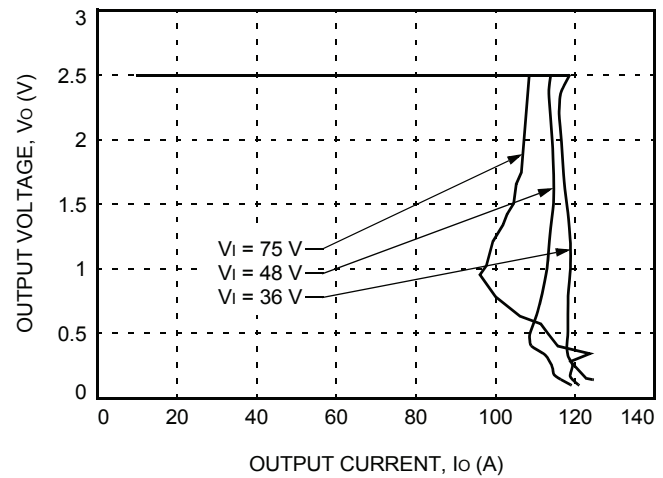

8-3065 (F)

Figure 8. Typical FW330G71-56T Output Characteristics at Room Temperature

Characteristics Curves (continued)

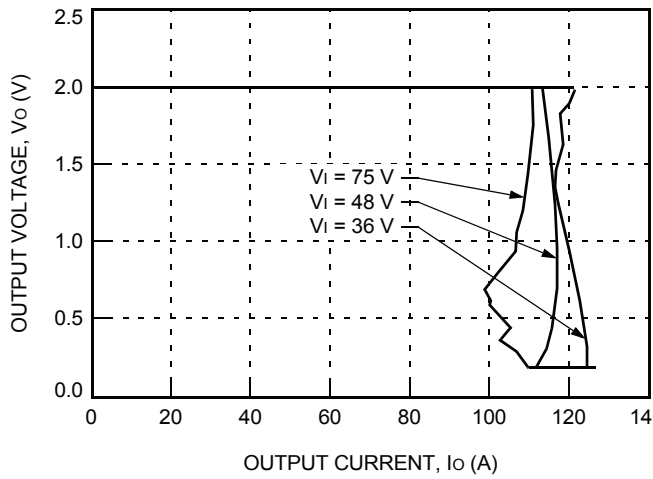

8-2818 (F)

Figure 9. Typical FW330D1 Output Characteristics at Room Temperature

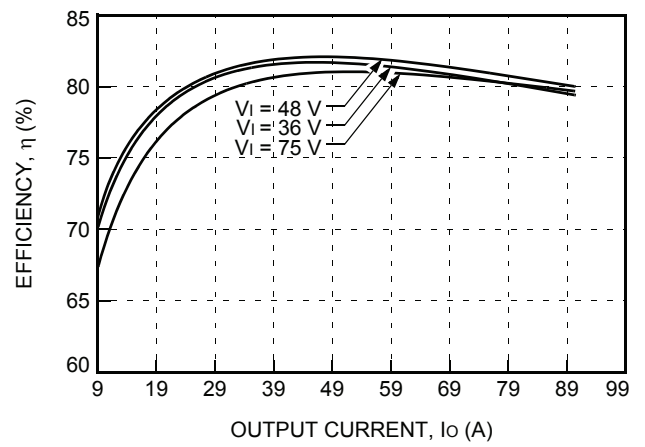

8-3015 (F)

Figure 11. Typical FW330S3R671-56 Converter Efficiency vs. Output Current at Room Temperature

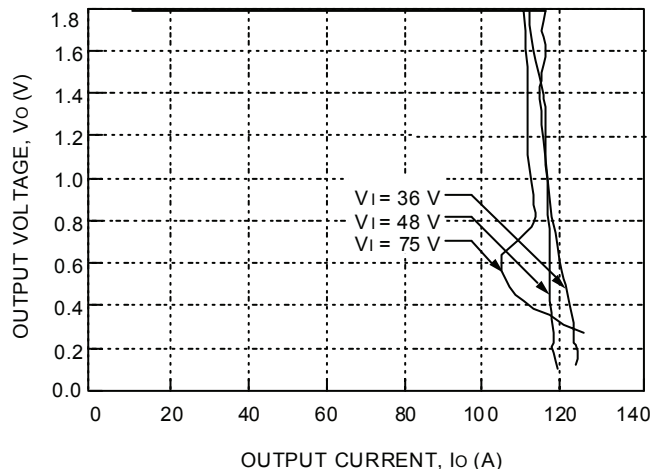

8-2914 (C)

Figure 10. Typical FW330Y1 Output Characteristics at Room Temperature

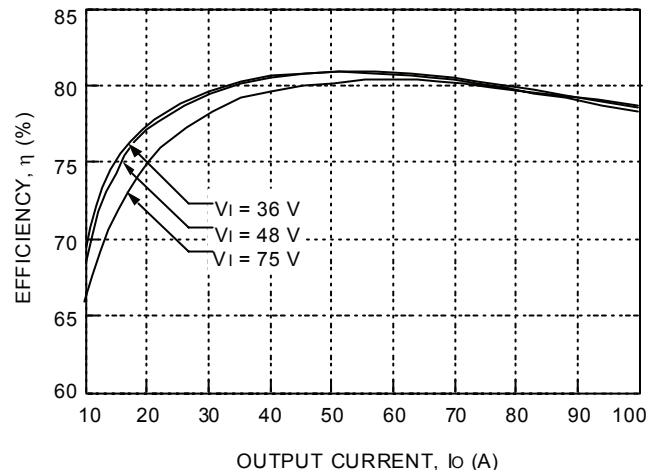

8-2915 (C)

Figure 12. Typical FW330F1 Converter Efficiency vs. Output Current at Room Temperature

Characteristics Curves (continued)

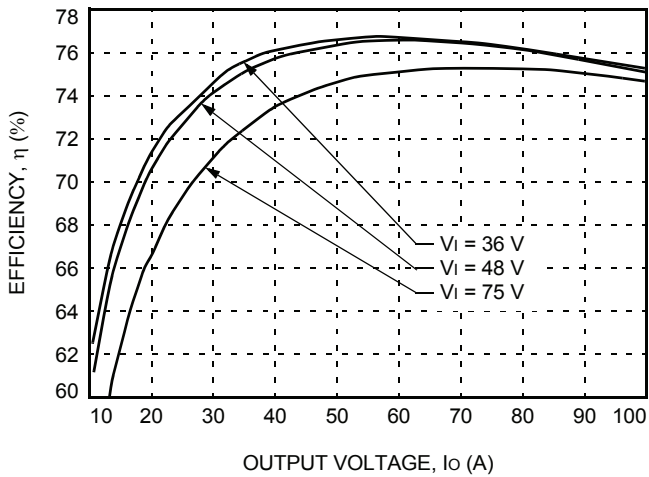

8-3066 (F)

Figure 13. Typical FW330G71-56T Converter Efficiency vs. Output Current at Room Temperature

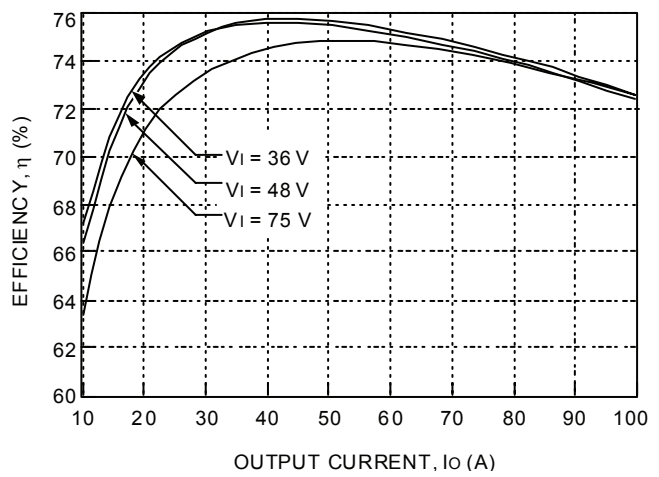

8-2916 (C)

Figure 15. Typical FW330Y1 Converter Efficiency vs. Output Current at Room Temperature

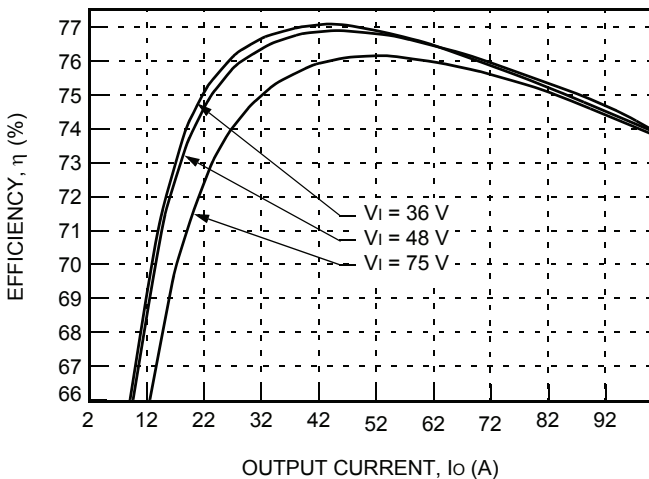

8-2819 (F)

Figure 14. Typical FW330D1 Converter Efficiency vs. Output Current at Room Temperature

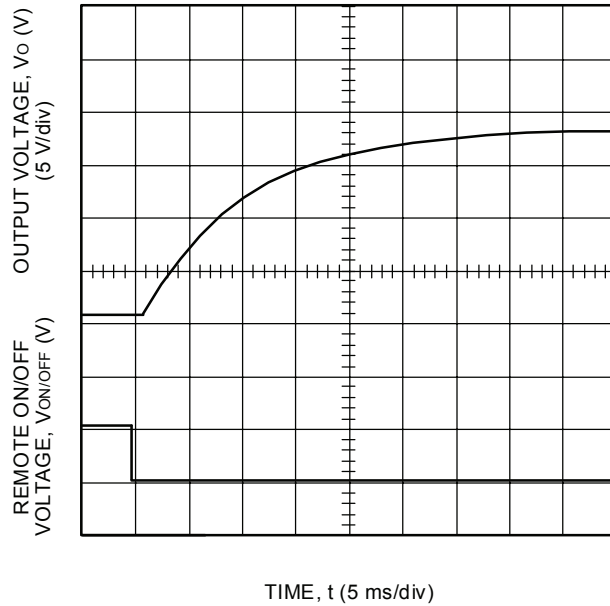

8-2917 (C)

Note: Tested with a 45,000 μ F aluminum and a 1.0 μ F ceramic capacitor across the load.

Figure 16. Typical Start-Up from Remote On/Off FW330Y1; I_o = Full Load

Test Configurations

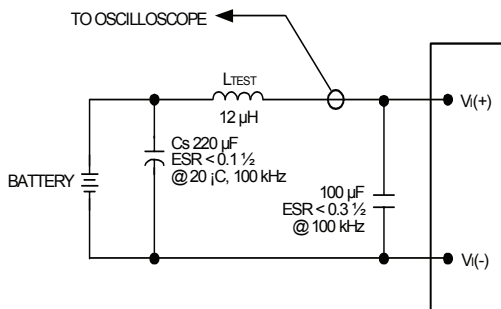

8-203 (C).o

Note: Measure input reflected-ripple current with a simulated source inductance (L_{TEST}) of 12 μH . Capacitor C_s offsets possible battery impedance. Measure current as shown above.

Figure 17. Input Reflected-Ripple Test Setup

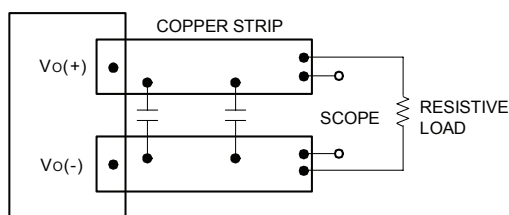

8-513 (C).q

Note: Use a load capacitance as indicated in the Output Specifications table. Scope measurement should be made using a BNC socket. Position the load between 50 mm and 76 mm (2 in. and 3 in.) from the module.

Figure 18. Peak-to-Peak Output Noise Measurement Test Setup

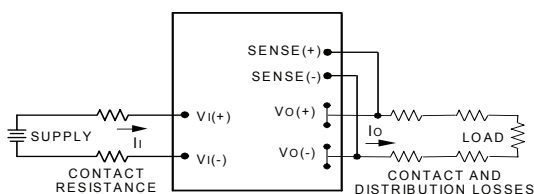

8-683 (C).f

Note: All measurements are taken at the module terminals. When socketing, place Kelvin connections at module terminals to avoid measurement errors due to socket contact resistance.

$$\eta = \left(\frac{[V_o(+)-V_o(-)]I_o}{[V_i(+)-V_i(-)]I_i} \right) \times 100 \quad \%$$

Figure 19. Output Voltage and Efficiency Measurement Test Setup

Lineage Power

Design Considerations

Input Source Impedance

The power module should be connected to a low ac-impedance input source. Highly inductive source impedances can affect the stability of the power module. For the test configuration in Figure 17, a 100 μF electrolytic capacitor (ESR < 0.3 $\frac{3}{4}$ at 100 kHz) mounted close to the power module helps ensure stability of the unit. For other highly inductive source impedances, consult the factory for further application guidelines.

Safety Considerations

For safety-agency approval of the system in which the power module is used, the power module must be installed in compliance with the spacing and separation requirements of the end-use safety agency standard, i.e., *UL1950*, *CSA C22.2 No. 950-95*, and *VDE 0805 (EN60950, IEC950)*.

If the input source is non-SELV (ELV or a hazardous voltage greater than 60 Vdc and less than or equal to 75 Vdc), for the module's output to be considered meeting the requirements of safety extra-low voltage (SELV), all of the following must be true:

- n The input source is to be provided with reinforced insulation from any hazardous voltages, including the ac mains.
- n One V_i pin and one V_o pin are to be grounded, or both the input and output pins are to be kept floating.
- n The input pins of the module are not operator accessible.
- n Another SELV reliability test is conducted on the whole system, as required by the safety agencies, on the combination of supply source and the subject module to verify that under a single fault, hazardous voltages do not appear at the module's output.

Note: Do not ground either of the input pins of the module without grounding one of the output pins. This may allow a non-SELV voltage to appear between the output pin and ground.

The power module has extra-low voltage (ELV) outputs when all inputs are ELV.

The input to these units is to be provided with a maximum 20 A normal-blow fuse in the ungrounded lead.

Feature Descriptions

Overcurrent Protection

To provide protection in a fault (output overload) condition, the unit is equipped with internal current-limiting circuitry and optional delayed shutdown. At the point of current-limit inception, the unit shifts from voltage control to current control. If the output voltage is pulled very low during a severe fault, the current-limit circuit can exhibit either foldback or tailout characteristics (output current decrease or increase). The unit will operate normally once the output current is brought back into its specified range. If the module has the optional delayed current-limit shutdown, the unit will operate normally once the output current is brought back into its specified range, provided the overcurrent condition is removed before the module shuts down.

The current-limit set point can be reduced by connecting a resistor between the overcurrent trim (OCTRIM) pin and SENSE(-) pin. The resistor value is derived by the following equation:

$$R_{cl-adj} = \left(\frac{0.385I_{trim} + 2.08}{3.92 - 0.035I_{trim}} \right) \text{ k}\Omega$$

Where:

R_{cl-adj} is the value of an external resistor between the OCTRIM pin and SENSE(-) pin.

I_{trim} is the trimmed value of the output current-limit set point.

Remote On/Off

There are two remote on/off signals, a primary referenced signal and a secondary referenced signal. Both signals must be asserted on for the module to deliver output power. If either signal is asserted off, the module will not deliver output power. Both signals have internal pull-up circuits and are designed to interface with an open collector pull-down device. Typically, one on/off signal will be permanently enabled by hardwiring it to its return while the other on/off signal is used exclusively for control.

Primary Remote On/Off

The primary remote on/off signal (ON/OFF) is available with either positive or negative logic. Positive logic turns the module on during a logic high and off during a logic low.

Negative logic remote on/off turns the module off during a logic high and on during a logic low. Negative logic (code suffix 1) is the factory-preferred configuration.

To turn the power module on and off, the user must supply a switch to control the voltage between the primary remote on/off terminal ($V_{on/off, pri}$) and the $V_I(-)$ terminal. The switch can be an open collector or equivalent (see Figure 20). A logic low is $V_{on/off, pri} = 0 \text{ V}$ to 1.2 V. The maximum $I_{on/off, pri}$ during a logic low is 1 mA. The switch should maintain a logic-low voltage while sinking 1 mA.

During a logic high, the maximum $V_{on/off, pri}$ generated by the power module is 15 V. The maximum allowable leakage current of the switch at $V_{on/off, pri} = 15 \text{ V}$ is 50 μA .

If not using the primary remote on/off feature, do one of the following:

- n For negative logic, short the ON/OFF pin to $V_I(-)$.
- n For positive logic, leave the ON/OFF pin open.

Secondary Remote On/Off

The secondary remote on/off signal (S-ON/OFF pin) is only available with negative logic. The negative logic signal turns the module off during a logic high and on during a logic low. To turn the power module on and off, the user must supply a switch to control the voltage between the S-ON/OFF pin and the SENSE(-) pin ($V_{on/off, sec}$). The switch can be an open collector or equivalent (see Figure 20). A logic low is $V_{on/off, sec} = 0 \text{ V}$ to 1.2 V. The maximum $I_{on/off, sec}$ during a logic low is 1 mA. The switch should maintain a logic-low voltage while sinking 1 mA.

During a logic high, the maximum $V_{on/off, sec}$ generated by the power module is 15 V. The maximum allowable leakage current of the switch at $V_{on/off, sec} = 15 \text{ V}$ is 50 μA .

If not using the secondary remote on/off feature, short the S-ON/OFF pin to the SENSE(-) pin.

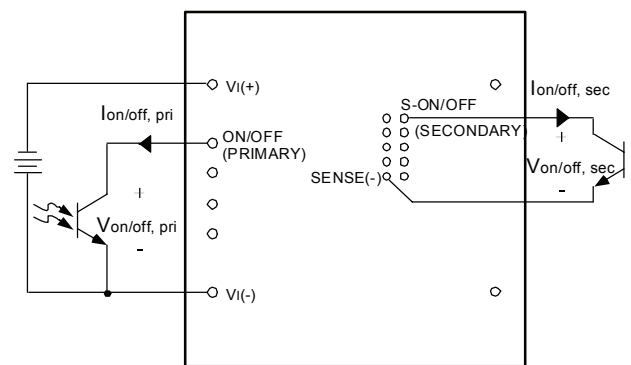

8-1398 (C)

Figure 20. Remote On/Off Implementation

Feature Descriptions (continued)

Remote Sense

Remote sense minimizes the effects of distribution losses by regulating the voltage at the remote-sense connections. The voltage between the remote-sense pins and the output terminals must not exceed the output voltage sense range given in the Feature Specifications table, i.e.:

$$[V_{O(+)} - V_{O(-)}] - [SENSE(+)-SENSE(-)] \leq 0.5 \text{ V}$$

The voltage between the $V_{O(+)}$ and $V_{O(-)}$ terminals must not exceed the minimum value indicated in the output overvoltage shutdown section of the Feature Specifications table. This limit includes any increase in voltage due to remote-sense compensation and output voltage set-point adjustment (trim), see Figure 21.

For remote-sense operation with multiple paralleled units, see the Forced Load Sharing (Parallel Operation) section.

Note: The output voltage of this module may be increased to a maximum of 0.5 V. The 0.5 V is the combination of both the remote sense and the output voltage set-point adjustment (trim).

If not using the remote-sense feature to regulate the output at the point of load, connect SENSE(+) to $V_{O(+)}$ and SENSE(-) to $V_{O(-)}$ at the module.

Although the output voltage can be increased by both the remote sense and by the trim, the maximum increase for the output voltage is not the sum of both. The maximum increase is the larger of either the remote sense or the trim. Consult the factory if you need to increase the output voltage more than the above limitation.

The amount of power delivered by the module is defined as the voltage at the output terminals multiplied by the output current. When using remote sense and trim, the output voltage of the module can be increased, which at the same output current would increase the power output of the module. Care should be taken to ensure that the maximum output power of the module remains at or below the maximum rated power.

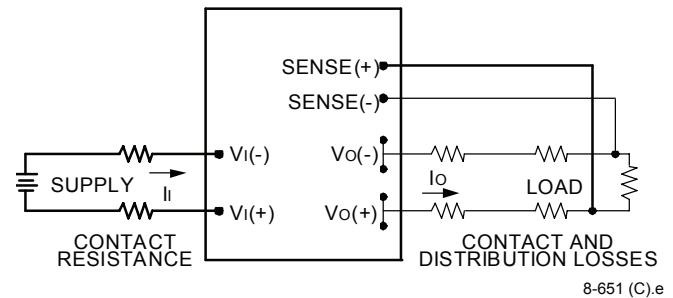

Figure 21. Effective Circuit Configuration for Single-Module Remote-Sense Operation

Output Voltage Set-Point Adjustment (Trim)

Output voltage trim allows the user to increase or decrease the output voltage set point of a module. This is accomplished by connecting an external resistor between the TRIM pin and either the SENSE(+) or SENSE(-) pins. The trim resistor should be positioned close to the module.

If not using the trim feature, leave the TRIM pin open.

With an external resistor between the TRIM and SENSE(-) pins ($R_{adj-down}$), the output voltage set point ($V_{O, adj}$) decreases (see Figure 15). The following equation determines the required external-resistor value to obtain a percentage output voltage change of $\hat{y}\%$.

$$R_{adj-down} = \left(\frac{205}{\Delta\%} - 2.255 \right) \text{ k}\Omega$$

The test results for this configuration are displayed in Figure 23. This figure applies to all output voltages.

With an external resistor connected between the TRIM and SENSE(+) pins (R_{adj-up}), the output voltage set point ($V_{O, adj}$) increases (see Figure 24).

The following equation determines the required external-resistor value to obtain a percentage output voltage change of $\hat{y}\%$.

$$R_{adj-up} = \left(\frac{(V_{O, nom}(1 + \frac{\Delta\%}{100}) - 1.225)}{(1.225\Delta\%)} - 205 - 2.255 \right) \text{ k}\Omega$$

The test results for this configuration are displayed in Figure 25.

Note: The output voltage of this module may be increased to a maximum of 0.5 V. The 0.5 V is the combination of both the remote sense and the output voltage set-point adjustment (trim).

Feature Descriptions (continued)

Output Voltage Set-Point Adjustment (Trim) (continued)

The voltage between the $V_o(+)$ and $V_o(-)$ terminals must not exceed the minimum value of the output over-voltage protection as indicated in the Feature Specifications table. This limit includes any increase in voltage due to remote-sense compensation and output voltage set-point adjustment (trim). See Figure 21.

Although the output voltage can be increased by both the remote sense and by the trim, the maximum increase for the output voltage is not the sum of both. The maximum increase is the larger of either the remote sense or the trim. Consult the factory if you need to increase the output voltage more than the above limitation.

The amount of power delivered by the module is defined as the voltage at the output terminals multiplied by the output current. When using remote sense and trim, the output voltage of the module can be increased, which at the same output current would increase the power output of the module. Care should be taken to ensure that the maximum output power of the module remains at or below the maximum rated power.

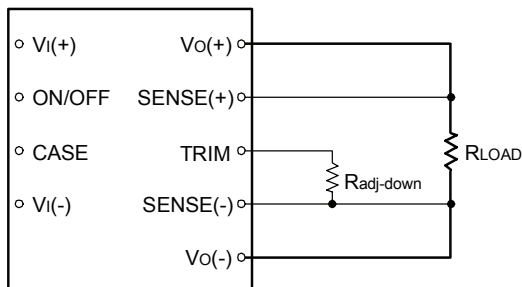

8-748 (C).b

Figure 22. Circuit Configuration to Decrease Output Voltage

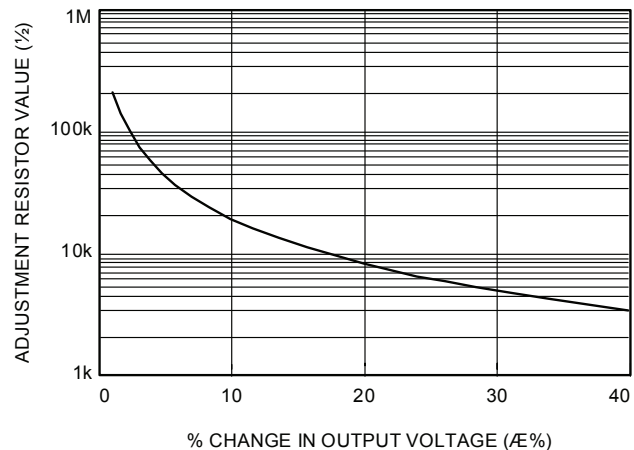

8-2901 (C)

Figure 23. Resistor Selection for Decreased Output Voltage

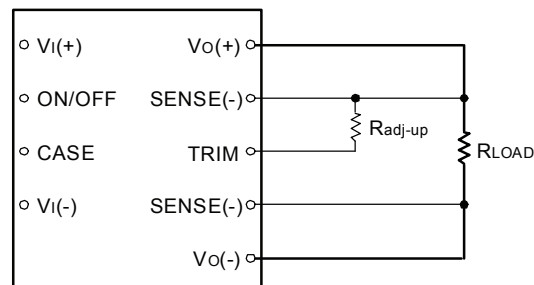

8-715 (C).b

Figure 24. Circuit Configuration to Increase Output Voltage

Feature Descriptions (continued)

Output Voltage Set-Point Adjustment
 (Trim) (continued)

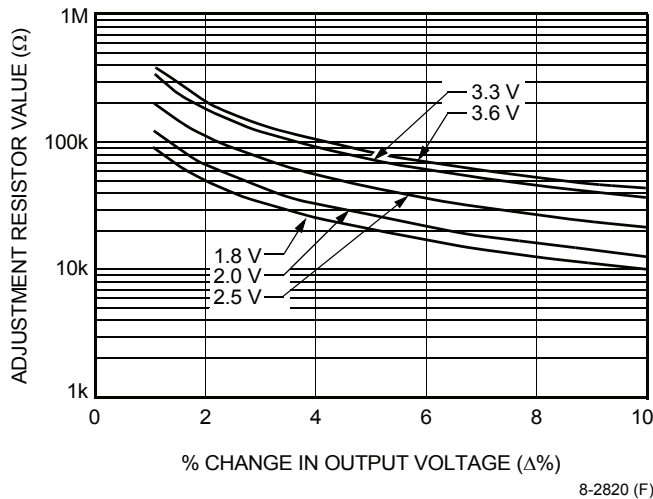

Figure 25. Resistor Selection for Increased Output Voltage

Output Overvoltage Protection

The output overvoltage shutdown consists of control circuitry, independent of the primary regulation loop, that monitors the voltage on the output terminals. The control loop of the over voltage protection has a higher voltage set point than the primary loop (see Feature Specifications table). This provides a redundant voltage control that reduces the risk of output overvoltage and latches the converter off if an overvoltage occurs.

Recovery from latched shutdown is accomplished by cycling the dc input power off for at least 1.0 second or by toggling the primary or secondary referenced remote on/off signal for at least 1.0 second.

The overvoltage shutdown set point can be lowered by placing a resistor between the overvoltage trim (OVTRIM) pin and SENSE(-) pin. This feature is useful if the output voltage of the converter has been trimmed down and a corresponding reduction in overvoltage trip point is desired.

The resistance required from a given overvoltage nominal set point is derived from the following equation:

$$R_{ov-adj} = \left(\frac{4.3 - 2 V_{ov-set}}{V_{ov-set} - 4.3} \right) k\Omega$$

Where:

R_{ov-adj} is the value of an external resistor between the OVTRIM pin and SENSE(-) pin.

V_{ov-set} is the nominal adjusted set point of the overvoltage shutdown threshold.

Output Current Monitor

The CURRENT MON pin provides a dc voltage proportional to the dc output current of the module given in the Feature Specifications table. For example, on the FW330Y1, the V/A ratio is set at 45 mV/A ± 10% @ 70 °C case. At a full load current of 100 A, the voltage on the CURRENT MON pin is 4.5 V. The current monitor signal is referenced to the SENSE(-) pin on the secondary and is supplied from a source impedance of approximately 20 kΩ. It is recommended that the CURRENT MON pin be left open when not in use, although no damage will result if the CURRENT MON pin is shorted to secondary ground. Directly driving the CURRENT MON pin with an external source will detrimentally affect operation of the module and should be avoided.

Module Synchronization

Any module can be synchronized to any other module or to an external clock using the SYNC IN or SYNC OUT pins. The modules are not designed to operate in a master/slave configuration; that is, if one module fails, the other modules will continue to operate.

SYNC IN Pin

This pin can be connected either to an external clock or directly to the SYNC OUT pin of another module.

If an external clock signal is applied to the SYNC IN pin, the signal must be a 500 kHz (±50 kHz) square wave with a 4 Vp-p amplitude. Operation outside this frequency band will detrimentally affect the performance of the module and must be avoided.

If the SYNC IN pin is connected to the SYNC OUT pin of another module, the connection should be as direct as possible, and the $V_I(-)$ pins of the modules must be shorted together.

Unused SYNC IN pins should be tied to $V_I(-)$. If the SYNC IN pin is not used, the module will operate from its own internal clock.

Feature Descriptions (continued)

Module Synchronization

SYNC OUT Pin

This pin contains a clock signal referenced to the $V_I(-)$ pin. The frequency of this signal will equal either the module's internal clock frequency or the frequency established by an external clock applied to the SYNC IN pin.

When synchronizing several modules together, the modules can be connected in a daisy-chain fashion where the SYNC OUT pin of one module is connected to the SYNC IN pin of another module. Each module in the chain will synchronize to the frequency of the first module in the chain.

To avoid loading effects, ensure that the SYNC OUT pin of any one module is connected to the SYNC IN pin of only one module. Any number of modules can be synchronized in this daisy-chain fashion.

Overtemperature Protection

These modules feature an overtemperature protection circuit to safeguard against thermal damage. The circuit shuts down and latches off the module when the maximum case temperature is exceeded. The module can be restarted by cycling the dc input power for at least 1.0 second or by toggling the remote on/off signal for at least 1.0 second.

Forced Load Sharing (Parallel Operation)

For either redundant operation or additional power requirements, the power module can be configured for parallel operation with forced load sharing (see Figure 26). For a typical redundant configuration, fuses or an equivalent should be used to protect against short-circuit conditions. Because of the remote sense, the forward-voltage drops across the fuses do not affect the set point of the voltage applied to the load. For additional power requirements, where multiple units are used to develop combined power in excess of the rated maximum, the fuses are not needed.

An internal anti-rollback circuit prevents either output voltage from falling more than 1 V below the other during light load operation.

Good layout techniques should be observed for noise immunity. To implement forced load sharing, the following connections must be made:

- n The parallel pins of all units must be connected together. The paths of these connections should be as direct as possible.
- n All remote-sense pins must be connected to the power bus at the same point. That is, connect all remote-sense (+) pins to the (+) side of the power bus at the same point, and connect all remote-sense (-) pins to the (-) side of the power bus at the same point. Close proximity and directness are necessary for good noise immunity.
- n Add a 1000 pF capacitor across the PARALLEL pin and SENSE(-) pin of each module. Locate the capacitor as close to the module as possible.

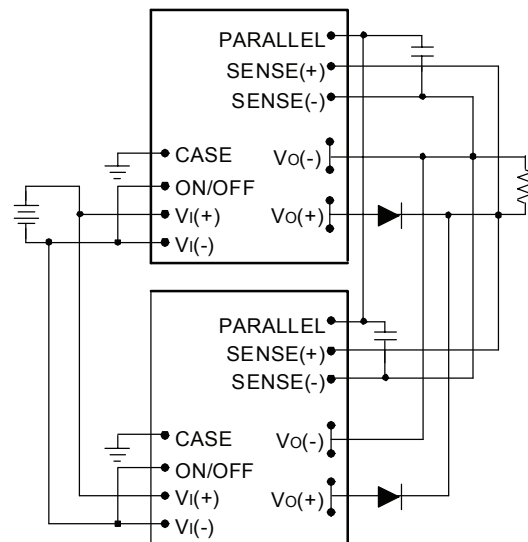

8-581 (C),d

Figure 26. Wiring Configuration for Redundant Parallel Operation

Power Good Signal

The power good signal (PWRGOOD pin) is an open-collector, secondary-referenced pin that is pulled low when all five of the following conditions are met:

1. The overvoltage shutdown latch is not set.
2. The thermal shutdown latch is not set.
3. The unit is not in current limit.
4. Secondary internal bias is present.
5. The sensed output voltage is greater than the output undervoltage set-point.

Feature Descriptions (continued)

Power Good Signal (continued)

The output undervoltage set-point is adjustable by using the output undervoltage set-point adjustment pin (OUSP_{adj}). This is accomplished by connecting an external resistor between the OUSP_{adj} pin and the SENSE(-) pin (see Figure 27). The following equation determines the required external-resistor value to obtain a percentage output voltage set-point of $\hat{y}\%$.

For 1.8 V:

$$R_{adj} = \left(\frac{1218 - \Delta\%}{\Delta\% - 68} \right) \text{ k}\Omega$$

For 2.0 V:

$$R_{adj} = \left(\frac{1096 - \Delta\%}{\Delta\% - 61.25} \right) \text{ k}\Omega$$

For 2.5 V:

$$R_{adj} = \left(\frac{701 - \Delta\%}{\Delta\% - 49} \right) \text{ k}\Omega$$

For 3.3 V:

$$R_{adj} = \left(\frac{256 - \Delta\%}{\Delta\% - 54} \right) \text{ k}\Omega$$

For 3.6 V:

$$R_{adj} = \left(\frac{241 - \Delta\%}{\Delta\% - 50} \right) \text{ k}\Omega$$

The test results for this configuration are displayed in Figure 28. This figure applies to all output voltages.

If not using the output undervoltage set-point adjust feature, leave the OUSP_{adj} pin open. When the OUSP_{adj} pin is left open, the set-point of the output undervoltage is about half of the nominal output voltage.

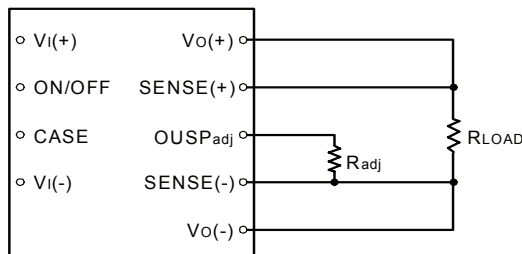

8-2898 (C)

Figure 27. Circuit Configuration to Adjust the Output Undervoltage Set-Point

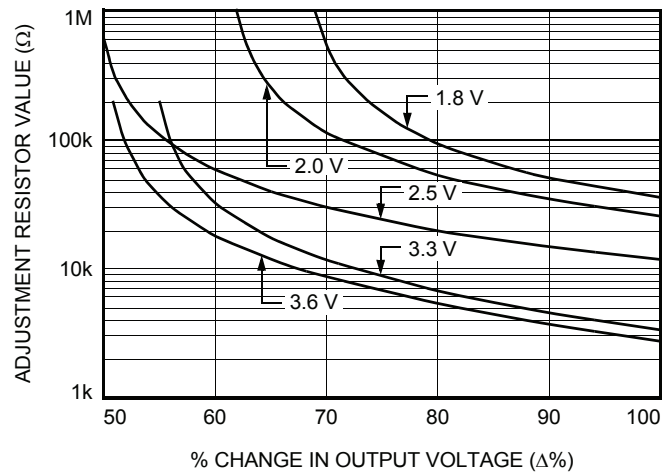

8-3067 (F)

Figure 28. Resistor Selection for Output Undervoltage Set-Point Adjustment

There is one situation where the power good signal can be low even though the module has failed. This can occur when the module is paralleled with other modules for additional output power (i.e., the output ORing diodes would not be used). If one module power train stops delivering power (fails), the other paralleled module(s) would provide a voltage at the output pin of the failed module. The failed module would then not detect that its output power was not being delivered. However, in this situation, the current monitor pins of the paralleled modules would indicate that current is not being delivered from one module and that module had failed.

For redundant applications, the ORing diodes would keep the other module voltages from being applied to the failed module output and the power good signal would indicate a failure.

Feature Descriptions (continued)

Thermal Warning Signal

The thermal warning (THERM) pin is a secondary-referenced, open-collector output that shorts to SENSE(-) a few degrees before the module goes into thermal shutdown.

When the module temperature cools, the thermal warning pin will open, but the unit will remain latched off until the input power or the primary or secondary referenced remote on/off is recycled for 1.0 second.

Temperature Monitor

As an option a temperature monitor signal can be provided instead of the thermal warning signal (using the same pin). The temperature monitor signal provides a dc voltage proportional to the temperature of the module as indicated in the Feature Specifications table. For example, on the FW330F1-T at 100 °C, the voltage on the THERM pin would be 1.5 V. The temperature monitor signal is referenced to the SENSE(-) pin on the secondary and is supplied from a source impedance of approximately 200 k Ω . It is recommended that the THERM pin be left open when not in use, although no damage will result if the THERM pin is shorted to secondary ground.

Module ID

The module ID signal allows the user to electronically identify the module part number. This feature is useful during customer factory assembly, before power is applied, to ensure that the correct module is inserted. A resistor placed between the Mod ID pin and SENSE(-) pin has a resistance that correlates to the module part number, as indicated in the following table:

Module Part Number	Mod ID Resistance
FW330S3R671-56	100 k $\frac{3}{4}$
FW330F1	20.5 k $\frac{3}{4}$
FW330F1-T	10 k $\frac{3}{4}$
FW330F1-33T	5.11 $\frac{3}{4}$
FW330G71-56T	348 k $\frac{3}{4}$
FW330D1	2490 $\frac{3}{4}$
FW330Y1-33T	681 $\frac{3}{4}$

Thermal Considerations

Introduction

The power modules operate in a variety of thermal environments; however, sufficient cooling should be provided to help ensure reliable operation of the unit. Heat-dissipating components inside the unit are thermally coupled to the case. Heat is removed by conduction, convection, and radiation to the surrounding environment. Proper cooling can be verified by measuring the case temperature. Peak temperature occurs at the position indicated in Figure 29.

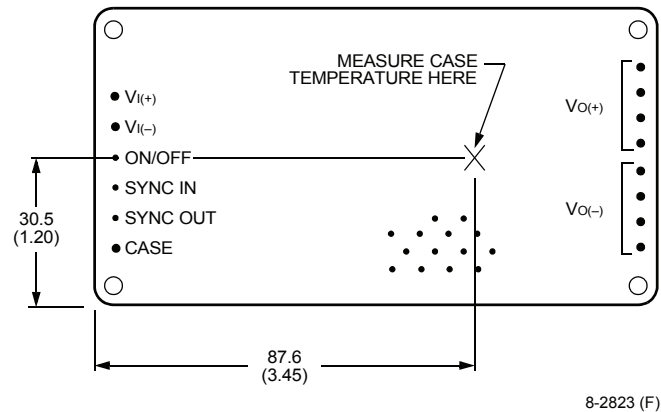

Note: Top view, measurements shown in millimeters and (inches). Pin locations are for reference only.

Figure 29. Case Temperature Measurement Location

The temperature at this location should not exceed 100 °C. The maximum continuous case temperature should be limited to a lower value for higher reliability. The output power of the module should not exceed the rated power for the module as listed in the Ordering Information table.

Heat Transfer Without Heat Sinks

Derating curves for forced-air cooling without a heat sink are shown in Figures 30 and 31. These curves can be used to determine the appropriate airflow for a given set of operating conditions. For example, if the unit with airflow parallel to its longest side (longitudinal orientation) can dissipate 30 W of heat, the correct airflow in a 40 °C environment is 1 m/s (200 ft./min.).

Thermal Considerations (continued)

Heat Transfer Without Heat Sinks (continued)

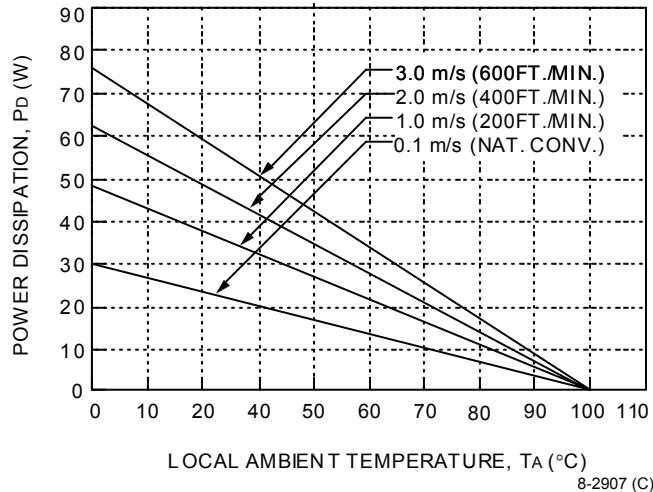

Figure 30. Convection Power Derating with No Heat Sink; Airflow Along Width; Transverse Orientation

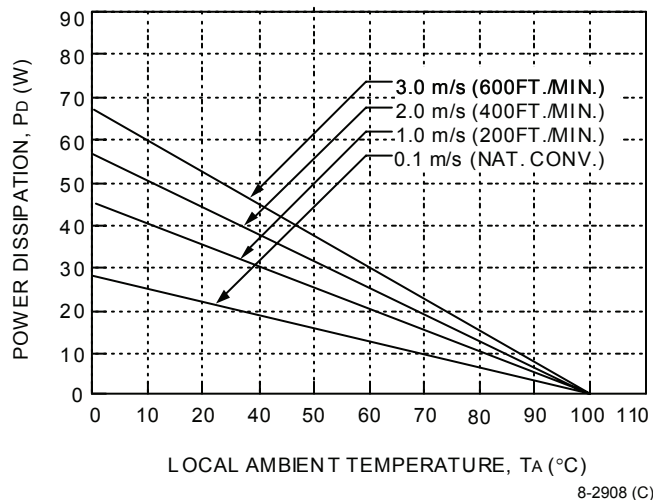

Figure 31. Convection Power Derating with No Heat Sink; Airflow Along Length; Longitudinal Orientation

Heat Transfer with Heat Sinks

The power modules have through-threaded, M3 x 0.5 mounting holes, which enable heat sinks or cold plates to be attached to the module. The mounting torque must not exceed 0.56 N-m (5 in.-lb.). For the screw attachment from the pin side, the recommended hole

Lineage Power

size on the customer's PWB around the mounting holes is 0.130 ± 0.005 inches. If a larger hole is used, the mounting torque from the pin side must not exceed 0.25 N-m (2.2 in.-lb.).

Figures 32 and 33 shows the power derating for a module in natural convection with the heat sinks shown in Figures 42 and 43. Natural convection is the heat transfer produced when air in contact with a hot surface is heated, causing it to rise. An open environment is required with no external forces moving the air. Figures 32 and 33 apply when the module is the only source of heat present in the system, generating airflow of approximately 10 ft./min. to 20 ft./min. Some systems with other heat dissipating components can generate airflows greater than 20 ft./min.

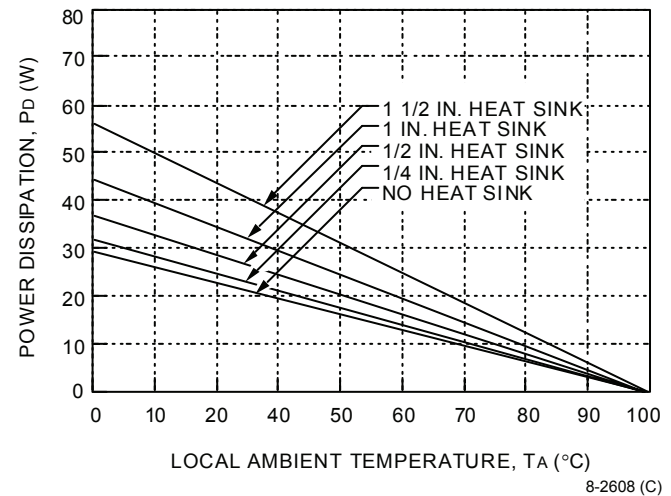

Figure 32. Heat Sink Power Derating Curves Natural Convection, Longitudinal Orientation

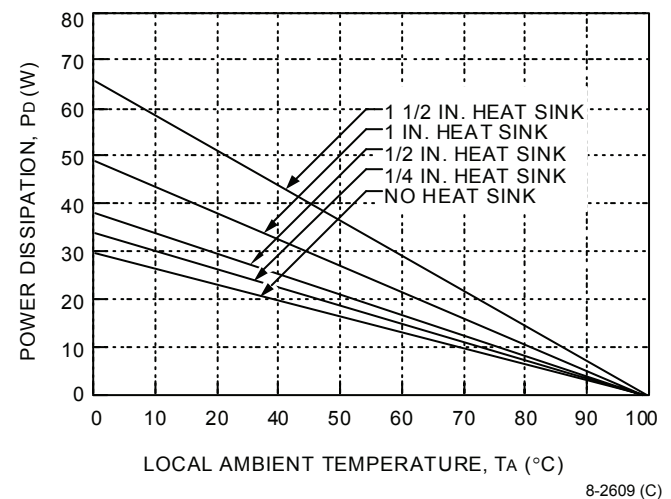

Figure 33. Heat Sink Power Derating Curves Natural Convection, Transverse Orientation

Thermal Considerations (continued)

Heat Transfer with Heat Sinks (continued)

Figures 32 and 33 can be used to predict which heat sink a module will require in a natural convection environment.

For example when a module is transversely oriented in a 20 °C ambient and dissipates 50 W, then a 1.5 in. heat sink is required.

Thermal derating with heat sinks is expressed by using the overall thermal resistance of the module. Total module thermal resistance (θ_{ca}) is defined as the maximum case temperature rise ($\Delta T_{C, max}$) divided by the module power dissipation (P_D):

$$\theta_{ca} = \left[\frac{\Delta T_{C, max}}{P_D} \right] = \left[\frac{(T_C - T_A)}{P_D} \right]$$

The location to measure case temperature (T_C) is shown in Figure 29. Case-to-ambient thermal resistance vs. airflow for various heat sink configurations is shown in Figure 34 and 35. These curves were obtained by experimental testing of heat sinks, which are offered in the product catalog.

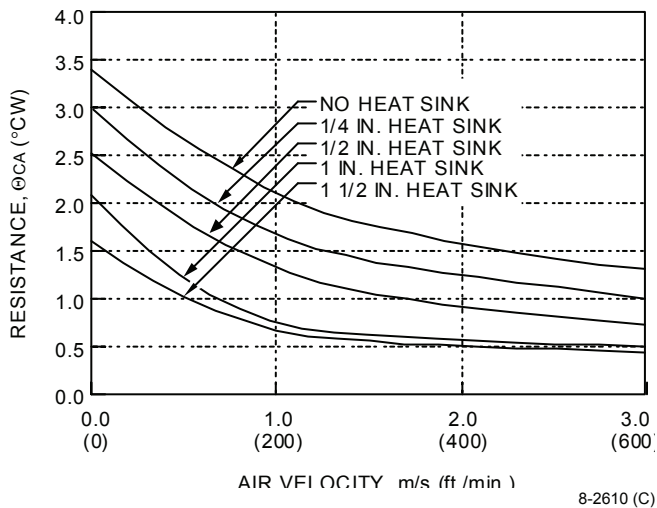

Figure 34. Case-to-Ambient Thermal Resistance Curves; Transverse Orientation

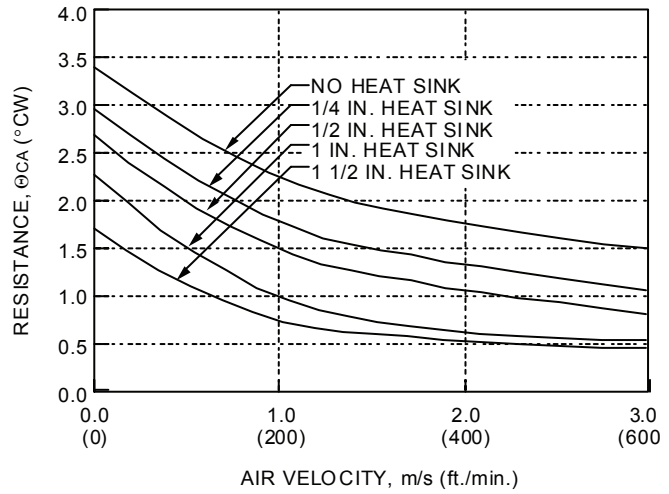

Figure 35. Case-to-Ambient Thermal Resistance Curves; Longitudinal Orientation

These measured resistances are from heat transfer from the sides and bottom of the module as well as the top side with the attached heat sink; therefore, the case-to-ambient thermal resistances shown are generally lower than the resistance of the heat sink by itself. The module used to collect the data in Figures 34 and 35 had a thermal-conductive dry pad between the case and the heat sink to minimize contact resistance.

To choose a heat sink, determine the power dissipated as heat by the unit for the particular application. Figures 37 through 40 show typical heat dissipation for a range of output currents and three voltages for the FW330 modules.

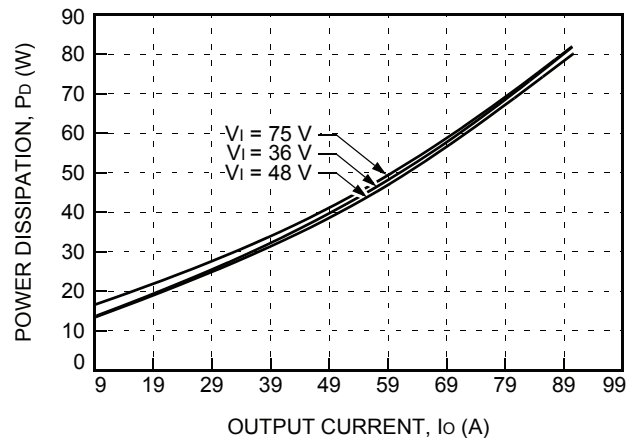
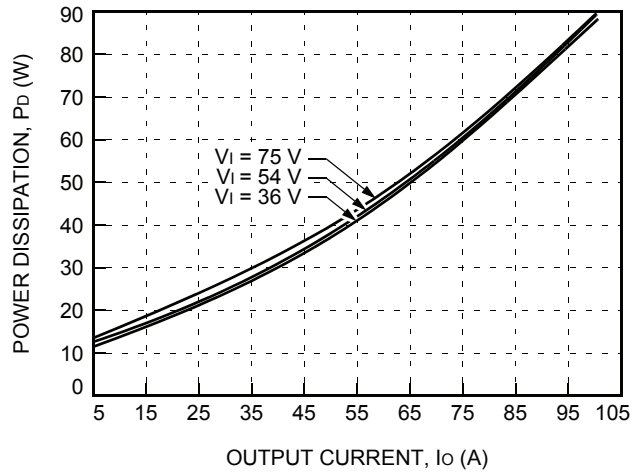

Figure 36. FW330S3R671-56 Power Dissipation vs. Output Current at 25 °C

Thermal Considerations (continued)

Heat Transfer with Heat Sinks (continued)



8-3017 (F)

Figure 37. Fw330F1 Power Dissipation vs. Output Current at 25 °C

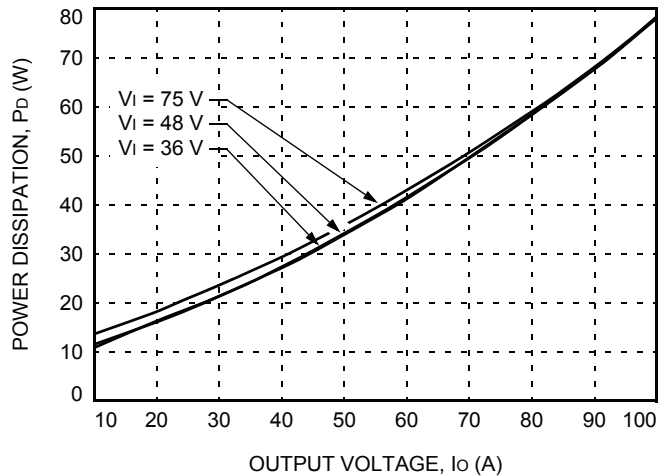

8-3068 (F)

Figure 38. FW330G71-56T Power Dissipation vs. Output Current at 25 °C

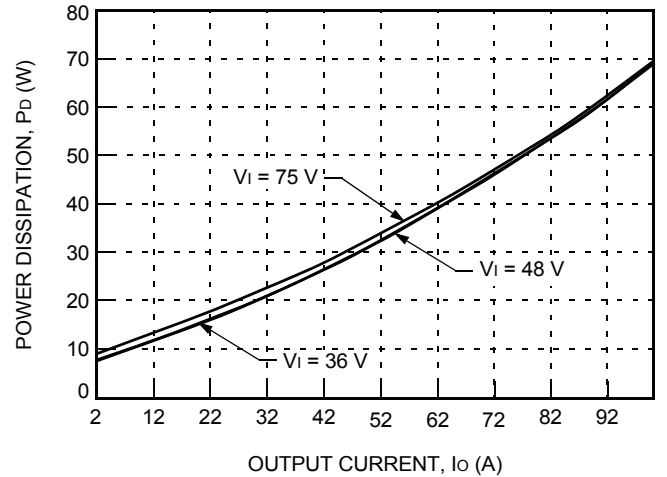

8-2821 (F)

Figure 39. FW330D1 Power Dissipation vs. Output Current at 25 °C

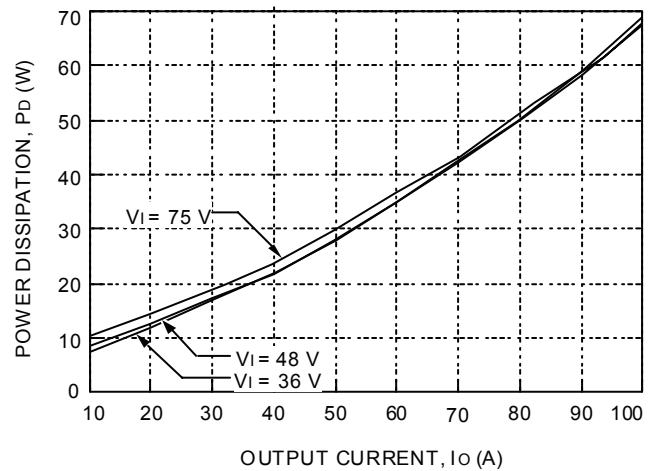

8-2910 (C)

Figure 40. FW330Y1 Power Dissipation vs. Output Current at 25 °C

Thermal Considerations (continued)

Heat Transfer with Heat Sinks (continued)

Example

If an 85 °C case temperature is desired, what is the minimum airflow necessary? Assume the FW330Y1 module is operating at nominal line and an output current of 100 A, maximum ambient air temperature of 40 °C, and the heat sink is 1 inch.

Solution

Given: $V_I = 54 \text{ V}$
 $I_O = 100 \text{ A}$
 $T_A = 40 \text{ °C}$
 $T_C = 85 \text{ °C}$
 Heat sink = 1 inch

Determine P_D by using Figure 37:

$$P_D = 68 \text{ W}$$

Then solve the following equation:

$$\theta_{ca} = \left[\frac{(T_C - T_A)}{P_D} \right]$$

$$\theta_{ca} = \left[\frac{(85 - 40)}{68} \right]$$

$$\theta_{ca} = 0.66 \text{ °C/W}$$

Use Figures 34 and 35 to determine air velocity for the 1 inch heat sink. The minimum airflow necessary for this module depends on heat sink fin orientation and is shown below:

- n 1.25 m/s (250 ft./min.) (transverse orientation)
- n 1.75 m/s (350 ft./min.) (longitudinal orientation)

Custom Heat Sinks

The heat sink resistances of Figures 34 and 35 are dominated by the heat sink geometry of the heat sinks shown in Figures 42 and 43. Because the heat sink geometry is fixed, the heat sinks are not optimized for all the air speeds shown. It may be necessary to design a custom heat sink that provides lower thermal resistance than the ones used in this testing or to use other heat transfer removal methods.

A more detailed model can be used to determine the required thermal resistance of a heat sink to provide necessary cooling. The total module resistance can be separated into a resistance from case-to-sink (θ_{cs}) and sink-to-ambient (θ_{sa}) as shown in Figure 41.

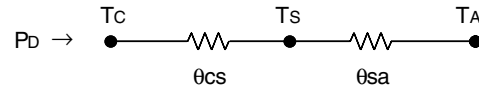

8-1304 (C)

Figure 41. Resistance from Case-to-Sink and Sink-to-Ambient

When custom heat sinks are used, the interface between the module and the heat sink base should be filled with a thermally conductive material (like a thermal grease or a thermal pad/foil) to reduce the thermal resistance between the module and the heat sink. It is recommended that the material is at least 6 mils thick to compensate for flatness differences between the module and the heat sink. Also, special considerations should be paid to the flatness and surface finish of the heat sink base to ensure the lowest thermal interface resistance feasible.

For a managed interface using thermal grease or foils, a value of $\theta_{cs} = 0.1 \text{ °C/W}$ to 0.3 °C/W is typical. The solution for heat sink resistance is:

$$\theta_{sa} = \left[\frac{(T_C - T_A)}{P_D} \right] - \theta_{cs}$$

This equation assumes that all dissipated power must be shed by the heat sink. Depending on the user-defined application environment, a more accurate model, including heat transfer from the sides and bottom of the module, can be used. This equation provides a conservative estimate for such instances.

EMC Considerations

For assistance with designing for EMC compliance, please refer to the FLTR100V10 data sheet (DS99-294EPS).

Layout Considerations

Copper paths must not be routed beneath the power module mounting inserts. For additional layout guidelines, refer to the FLTR100V10 data sheet (DS99-294EPS).

Outline Diagram

Dimensions are in millimeters and (inches).

Tolerances: x.x mm ± 0.5 mm (x.xx in. ± 0.02 in.),
x.xx mm ± 0.25 mm (x.xxx in. ± 0.010 in.)

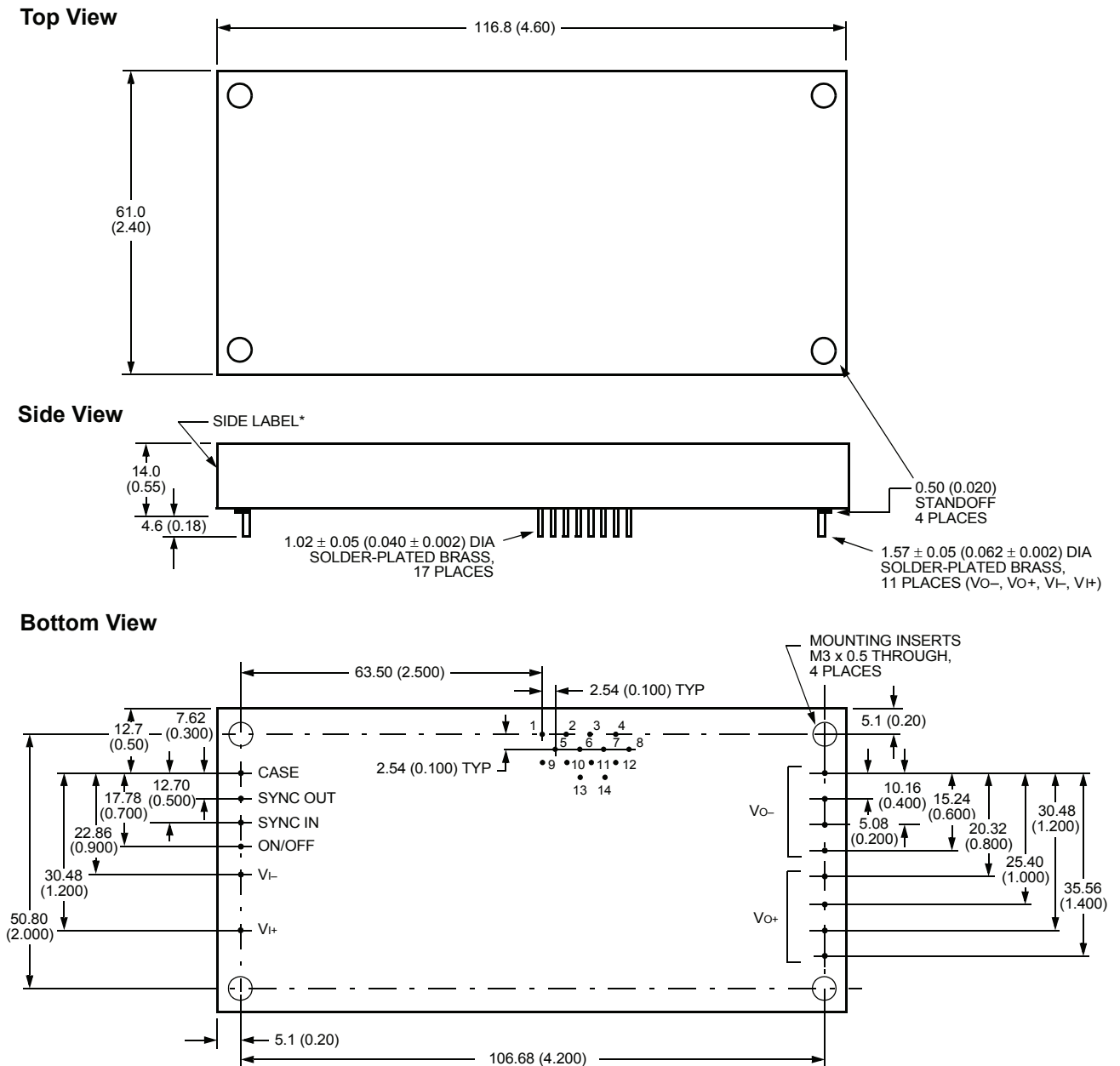

8-2824 (F)

* Side label includes Lineage name, product designation, safety agency markings, input/output voltage and current ratings and bar code.

Recommended Hole Pattern

Component-side footprint.

Dimensions are in millimeters and (inches).

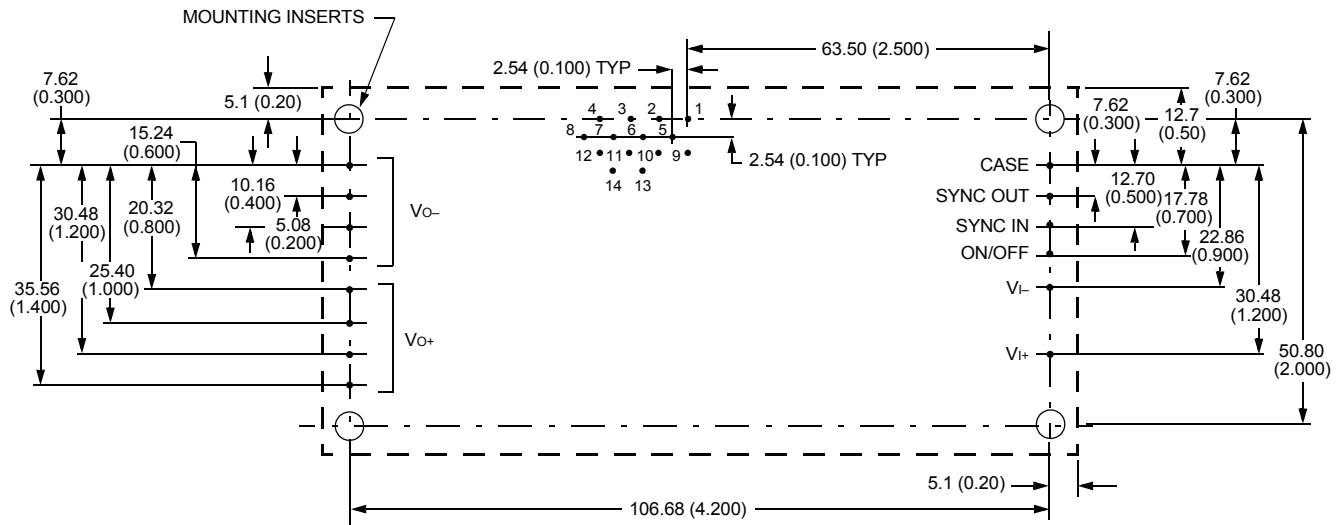

8-2824 (F)

Table 5. Pin Functions

Pin	Function	Pin	Function
1	THERM	8	OVTRIM
2	CURMON	9	OUSPadj
3	VoTRIM	10	MOD_ID
4	SENSE(-)	11	OCTRIM
5	PWRGOOD	12	S-ON/OFF
6	PARALLEL	13	OPEN
7	SENSE(+)	14	OPEN

Ordering Information

Table 6. Device Codes

Input Voltage	Output Voltage	Output Power	Device Code	Comcode
48 V	3.6 V	330 W	FW330S3R671-56	108547316
48 V	3.3 V	330 W	FW330F1	108545948
48 V	3.3 V	330 W	FW330F1-T	108337320
48 V	3.3 V	330 W	FW330F1-33T	108448135
48 V	2.5 V	250 W	FW330G71-56T	108547258
48 V	2.0 V	200 W	FW330D1	108545963
48V	1.8 V	180 W	FW330Y1-33T	108267691

Optional features can be ordered using the suffixes shown in Table 7. The suffixes follow the last letter of the device code and are placed in descending order. For example, the device codes for a FW330F-33T module with the following options are shown below:

Positive logic	FW330F-33T
Negative logic	FW330F1-33T
Negative logic and delayed current-limit shutdown	FW330F31-33T

Table 7. Device Options

Option	Suffix
Delayed current-limit shutdown	3
Negative remote on/off logic	1
Positive remote on/off logic	—
Temperature monitor	7

Ordering Information (continued)

Table 8. Device Accessories

Accessory	Comcode
1/4 in. transverse kit (heat sink, thermal pad, and screws)	847308335
1/4 in. longitudinal kit (heat sink, thermal pad, and screws)	847308327
1/2 in. transverse kit (heat sink, thermal pad, and screws)	847308350
1/2 in. longitudinal kit (heat sink, thermal pad, and screws)	847308343
1 in. transverse kit (heat sink, thermal pad, and screws)	847308376
1 in. longitudinal kit (heat sink, thermal pad, and screws)	847308368
1 1/2 in. transverse kit (heat sink, thermal pad, and screws)	847308392
1 1/2 in. longitudinal kit (heat sink, thermal pad, and screws)	847308384

Dimension are in millimeters and (inches).

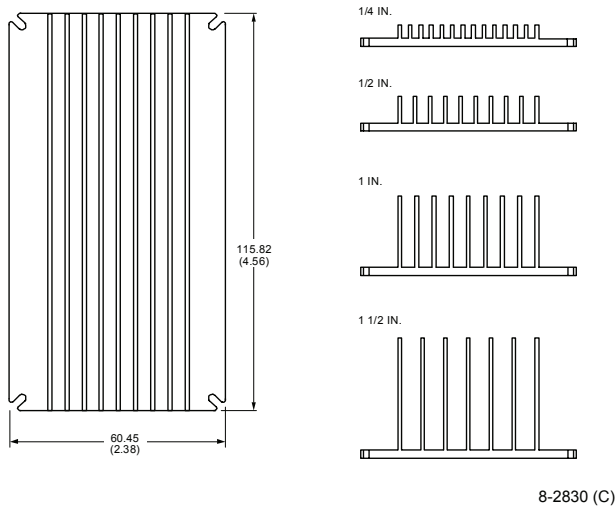

Figure 42. Longitudinal Heat Sink

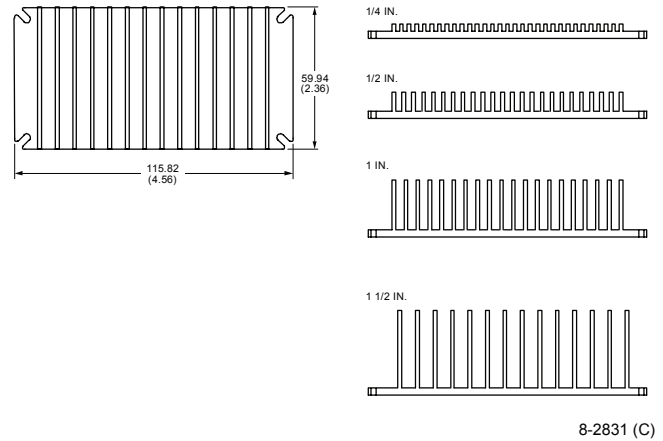

Figure 43. Transverse Heat Sink

Notes



World Wide Headquarters

Lineage Power Corporation

3000 Skyline Drive, Mesquite, TX 75149, USA

+1-800-526-7819

(Outside U.S.A.: **+1-972-284-2626**)

www.lineagepower.com

e-mail: techsupport1@lineagepower.com

Asia-Pacific Headquarters

Tel: +65 6416 4283

Europe, Middle-East and Africa Headquarters

Tel: +49 89 6089 286

India Headquarters

Tel: +91 80 28411633

Lineage Power reserves the right to make changes to the product(s) or information contained herein without notice. No liability is assumed as a result of their use or application. No rights under any patent accompany the sale of any such product(s) or information.

© 2008 Lineage Power Corporation, (Mesquite, Texas) All International Rights Reserved.

April 3, 2008

Document No: DS04-002 ver.1.1

PDF name: fw330 single.pdf