

DATA SHEET

For a complete data sheet, please also download:

- The IC04 LOCMOS HE4000B Logic Family Specifications HEF, HEC
- The IC04 LOCMOS HE4000B Logic Package Outlines/Information HEF, HEC

HEF4076B

MSI

Quadruple D-type register with
3-state outputs

Product specification
File under Integrated Circuits, IC04

January 1995

Quadruple D-type register with 3-state outputs

HEF4076B
MSI

DESCRIPTION

The HEF4076B is a quadruple edge-triggered D-type flip-flop with four data inputs (D_0 to D_3), two active LOW data enable inputs (\overline{ED}_0 and \overline{ED}_1), a common clock input (CP), four 3-state outputs (O_0 to O_3), two active LOW output enable inputs (\overline{EO}_0 and \overline{EO}_1), and an overriding asynchronous master reset input (MR).

Information on D_0 to D_3 is stored in the four flip-flops on the LOW to HIGH transition of CP if both \overline{ED}_0 and \overline{ED}_1 are LOW. A HIGH on either \overline{ED}_0 or \overline{ED}_1 prevents the flip-flops from changing on the LOW to HIGH transition of CP, independent of the information on D_0 to D_3 . When both \overline{EO}_0 and \overline{EO}_1 are LOW, the contents of the four flip-flops are available at O_0 to O_3 . A HIGH on either \overline{EO}_0 or \overline{EO}_1 forces O_0 to O_3 into the high impedance OFF-state. A HIGH on MR resets all four flip-flops, independent of all other input conditions.

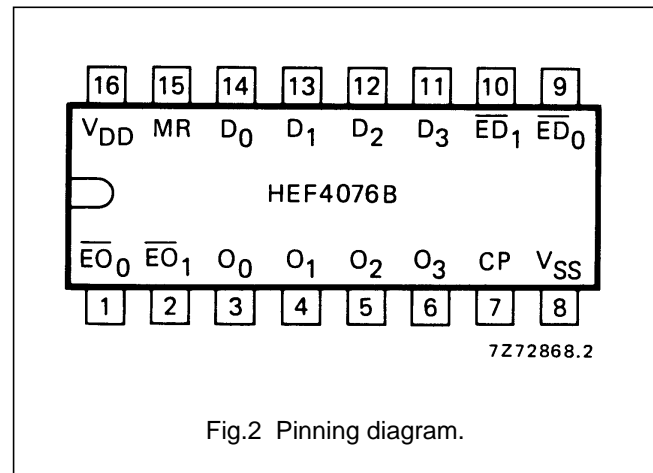
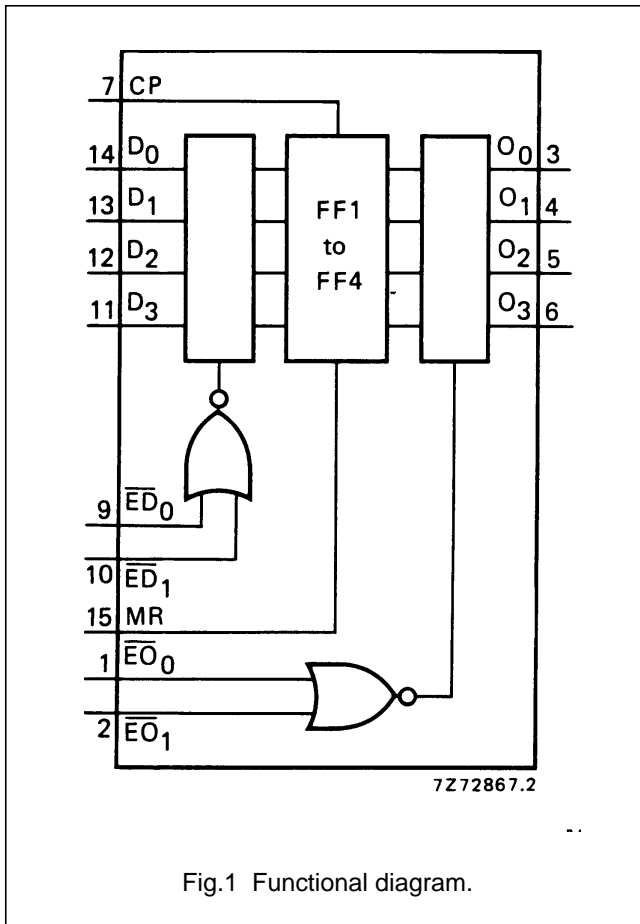

PINNING

- D_0 to D_3 data inputs
- $\overline{ED}_0, \overline{ED}_1$ data enable inputs (active LOW)
- $\overline{EO}_0, \overline{EO}_1$ output enable inputs (active LOW)
- CP clock input (LOW to HIGH, edge-triggered)
- MR master reset input
- O_0 to O_3 data outputs

FAMILY DATA, I_{DD} LIMITS category MSI

See Family Specifications

- HEF4076BP(N): 16-lead DIL; plastic (SOT38-1)
- HEF4076BD(F): 16-lead DIL; ceramic (cerdip) (SOT74)
- HEF4076BT(D): 16-lead SO; plastic (SOT109-1)
- (): Package Designator North America

Quadruple D-type register with 3-state outputs

HEF4076B
MSI

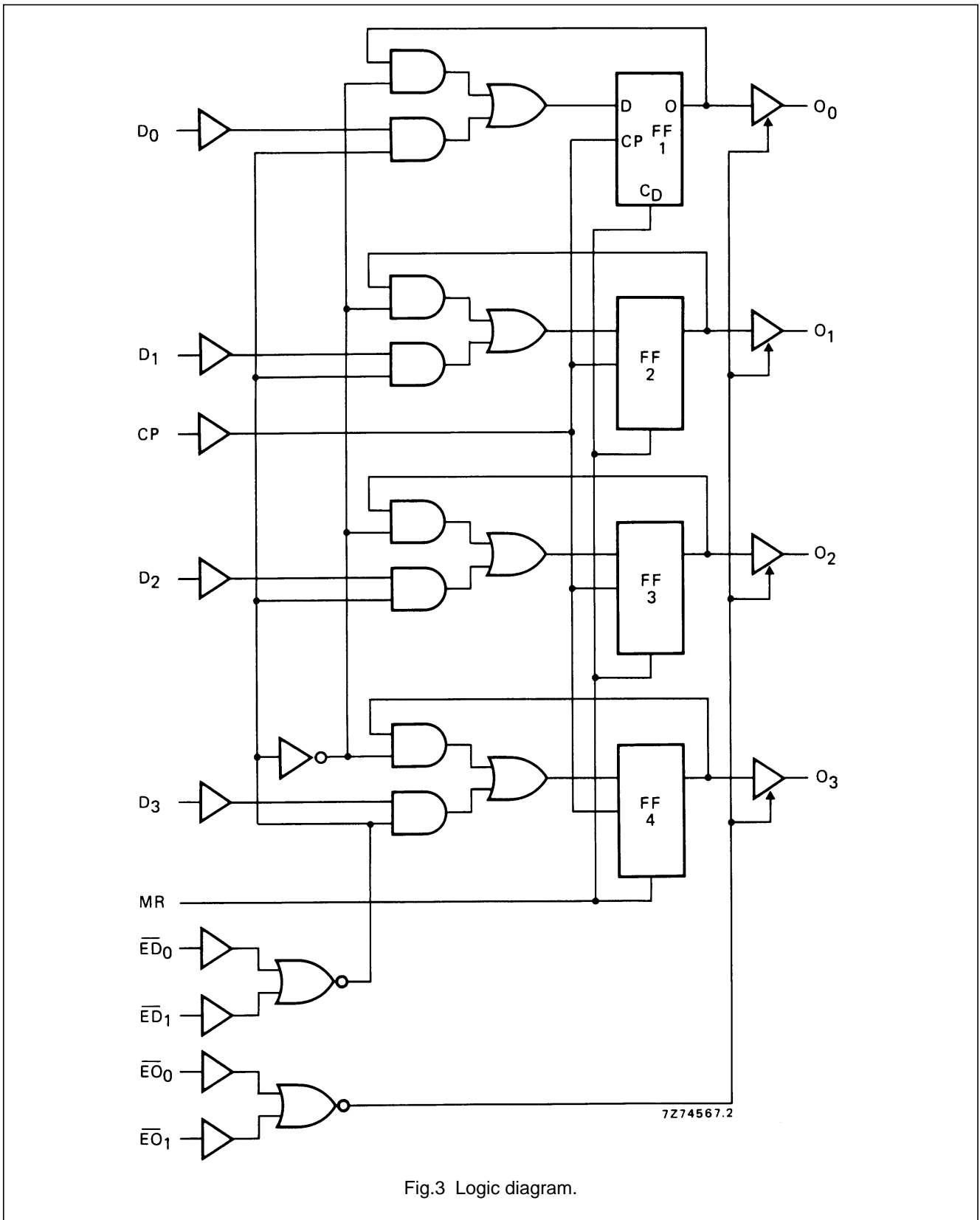

Quadruple D-type register with 3-state outputs

HEF4076B
MSI

FUNCTION TABLE

INPUTS					OUTPUTS
MR	CP	\overline{ED}_0	\overline{ED}_1	D_n	O_n
H	X	X	X	X	L
L	\nearrow	H	X	X	no change
L	\nearrow	X	H	X	no change
L	\nearrow	L	L	H	H
L	\nearrow	L	L	L	L
L	\searrow	X	X	X	no change

Notes

- $\overline{EO}_0 = \overline{EO}_1 = \text{LOW}$
When either \overline{EO}_0 or \overline{EO}_1 is HIGH, the outputs are disabled (high impedance OFF-state).
H = HIGH state (the more positive voltage)
L = LOW state (the less positive voltage)
X = state is immaterial
 \nearrow = positive-going transition
 \searrow = negative-going transition

AC CHARACTERISTICS

$V_{SS} = 0 \text{ V}$; $T_{amb} = 25 \text{ }^\circ\text{C}$; $C_L = 50 \text{ pF}$; input transition times $\leq 20 \text{ ns}$; see also waveforms Fig.4

	V_{DD} V	SYMBOL	MIN.	TYP.	MAX.	TYPICAL EXTRAPOLATION FORMULA								
Propagation delays	5	t_{PHL}		150	305	ns	$123 \text{ ns} + (0,55 \text{ ns/pF}) C_L$							
								CP \rightarrow O_n						
									HIGH to LOW					
	10													
								15						
									5	t_{PLH}	160	320	ns	$133 \text{ ns} + (0,55 \text{ ns/pF}) C_L$
	LOW to HIGH													
								10						
									15					
5	t_{PHL}	95	190	ns	$68 \text{ ns} + (0,55 \text{ ns/pF}) C_L$									
						MR \rightarrow O_n								
							HIGH to LOW							
10														
	15													
						5	t_{THL}			60	120	ns	$10 \text{ ns} + (1,0 \text{ ns/pF}) C_L$	
Output transition times														
	HIGH to LOW													
						10								
15														
	5	t_{TLH}	60	120	ns									$10 \text{ ns} + (1,0 \text{ ns/pF}) C_L$
						LOW to HIGH								
10														
	15													
		3-state propagation times				5	t_{PHZ}		50	105	ns			
Output disable times														
	$\overline{EO}_n \rightarrow O_n$													
													HIGH	
10														
	15													
			5	t_{PLZ}	45								90	ns
LOW														
	10													
		15												
30			65	ns										
	30						60	ns						

Quadruple D-type register with 3-state outputs

HEF4076B
MSI

	V _{DD} V	SYMBOL	MIN.	TYP.	MAX.	TYPICAL EXTRAPOLATION FORMULA
Output enable times $\overline{EO}_n \rightarrow O_n$ HIGH	5	t _{PZH}		65	130	ns
	10			30	55	ns
	15			20	40	ns
LOW	5	t _{PZL}		60	120	ns
	10			25	50	ns
	15			20	35	ns

AC CHARACTERISTICSV_{SS} = 0 V; T_{amb} = 25 °C; C_L = 50 pF; input transition times ≤ 20 ns

	V _{DD} V	SYMBOL	MIN.	TYP.	MAX.	TYPICAL EXTRAPOLATION FORMULA
Set-up times D _n → CP	5	t _{su}	10	-15	ns	see also waveforms Fig.4
	10		0	-10	ns	
	15		0	-5	ns	
$\overline{ED}_n \rightarrow CP$	5	t _{su}	0	-50	ns	
	10		0	-20	ns	
	15		0	-15	ns	
Hold times D _n → CP	5	t _{hold}	55	30	ns	
	10		20	10	ns	
	15		15	10	ns	
$\overline{ED}_n \rightarrow CP$	5	t _{hold}	25	-25	ns	
	10		10	-10	ns	
	15		5	-5	ns	
Minimum clock pulse width; LOW	5	t _{WCPL}	120	60	ns	
	10		45	20	ns	
	15		30	15	ns	
Minimum MR pulse width; HIGH	5	t _{WMRH}	55	25	ns	
	10		30	15	ns	
	15		20	10	ns	
Recovery time for MR	5	t _{RMR}	90	45	ns	
	10		35	15	ns	
	15		20	10	ns	
Maximum clock pulse frequency	5	f _{max}	4	8	MHz	
	10		11	22	MHz	
	15		16	32	MHz	

 Quadruple D-type register with 3-state outputs

 HEF4076B
 MSI

	V_{DD} V	TYPICAL FORMULA FOR P (μ W)	
Dynamic power	5	$2200 f_i + \sum (f_o C_L) \times V_{DD}^2$	where f_i = input freq. (MHz) f_o = output freq. (MHz) C_L = load capacitance (pF) $\sum (f_o C_L)$ = sum of outputs V_{DD} = supply voltage (V)
dissipation per	10	$9300 f_i + \sum (f_o C_L) \times V_{DD}^2$	
package (P)	15	$24\ 500 f_i + \sum (f_o C_L) \times V_{DD}^2$	

Quadruple D-type register with 3-state outputs

HEF4076B
MSI

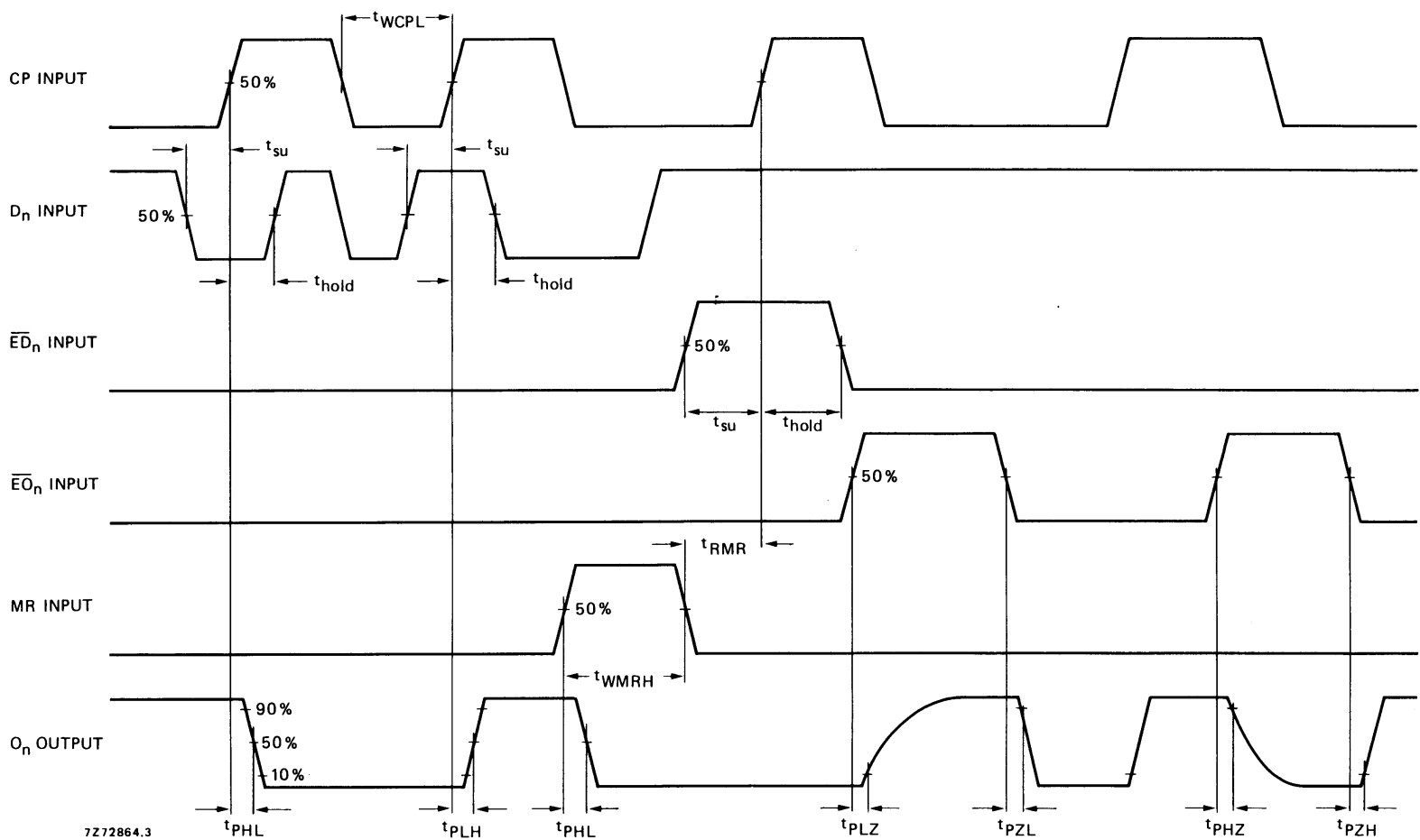

Fig.4 Waveforms showing propagation delays, output disable/enable times, minimum CP and MR pulse widths, set-up and hold times for D_n to CP and \overline{ED}_n to CP, and recovery time for MR. Set-up and hold times are shown as positive values but may be specified as negative values.

7272864.3