



Digital Alarm Clock

Overview

The LM8562 is a digital clock-use LSI having features such as easy setting, two alarms. Since the LM8562 is designed to be able to direct drive an LED panel of duplex type, the package in which the LM8562 is placed is a 28-pin shrink DIP with a small mounting area.

Features

- (1) Duplex LED display (LM8560-use LED panel usable)
- (2) Two alarms on chip (600 Hz, 1200 Hz)
- (3) Up, down/fast, slow time setting available (easy setting)
- (4) 12/24-hour mode, 50/60 Hz selectable (provided that it is impossible to select the combination of 24-hour mode and 60 Hz)
- (5) On-chip CR oscillator for backup use at the time of power failure
- (6) Power failure indicator
- (7) 59-minute alarm/sleep timer
- (8) 6-minute snooze function
- (9) Radio output function
- (10) P-channel ED MOS
- (11) Pin 28 dual-in-line shrink package
- (12) Wide operating voltage/operating temperature range
 $V_{DD} = -14$ to -8 V / -20 to $+70^{\circ}\text{C}$

Package Dimensions

unit : mm

3029A-DIP28S

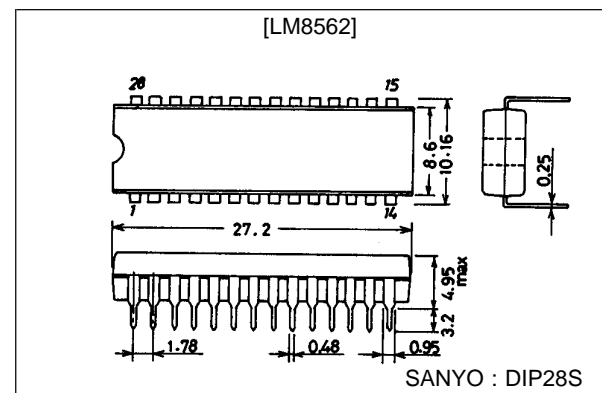

Specifications

Absolute Maximum Ratings at $T_a = 25^{\circ}\text{C}$, $V_{SS} = 0$ V

Parameter	Symbol	Conditions	Ratings	Unit
Supply voltage	V_{DD} max		-17.0 to $+0.3$	V
Input voltage	V_{IN}		-17.0 to $+0.3$	V
Output voltage	V_{OUT}		-17.0 to $+0.3$	V
Allowable power dissipation	P_d max	$T_a = 70^{\circ}\text{C}$	0.7	W
Operating temperature	T_{opr}		-20 to $+70$	$^{\circ}\text{C}$
Storage temperature	T_{stg}		-55 to $+125$	$^{\circ}\text{C}$

LM8562

Allowable Operating Conditions at $T_a = -20$ to $+70^\circ\text{C}$, $V_{SS} = 0$ V

Parameter	Symbol	Conditions	min	typ	max	Unit
Supply voltage	V_{DD}		-14		-8	V
Standby voltage	V_{ST}				-7.5	V
Input high-level voltage	V_{IH1}	50/60 Hz INPUT pin	$V_{SS}-1$		V_{SS}	V
Input low-level voltage	V_{IL1}				$V_{DD}+2$	V
Input high-level voltage	V_{IH2}	CR OSC pin	$V_{SS}-1$		V_{SS}	V
Input low-level voltage	V_{IL2}				$V_{DD} + 2$	V
Input high-level voltage	V_{IH3}	3-level input pins	$V_{SS} - 0.7$		V_{SS}	V
Input mid-level voltage	V_{IM}		$1/2 V_{DD} - 1$		$1/2 V_{DD} + 1$	V
Input low-level voltage	V_{IL3}		V_{DD}		$V_{DD} + 1$	V
Input high-level voltage	V_{IH4}	Input pins other than the above	$V_{SS} - 2$		V_{SS}	V
Input low-level voltage	V_{IL4}				$V_{DD} + 2$	V
Input level hold time	tH		10			ms
Input chattering time	tC		10			ms

Electrical Characteristics at $T_a = 25 \pm 2^\circ\text{C}$, $V_{SS} = 0$ V, $V_{DD} = -12$ V

Parameter	Symbol	Conditions	min	typ	max	Unit
Output high-level current	I_{OH1}	AM & 10'SHR ag & de pin, $V_{OUT} = V_{SS} - 2.0$ V	32		(Note1)	mA
Output OFF-state leakage current	I_{OF1}	$V_{OUT} = V_{DD}$			20	μA
Output high-level current	I_{OH2}	Segment output pins other than the above, $V_{OUT} = V_{SS} - 2.0$ V	16		(Note1)	mA
Output OFF-state leakage current	I_{OF2}	$V_{OUT} = V_{DD}$			20	μA
Output high-level current	I_{OH3}	ALM-1, ALM-2, RADIO OUTPUT pin, $V_{OUT} = V_{SS} - 2.0$ V	2			mA
Output OFF-state leakage current	I_{OF3}	$V_{OUT} = V_{DD}$			10	μA
Operating frequency	fop	50/60 Hz INPUT pin	DC		2000	Hz
Input high-level current	I_{IH1}	$V_{IH} = V_{SS}$			10	μA
Input low-level current	I_{IL1}	$V_{IL} = V_{DD}$	-10			μA
Input high-level current	I_{IH2}	CR OSC pin, $V_{IH} = V_{SS}$			10	μA
Input low-level current	I_{IL2}	$V_{IL} = V_{DD}$		60		μA
Input high-level current	I_{IH3}	3-level input pins, $V_{IH} = V_{SS}$	20		120	μA
Input low-level current	I_{IL3}	$V_{IL} = V_{DD}$	-120		-20	μA
Pull-down resistance	R_{PD}	3-level input pins, $V_{IN} = 1/2 V_{DD}$		1.0		$\text{M}\Omega$
Pull-up resistance	R_{PU}	$V_{IN} = 1/2 V_{DD}$		0.8		$\text{M}\Omega$
Operating current	I_{DD}	Output : No load	2	8	15	mA
Power failure detect circuit	V_{BU}		-7.5	-5.0		V
OSC stability	f_S	$V_{DD} = -9$ V \pm 10%	-10		10	%
OSC accuracy	f_A	$V_{DD} = -9$ V	-10		10	%
OSC frequency	f_{OSC}	$R = 180$ k Ω , $C = 3300$ pF		2400		Hz

Note 1 : The allowable segment current drain is 78 mA max. for AM & 10'SHR ag & de and 39 mA max. for other than AM & 10'SHR ag & de in the range of power dissipation 700 mW.

LM8562

Pin Assignment

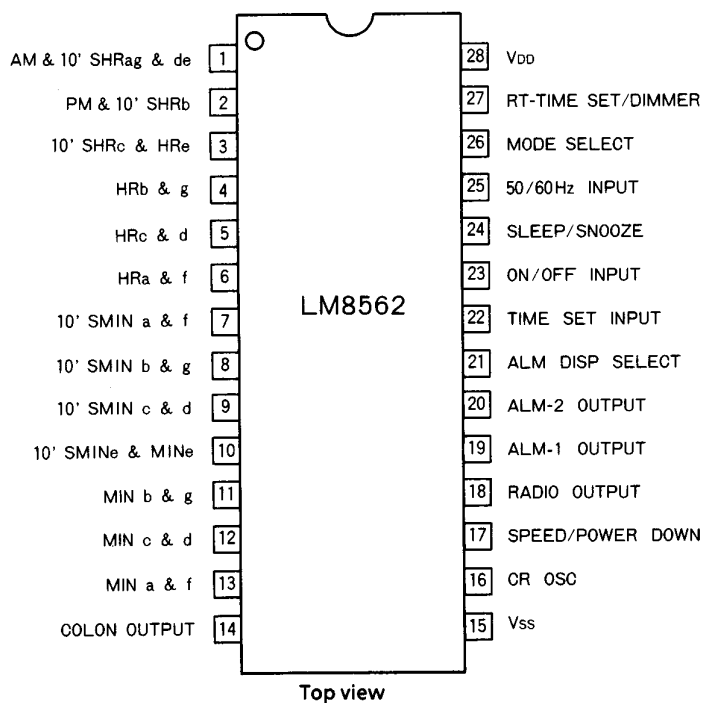

Pin Functions

1. 3-Level Input Pins

No.	Pin Name	Input Level		
		V _{SS}	OPEN	V _{DD}
17	SPEED/POWER DOWN	Test mode	Normal	Power-down mode
21	ALM-DISP SELECT	Alarm 2 display & setting	NOP	Alarm 1 display & setting
22	TIME SET INPUT	Slow-down (AC = fast-down)	NOP	Slow-up (AC = fast-up)
23	ON/OFF INPUT	ON	NOP	OFF
24	SLEEP/SNOOZE	Sleep display & sleep-in	NOP	Second display & snooze-in
26	MODE SELECT	24-hour mode, 50 Hz	12-hour mode, 50 Hz	12-hour mode, 60 Hz
27	RT-TIME SET/DIMMER	Time setting inhibit Dimmer display	Timer setting inhibit Normal display	Time setting enable Normal display

NOP : No operation

AC : Pulse input

2. Input/Output Pins

No.	Pin Name	Input Level	
		V _{SS}	V _{DD}
18	RADIO OUTPUT	—	When not used
19	ALM-1 OUTPUT	—	Alarm1 OFF
20	ALM-2 OUTPUT	—	Alarm2 OFF
16	CR OSC	1-pin OSC circuit	

3. Input Pins

No.25 50/60 Hz INPUT = 50 Hz or 60 Hz clock signal input

No.15, 28 V_{SS}, V_{DD} = Power supply pin

LM8562

4. Output Pins

No.	Pin Name	Drive Phase	
		1	2
1	AM & 10'SHR ag & de	AM 10'SHR ad	10'SHR eg
2	PM & 10'SHR b	PM	10'SHR b
3	10'SHR c & HR e	HR e	10'SHR c
4	HR b & g	HR g	HR b
5	HR c & d	HR d	HR c
6	HR a & f	HR f	HR a
7	10'SMIN a & f	10'SMIN a	10'SMIN f
8	10'SMIN b & g	10'SMIN b	10'SMIN g
9	10'SMIN c & d	10'SMIN c	10'SMIN d
10	10'SMIN e & MIN e	MIN e	10'SMIN e
11	MIN b & g	MIN g	MIN b
12	MIN c & d	MIN d	MIN c
13	MIN a & f	MIN f	MIN a
14	COLON OUTPUT	COLON	—

Display Mode

Select Pin		Display Mode	Digit No.			
ALM-DISP SELECT	SLEEP/SNOOZE INPUT		1	2	3	4
OPEN	OPEN	Time display	AM/PM 10's hour	Hour	10's minutes	Minutes
V _{DD}	OPEN	Alarm 1	AM/PM 10's hour	Hour	10's minutes	Minutes
V _{SS}	OPEN	Alarm 2	AM/PM 10's hour	Hour	10's minutes	Minutes
OPEN (V _{DD} , V _{SS})	V _{SS}	Sleep	Unlit	0	10's minutes	Minutes
OPEN (V _{DD} , V _{SS})	V _{DD}	second display	Unlit	Minutes	10's seconds	Seconds

Operation Description

1. Segment Output
The duplex LED panel can be direct driven by 13 segment output pins.
(Compatible with LM8560-use LED panel)
2. Colon Output
LED panel

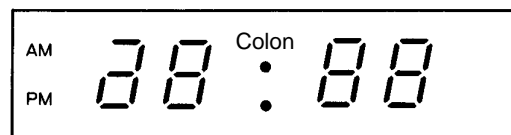

The drive phase is phase 1. The colon always flashes at 1 Hz rate.

3. OSC Circuit
By connecting a resistor and a capacitor with the CR INPUT pin, a 2.4 kHz OSC circuit is formed. The clock signal generated by the 2.4 kHz OSC circuit is used in the following cases.
 - (1) Used as the clock signal for the time counter, instead of 50/60 Hz INPUT, when the power-down mode is entered.
 - (2) Alarm sound (1200 Hz or 600 Hz) at the alarm signal output mode
 - (3) 1/25 duty clock signal while the dimmer is in operation
4. Power-Down Mode
 - (1) Since the backup OSC circuit holds the current time, the LM8562 starts operating immediately.
 - (2) The snooze function stops operating.
 - (3) The RADIO OUTPUT pin is brought to the OFF state.
 - (4) The control input is inhibited (except the following).
 - OFF INPUT
 - ALARM/SLEEP TIME SET INPUT at the time setting enable mode

LM8562

5. Alarm

The LM8562 contains two alarms on a 24-hour basis.

Alarm 1 Superposition of 600 Hz and 1 Hz

Alarm 2 Superposition of 1200 Hz and 1 Hz

6-minutes snooze

The alarm output duration time is 59 minutes. The 59-minute duration counter is common to the alarm 1, alarm2, and sleep timer.

6. Time Setting, Dimmer

The 3 level input RT-TIME SET/DIMMER INPUT pin provides the following functions.

RT-TIME SET/DIMMER INPUT Pin Input	Functions
V_{DD}	Time setting enable, normal display • Time, alarm time, sleep timer duration time setting enable
OPEN	Time setting inhibit, normal display • Time setting enable (except power-down mode)
V_{SS}	Time setting inhibit, dimmer display • Display brightness 50 Hz mode: 1/24 duty 60 Hz mode: 1/20 duty

The 3-level input TIME-SET INPUT pin provides the following operations.

TIME-SET INPUT Pin Input		Operations
V_{DD}	AC (50/60 Hz or more)	Fast-up
	DC (20 ms min.)	Slow-up
OPEN		No operation
V_{SS}	AC (50/60 Hz or more)	Fast-down
	DC (20 ms min.)	Slow-down

Setting Contents

- ① Fast-up/down 50/60 Hz rate
- ② Slow-up/down Immediately incremented/decremented ± 1 and counted up/down at a 2 Hz rate 0.5 to 1.0 second later

7. ON/OFF INPUT Pin

The 3-level input ON/OFF INPUT pin acts on the ALM-1, 2 RADIO OUTPUT pins as shown below.

Output Pin	ON-State Condition	Pause Conditions	OFF-State Conditions
ALM-1 OUTPUT	Alarm 1 setting time = Current time	Snooze-in	<ul style="list-style-type: none"> • ON/OFF INPUT = V_{SS} • ON/OFF INPUT = V_{DD} • Sleep-in • 59 minutes after the alarm 1 is turned ON • ALM-1 OUTPUT = V_{DD}
ALM-2 OUTPUT	Alarm 2 setting time = Current time	Snooze-in	<ul style="list-style-type: none"> • ON/OFF INPUT = V_{SS} • ON/OFF INPUT = V_{DD} • Sleep-in • 59 minutes after the alarm 2 is turned ON • ALM-2 OUTPUT = V_{DD}
RADIO OUTPUT	ON/OFF INPUT = V_{SS} (ON-state indicator : ON state)	—	<ul style="list-style-type: none"> • ON/OFF INPUT = V_{DD} • Power-down mode • Sleep-in (On-state indicator : OFF state)
	Sleep-in (Sleep indicator : ON state)	—	<ul style="list-style-type: none"> • ON/OFF INPUT = V_{SS} • ON/OFF INPUT = V_{DD} • Power-down mode (Sleep indicator : OFF state)

8. Sleep, Snooze Timer

The 3-level input SLEEP/SNOOZE INPUT pin operates as shown below.

SLEEP/SNOOZE INPUT Pin Input	Operation
V_{DD} (20 ms min.)	Snooze-in & seconds display mode • The alarm stops functioning for 6 to 7 minutes. • Seconds display
OPEN	No operation
V_{SS} (20 ms min.)	Sleep mode • The sleep counter is set to operate for 59 minutes. • Counted down automatically at a 2 Hz rate 1.5 to 2.0 seconds later • Fast/slow, up/down time setting available

LM8562

9. 50/60 Hz INPUT Pin

The LM8562 contains a Schmitt circuit so that a simple CR filter can be used to remove the noise of commercial frequency 50/60 Hz.

10. 12/24-Hour Mode, 50/60 Hz Select

The 3-level input MODE SELECT pin provides the following combinations.

MODE SELECT Pin Input	Select
V _{DD}	12-hour mode & 60 Hz
OPEN	12-hour mode & 50 Hz
V _{SS}	24-hour mode & 50 Hz

Sample Application Circuit

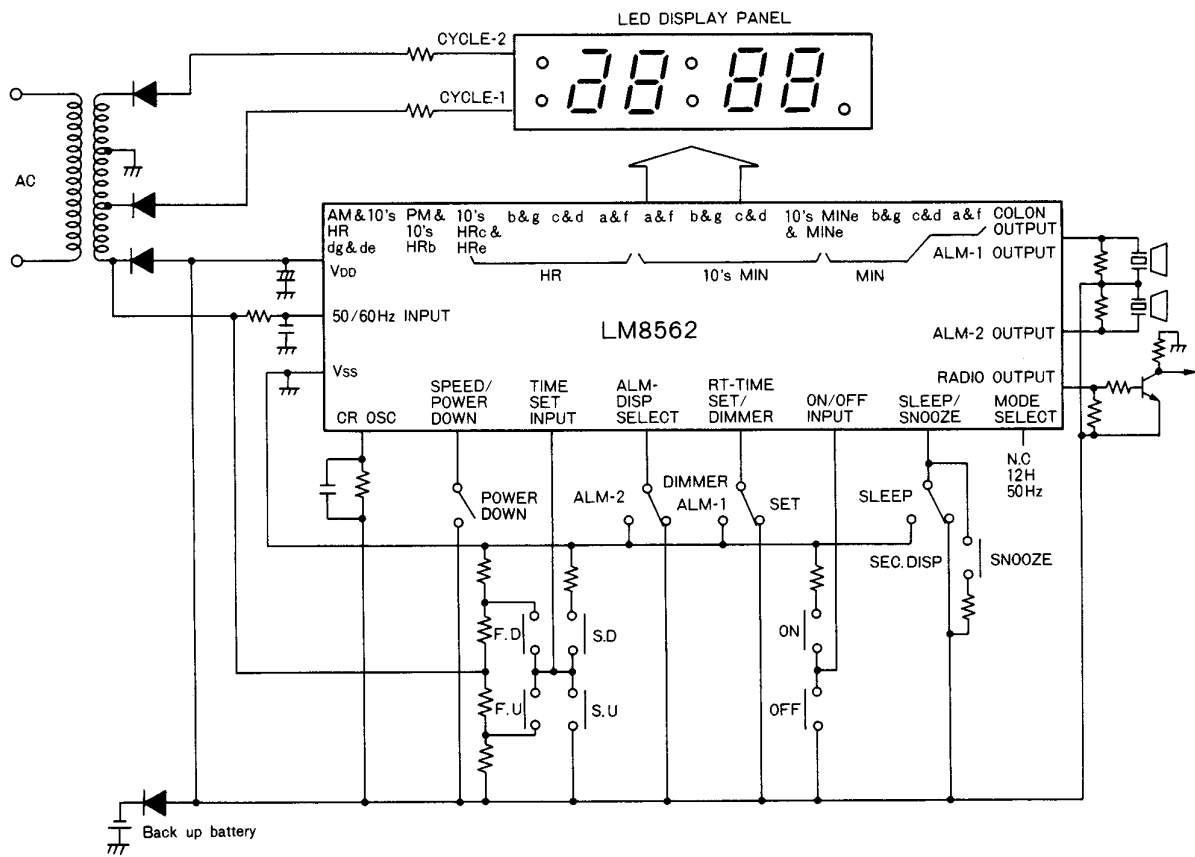

Block Diagram

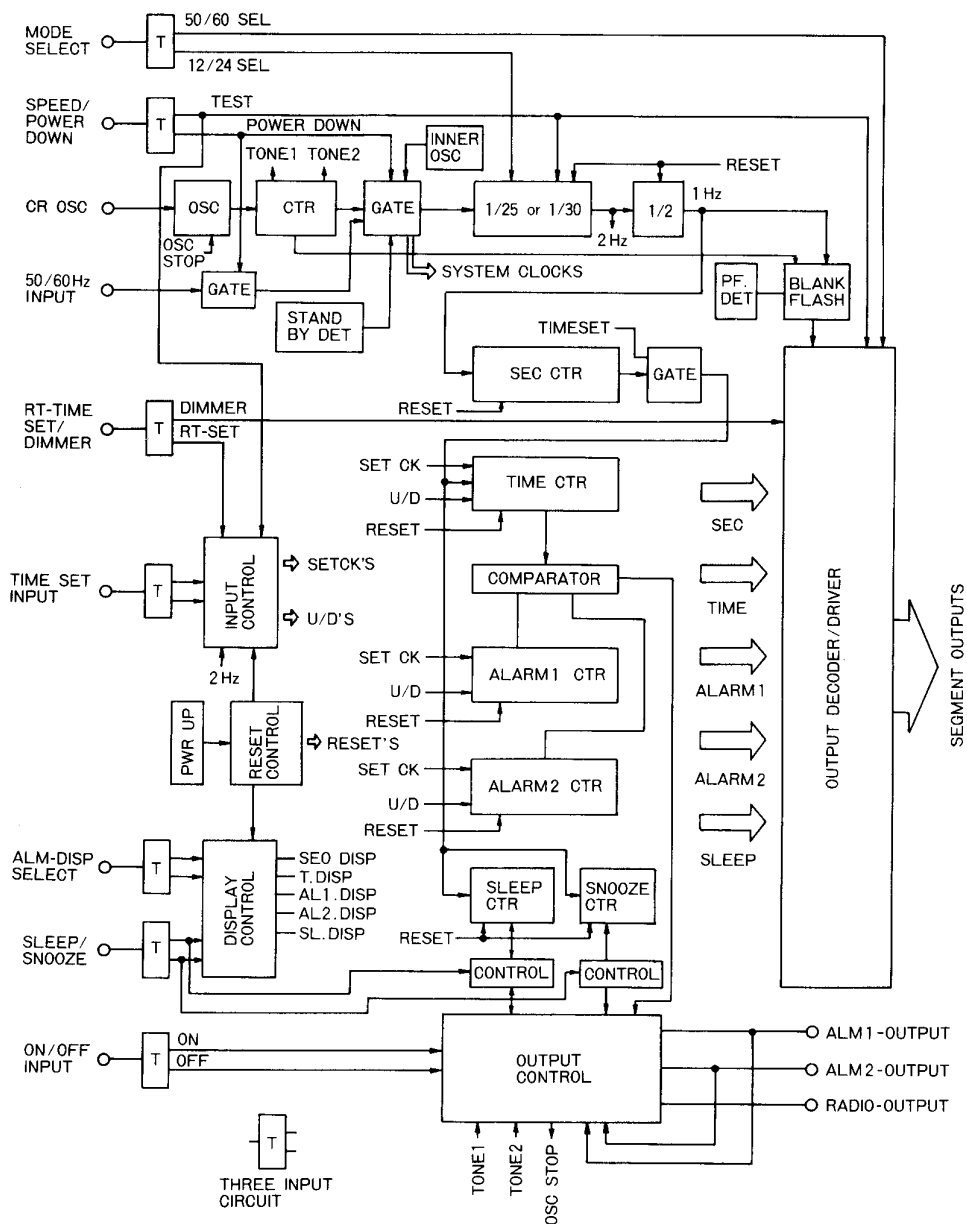

- No products described or contained herein are intended for use in surgical implants, life-support systems, aerospace equipment, nuclear power control systems, vehicles, disaster/crime-prevention equipment and the like, the failure of which may directly or indirectly cause injury, death or property loss.
- Anyone purchasing any products described or contained herein for an above-mentioned use shall:
 - ① Accept full responsibility and indemnify and defend SANYO ELECTRIC CO., LTD., its affiliates, subsidiaries and distributors and all their officers and employees, jointly and severally, against any and all claims and litigation and all damages, cost and expenses associated with such use:
 - ② Not impose any responsibility for any fault or negligence which may be cited in any such claim or litigation on SANYO ELECTRIC CO., LTD., its affiliates, subsidiaries and distributors or any of their officers and employees jointly or severally.
- Information (including circuit diagrams and circuit parameters) herein is for example only; it is not guaranteed for volume production. SANYO believes information herein is accurate and reliable, but no guarantees are made or implied regarding its use or any infringements of intellectual property rights or other rights of third parties.

This catalog provides information as of December, 1997. Specifications and information herein are subject to change without notice.