



SMTPB SERIES

TRISIL™

MAIN APPLICATIONS

Any sensitive equipment requiring protection against lightning strikes:

- ANALOG AND DIGITAL LINE CARDS
- MAIN DISTRIBUTION FRAMES
- TERMINALS AND TRANSMISSION EQUIPMENT
- GMS-TUBE REPLACEMENT

DESCRIPTION

The SMTPBxx series has been designed to protect telecommunication equipment against lightning and transient induced by AC power lines.

FEATURES

- BIDIRECTIONAL CROWBAR PROTECTION.
- BREAKDOWN VOLTAGE RANGE:
From 62 V To 270 V.
- HOLDING CURRENT: $I_H = 150 \text{ mA min}$
- REPETITIVE PEAK PULSE CURRENT :
 $I_{PP} = 100 \text{ A, } 10/1000 \mu\text{s}$.

BENEFITS

- NO AGEING AND NO NOISE
- IF DESTROYED, THE SMTPB FALLS INTO SHORT CIRCUIT, STILL ENSURING PROTECTION

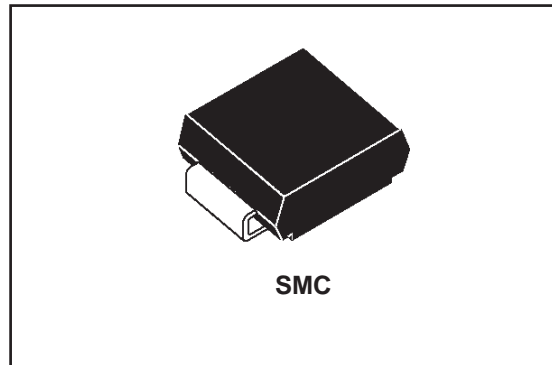

SMC

SCHEMATIC DIAGRAM

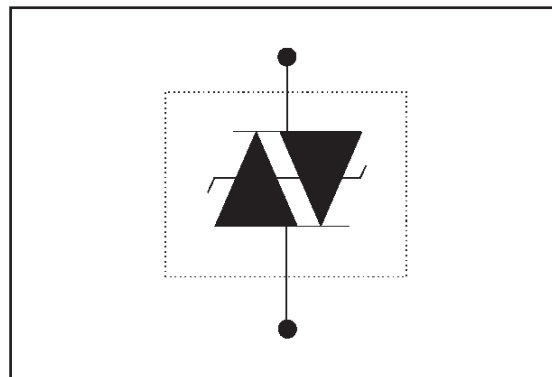

COMPLIES WITH THE FOLLOWING STANDARDS:	Peak Surge Voltage (V)	Voltage Waveform (μs)	Current Waveform (μs)	Admissible I_{pp} (A)	Necessary Resistor (Ω)
CCITT K20	4000	10/700	5/310	100	-
VDE0433	4000	10/700	5/310	100	-
VDE0878	4000	1.2/50	1/20	100	-
IEC-1000-4-5	level 4 level 4	10/700 1.2/50	5/310 8/20	100 100	- -
FCC Part 68, lightning surge type A	1500 800	10/160 10/560	10/160 10/560	200 100	- -
FCC Part 68, lightning surge type B	100	5/320	5/320	25	-
BELLCORE TR-NWT-001089 First level	2500 1000	2/10 10/1000	2/10 10/1000	500 100	- -
BELLCORE TR-NWT-001089 Second level	500	2/10	2/10	500	-
CNET I31-24	4000	0.5/700	0.8/310	100	-

SMTPBxxx

ABSOLUTE MAXIMUM RATINGS (T_{amb} = 25°C)

Symbol	Parameter		Value	Unit
P	Power dissipation	T _{lead} = 50 °C	5	W
I _{PP}	Peak pulse current	10/1000 μs 8/20 μs 2/10 μs	100 250 500	A
I _{TSM}	Non repetitive surge peak on-state current	tp = 20 ms	50	A
dV/dt	Critical rate of rise of off-state voltage	V _{RM}	5	KV/μs
T _{stg} T _j	Storage temperature range Maximum junction temperature		- 55 to + 150 + 150	°C °C
T _L	Maximum lead temperature for soldering during 10 s.		+ 260	°C

THERMAL RESISTANCES

Symbol	Parameter	Value	Unit
R _{th} (j-l)	Junction to leads	20	°C/W
R _{th} (j-a)	Junction to ambient. On printed circuit with standard footprint dimensions.	75	°C/W

ELECTRICAL CHARACTERISTICS (T_{amb} = 25°C)

Symbol	Parameter
V _{RM}	Stand-off voltage
I _{RM}	Leakage current at stand-off voltage
V _R	Continuous Reverse voltage
V _{BR}	Breakdown voltage
V _{BO}	Breakover voltage
I _H	Holding current
I _{BO}	Breakover current
I _{PP}	Peak pulse current
C	Capacitance

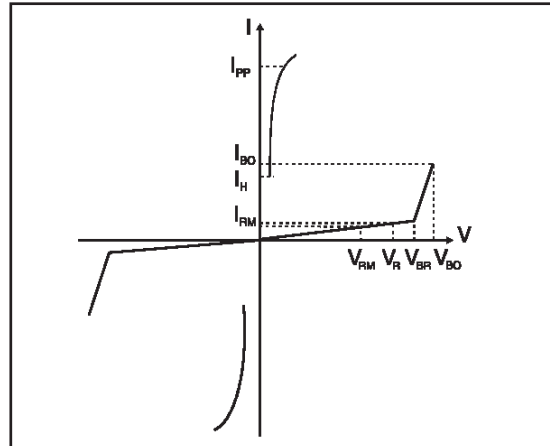

Type	Marking	I _{RM} @ V _{RM}		I _R @ V _R		V _{BO} @ I _{BO}		I _H	C
		max.		max. note1		max. note2		min. note3	typ. note4
	Laser	μA	V	μA	V	V	mA	mA	pF
SMTPB62	W07	2	56	50	62	82	800	150	160
SMTPB68	W11	2	61	50	68	90	800	150	160
SMTPB120	W21	2	108	50	120	160	800	150	140
SMTPB200	W31	2	180	50	200	267	800	150	130
SMTPB270	W43	2	243	50	270	360	800	150	120

All parameters tested at 25°C, except where indicated.

Note 1: I_R measured at V_R guarantees V_{BRmin} ≥ V_R

Note 2: Measured at 50 Hz (1 cycle) - See test circuit 1.

Note 3: See test circuit 2.

Note 4: V_R = 1V, F = 1MHz. Refer to fig 3 for C versus V_R.

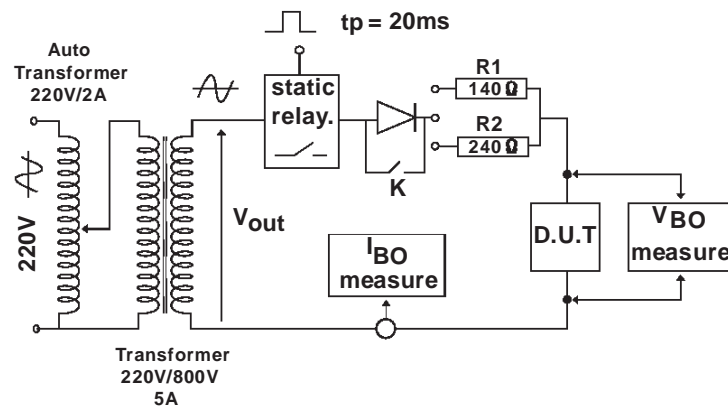
TEST CIRCUIT 1 FOR I_{BO} and V_{BO} parameters :**TEST PROCEDURE :**

- Pulse Test duration ($t_p = 20\text{ms}$):
 - For Bidirectional devices = Switch K is closed
 - For Unidirectional devices = Switch K is open.
- V_{OUT} Selection
 - Device with $V_{BO} < 200$ Volt
 - $V_{OUT} = 250 V_{RMS}$, $R_1 = 140 \Omega$.
 - Device with $V_{BO} \geq 200$ Volt
 - $V_{OUT} = 480 V_{RMS}$, $R_2 = 240 \Omega$.

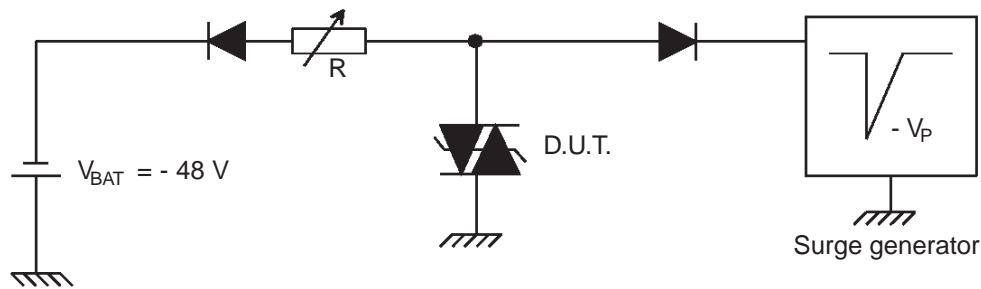
TEST CIRCUIT 2 for I_H parameter.

This is a GO-NOGO Test which allows to confirm the holding current (I_H) level in a functional test circuit.

TEST PROCEDURE :

- 1) Adjust the current level at the I_H value by short circuiting the AK of the D.U.T.
- 2) Fire the D.U.T with a surge Current : $I_{pp} = 10A$, $10/1000\mu\text{s}$.
- 3) The D.U.T will come back off-state within 50 ms max.

Fig. 1: Non repetitive surge peak on-state current versus overload duration (T_j initial=25°C).

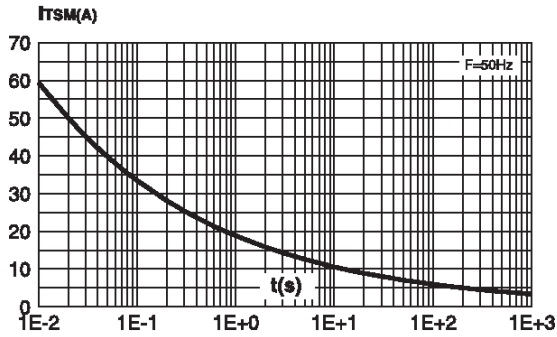

Fig. 2: Relative variation of holding current versus junction temperature.

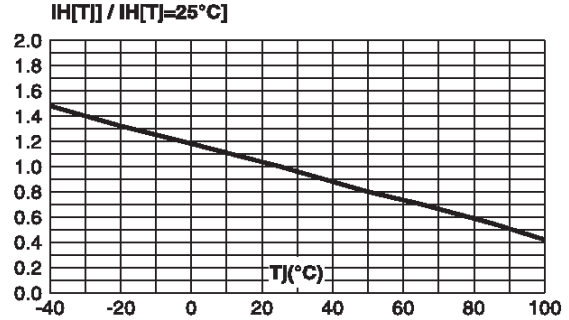

Fig. 3: Relative variation of junction capacitance versus reverse applied voltage (typical values). Note: For V_{RM} upper than 56V, the curve is extrapolated (dotted line).

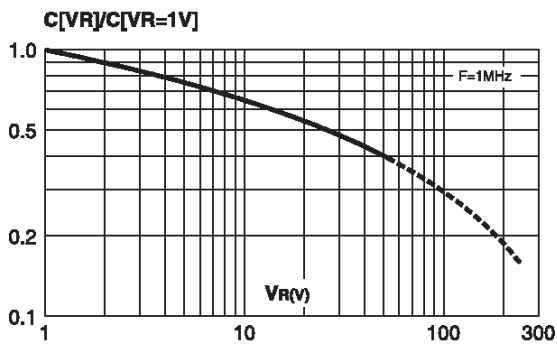

Fig. 4: On-state voltage versus on-state current (typical values).

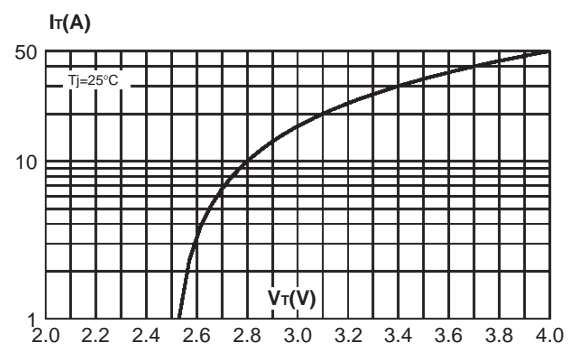
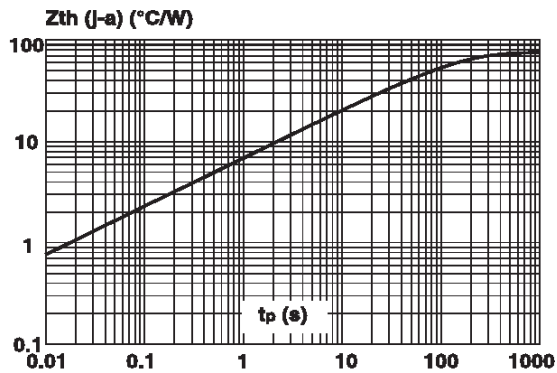
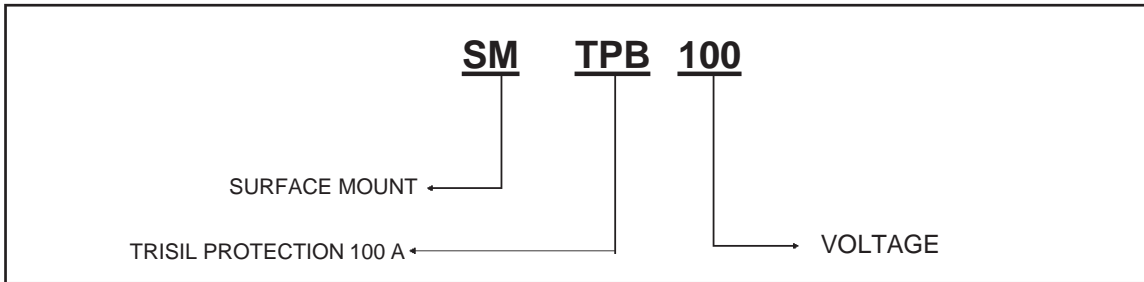

Fig. 5: Transient thermal impedance junction to ambient versus pulse duration (for FR4 PC Board with recommended pad layout).



ORDER CODE



Marking : Logo, date code, type code.

PACKAGE MECHANICAL DATA.

SMC

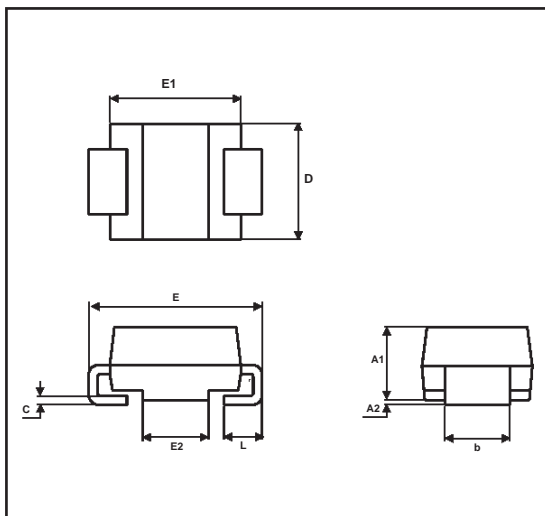

REF.	DIMENSIONS			
	Millimeters		Inches	
	Min.	Max.	Min.	Max.
A1	1.90	2.45	0.075	0.096
A2	0.05	0.20	0.002	0.008
b	2.90	3.2	0.114	0.126
c	0.15	0.41	0.006	0.016
E	7.75	8.15	0.305	0.321
E1	6.60	7.15	0.260	0.281
E2	4.40	4.70	0.173	0.185
D	5.55	6.25	0.218	0.246
L	0.75	1.60	0.030	0.063

FOOTPRINT DIMENSIONS (in millimeters)

SMC

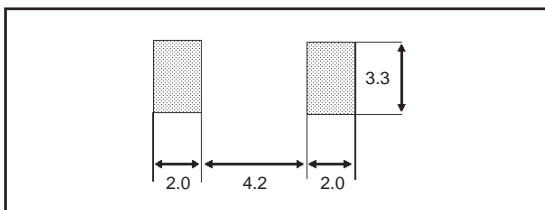

Packaging : Standard packaging is in tape and reel
Weight : 0.25g.

Information furnished is believed to be accurate and reliable. However, STMicroelectronics assumes no responsibility for the consequences of use of such information nor for any infringement of patents or other rights of third parties which may result from its use. No license is granted by implication or otherwise under any patent or patent rights of STMicroelectronics. Specifications mentioned in this publication are subject to change without notice. This publication supersedes and replaces all information previously supplied. STMicroelectronics products are not authorized for use as critical components in life support devices or systems without express written approval of STMicroelectronics.

The ST logo is a registered trademark of STMicroelectronics

© 1999 STMicroelectronics - Printed in Italy - All rights reserved.

STMicroelectronics GROUP OF COMPANIES

Australia - Brazil - China - Finland - France - Germany - Hong Kong - India - Italy - Japan - Malaysia
 Malta - Morocco - Singapore - Spain - Sweden - Switzerland - United Kingdom - U.S.A.

<http://www.st.com>

