

# Cree<sup>®</sup> LED Module LMR4 with TrueWhite<sup>®</sup> Technology

**A fast, proven way to realize the promise of LED Lighting**

## Data Sheet

Cree LED Modules provide a simple solution for lighting designers and manufacturers to adopt best-in-class LED lighting from Cree. The LMR series continues Cree's history of innovation in LEDs for lighting applications and provides a comprehensive solution including Cree's patented TrueWhite Technology to achieve an industry-leading combination of light quality and efficacy. This versatile LED lighting module allows design flexibility with the beautiful color and efficacy of Cree TrueWhite technology.

A comprehensive design guide and CAD files are available through the Cree Module sales team. This data sheet is intended to introduce you to the features and benefits of the LMR4 module. The design guide and solid model must be referenced for the thermal, mechanical and optical requirements of a successful LMR4 product design.

## FEATURES

- Cree TrueWhite technology
- Comprehensive solution with driver electronics, optics and core thermals
- 700 & 1000 lm @ 2700, 3000, 3500, 4000 K CCT
- Supports dimming to 5% of rated light output
- Designed to last at least 35,000 hours at L70
- Versatile form factor
- Cree IES LM-80 data in support of U. S. DOE ENERGY STAR<sup>®</sup> qualification
- The LMR4 (120 V) is UL-recognized and California Title 24-compliant, and the LMR4 (230 V) complies with multiple international standards

The Cree LED Module LMR4 with Cree TrueWhite Technology is the ideal choice for commercial lighting applications where high CRI, luminous flux and efficacy are required, such as restaurants, retail and hospitality lighting.

Cree TrueWhite technology:

- A better way to generate white light that utilizes a patented mixture of unsaturated yellow and saturated red LEDs.
- Proprietary optical system utilizes a unique combination of reflective and refractive optical components to achieve a uniform, comfortable appearance. Pixelation and direct view of LEDs is eliminated.
- Technology benefit - high CRI and efficacy allows customers to avoid having to make tradeoffs between energy efficiency and light quality as compared to other lighting alternatives.
- Marketing benefit - Cree logo on lens enables brand marketing value on final design.



## Characteristics

The following table provides several base order codes for the Cree LED module LMR4, as well as a description of the order-code nomenclature.

CCT*	Nominal Luminous Flux (lm)	CRI	Input Power (W)	Input Voltage/ Frequency** (Hz)	Power Factor	Order Code
4000	700	90	12	120 V/60	>.80	LMR040-0700-40F9-10100TW
4000	700	90	12	230 V/50	>.90	LMR040-0700-40F9-20100TW
3500	700	90	12	120 V/60	>.80	LMR040-0700-35F9-10100TW
3500	700	90	12	230 V/50	>.90	LMR040-0700-35F9-20100TW
3000	700	90	12	120 V/60	>.80	LMR040-0700-30F9-10100TW
3000	700	90	12	230 V/50	>.90	LMR040-0700-30F9-20100TW
2700	700	90	12	120 V/60	>.80	LMR040-0700-27F9-10100TW
2700	700	90	12	230 V/50	>.90	LMR040-0700-27F9-20100TW
4000	1000	90	15	120 V/60	>.95	LMR040-1000-40F9-10100TW
4000	1000	90	15	230 V/50	>.95	LMR040-1000-40F9-20100TW
3500	1000	90	15	120 V/60	>.95	LMR040-1000-35F9-10100TW
3500	1000	90	15	230 V/50	>.95	LMR040-1000-35F9-20100TW
3000	1000	90	15	120 V/60	>.95	LMR040-1000-30F9-10100TW
3000	1000	90	15	230 V/50	>.95	LMR040-1000-30F9-20100TW
2700	1000	90	15	120 V/60	>.95	LMR040-1000-27F9-10100TW
2700	1000	90	15	230 V/50	>.95	LMR040-1000-27F9-20100TW

\* Refer to section below on chromaticity for more details

\*\* Input ranges are 110–130 V/60–70 Hz and 220–240 V/50–60 Hz

Note: Cree maintains a tolerance of +/- 7% on flux and power measurements

## Form Factor

The Cree LED module LMR4 is constructed with a durable machined-aluminum housing and comes complete with an integrated thermal management system. This system conducts heat away from LEDs and transfers it to the mounting plate junction, providing luminaire designers with the flexibility to further optimize their thermal design.

Form factor and measurements are shown below, and additional details are also available by downloading the STEP file from [www.cree.com/modules](http://www.cree.com/modules). The standard product configuration consists of the module with the mounting plate attached. A custom-fit heat sink is also available and can be ordered separately (part number LMR040-HS00-0000-0000001).

The weight of the module mounting plate is approximately 250 grams and 150 grams for the heat sink.



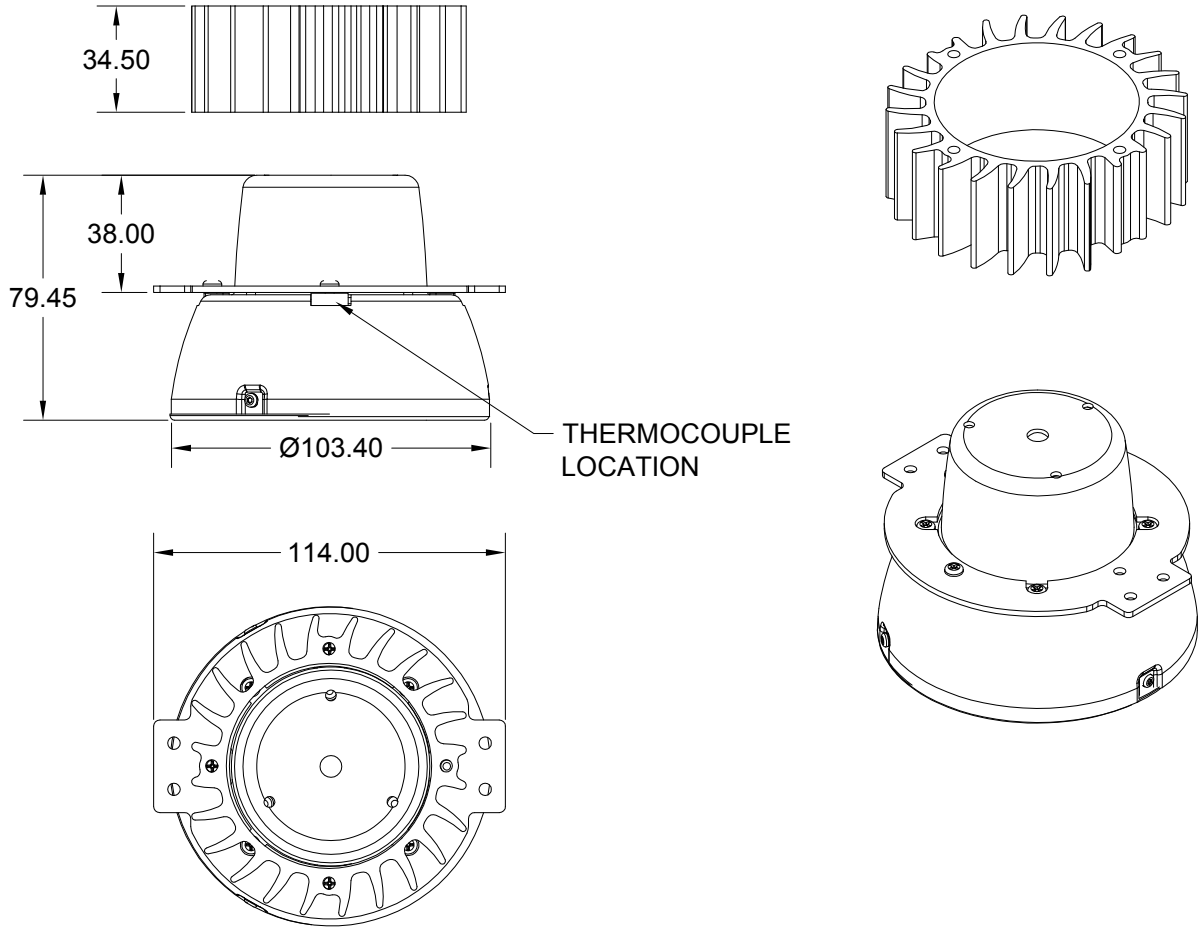

### Thermal Management Guidelines

Acceptable ambient starting and operating temperatures of the Cree LED Module LMR4 are between 0°C and 50°C. The lifetime and performance estimates described in this document require that the Tc (case temperature) limit stated in this Thermal Management Guidelines section is adhered to and that only the modifications described in this document be implemented.

The LED module is flexible; use of the optional heat sink depends on the thermal path options available in your design requirements. Secondary optics added to the module will reduce the light output and could also alter the color characteristics of the final luminaire design.

The Cree LED module LMR4 is designed to perform in a variety of environments; however, the LED module lifetime is highly dependent upon the Tc (case temperature). To achieve lifetime and performance estimates, and maintain the warranty, the final design cannot exceed 70°C at thermal equilibrium, based on the thermocouple location shown in the Form Factor section below and tested in situ.

## Photometry

The following photometry results are design values. Absolute photometric testing at independent testing labs can be expected to vary by  $\pm 7\%$ .

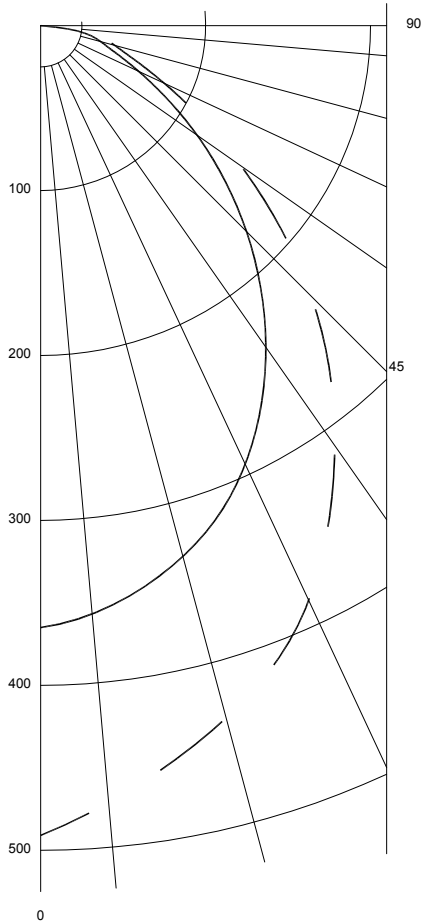

————— 700 lm  
 - - - - - 1000 lm

### Intensity Candlepower Summary

Angle (°)	700 lm Mean CP	1000 lm Mean CP
0	365	491
5	362	476
15	340	441
25	300	395
35	245	318
45	184	244
55	124	159
65	71	90
75	37	46
85	27	33
90	0	0

### 700-Lumen Version Zonal Lumens Summary

Zone	Lumens	%Fixt
0-30	242	35
0-40	381	55
0-60	607	87
0-90	700	100

### 1000-Lumen Version Zonal Lumens Summary

Zone	Lumens	%Fixt
0-30	255	24
0-40	451	43
0-60	817	77
0-90	1057	100



## Chromaticity

The Cree LED Module LMR4 provides high color consistency around the specified color temperature. Individual LEDs are tested and matched in order to meet the designed chromaticity specification, which is defined by the following bounding coordinates.

Color Temp Code	CCT (K)	x	y
40F	4000	0.3722	0.3749
		0.3823	0.3706
		0.3916	0.3857
		0.3814	0.3893
35F	3500	0.3975	0.3858
		0.4074	0.3823
		0.4175	0.3979
30F	3000	0.4074	0.4016
		0.4236	0.3969
		0.4334	0.3933
		0.4443	0.4093
27F	2700	0.4343	0.4132
		0.4473	0.4038
		0.4570	0.4001
		0.4684	0.4164
		0.4586	0.4204

## Order Codes

