



NC7SZ08 TinyLogic® UHS 2-Input AND Gate

Features

- Space saving SOT23 or SC70 5-lead package
- Ultra small MicroPak™ Pb-Free leadless package
- Ultra High Speed; t_{PD} 2.7ns Typ. into 50pF at 5V V_{CC}
- High Output Drive; $\pm 24mA$ at 3V V_{CC}
- Broad V_{CC} Operating Range; 1.65V to 5.5V
- Matches the performance of LCX when operated at 3.3V V_{CC}
- Power down high impedance inputs/output
- Overvoltage tolerant inputs facilitate 5V to 3V translation
- Patented noise/EMI reduction circuitry implemented
- All packages are Pb-Free

General Description

The NC7SZ08 is a single 2-Input AND Gate from Fairchild's Ultra High Speed Series of TinyLogic®. The device is fabricated with advanced CMOS technology to achieve ultra high speed with high output drive while maintaining low static power dissipation over a very broad V_{CC} operating range. The device is specified to operate over the 1.65V to 5.5V V_{CC} range. The inputs and output are high impedance when V_{CC} is 0V. Inputs tolerate voltages up to 6V independent of V_{CC} operating voltage.

Ordering Information

Order Number	Package Number	Product Code Top Mark	Pb-Free	Package Description	Supplied As
NC7SZ08M5X	MA05B	7Z08	Yes	5-Lead SOT23, JEDEC MO-178, 1.6mm	3k Units on Tape and Reel
NC7SZ08M5_NL ⁽¹⁾	MA05B	7Z08	Yes	Pb-Free 5-Lead SOT23, JEDEC MO-178, 1.6mm	250 Units on Tape and Reel
NC7SZ08M5X_NL ⁽²⁾	MA05B	7Z08	Yes	Pb-Free 5-Lead SOT23, JEDEC MO-178, 1.6mm	3k Units on Tape and Reel
NC7SZ08P5X	MAA05A	Z08	Yes	5-Lead SC70, EIAJ SC-88a, 1.25mm Wide	3k Units on Tape and Reel
NC7SZ08P5_NL ⁽¹⁾	MAA05A	Z08	Yes	Pb-Free 5-Lead SC70, EIAJ SC-88a, 1.25mm Wide	250 Units on Tape and Reel
NC7SZ08P5X_NL ⁽²⁾	MAA05A	Z08	Yes	5-Lead SC70, EIAJ SC-88a, 1.25mm Wide	3k Units on Tape and Reel
NC7SZ08L6X	MAC06A	GG	Yes	Pb-Free 6-Lead MicroPak, 1.0mm Wide	5k Units on Tape and Reel

Notes:

Pb-Free package per JEDEC J-STD-020B.

1. “_NL” indicates lead-free product (per JEDEC J-STD-020B).
2. “_NL” indicates lead-free product (per JEDEC J-STD-020B). Device is available in Tape and Reel only.

TinyLogic® is a registered trademark of Fairchild Semiconductor Corporation.
MicroPak™ is a trademark of Fairchild Semiconductor Corporation.

Logic Symbol

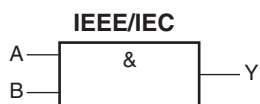

Pin Descriptions

Pin Name	Description
A, B	Data Inputs
Y	Outputs
NC	No Connect

Connection Diagrams

Pin Assignment for SC70 and SOT23

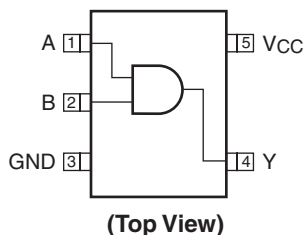

Pad Assignments for MicroPak

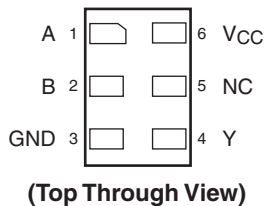

Function Table

$$Y = AB$$

Inputs		Output
A	B	Y
L	L	L
L	H	L
H	L	L
H	H	H

H = HIGH Logic Level L = LOW Logic Level

Absolute Maximum Ratings

The “Absolute Maximum Ratings” are those values beyond which the safety of the device cannot be guaranteed. The device should not be operated at these limits. The parametric values defined in the Electrical Characteristics tables are not guaranteed at the absolute maximum ratings. The “Recommended Operating Conditions” table will define the conditions for actual device operation.

Symbol	Parameter	Rating
V_{CC}	Supply Voltage	-0.5V to +6V
V_{IN}	DC Input Voltage	-0.5V to +6V
V_{OUT}	DC Output Voltage	-0.5V to +6V
I_{IK}	DC Input Diode Current @ $V_{IN} < -0.5V$ @ $V_{IN} > 6V$	-50mA +20mA
I_{OK}	DC Output Diode Current @ $V_{OUT} < -0.5V$ @ $V_{OUT} > 6V, V_{CC} = GND$	-50mA +20mA
I_{OUT}	DC Output Current	±50mA
I_{CC}/I_{GND}	DC V_{CC}/GND Current	±50mA
T_{STG}	Storage Temperature	-65°C to +150°C
T_J	Junction Temperature under Bias	150°C
T_L	Junction Lead Temperature (Soldering, 10 seconds)	260°C
P_D	Power Dissipation @ +85°C SOT23-5 SC70-5	200mW 150mW

Recommended Operating Conditions⁽³⁾

Symbol	Parameter	Rating
V_{CC}	Supply Voltage Operation	1.65V to 5.5V
V_{CC}	Supply Voltage Data Retention	1.5V to 5.5V
V_{IN}	Input Voltage	0V to 5.5V
V_{OUT}	Output Voltage	0V to V_{CC}
T_A	Operating Temperature	-40°C to +85°C
t_r, t_f	Input Rise and Fall Time $V_{CC} = 1.8V, 2.5V \pm 0.2V$ $V_{CC} = 3.3V \pm 0.3V$ $V_{CC} = 5.0V \pm 0.5V$	0ns/V to 20ns/V 0ns/V to 10ns/V 0ns/V to 5ns/V
θ_{JA}	Thermal Resistance SOT23-5 SC70-5	300°C/W 425°C/W

Notes:

3. Unused inputs must be held HIGH or LOW. They may not float.

DC Electrical Characteristics

Symbol	Parameter	Conditions	V _{CC} (V)	T _A =					Units
				+25°C			-40°C to +85°C		
				Min.	Typ.	Max.	Min.	Max.	
V _{IH}	HIGH Level Input Voltage		1.65 to 1.95	0.75 x V _{CC}			0.75 x V _{CC}		V
			2.3 to 5.5	0.7 x V _{CC}			0.7 x V _{CC}		
V _{IL}	LOW Level Input Voltage		1.65 to 1.95			0.25 x V _{CC}		0.25 x V _{CC}	V
			2.3 to 5.5			0.3 x V _{CC}		0.3 x V _{CC}	
V _{OH}	HIGH Level Output Voltage V _{IN}	V _{IN} = V _{IH} , I _{OH} = -100μA	1.65	1.55	1.65		1.55		V
			1.8	1.7	1.8		1.7		
			2.3	2.2	2.3		2.2		
			3.0	2.9	3.0		2.9		
			4.5	4.4	4.5		4.4		
		I _{OH} = -4mA	1.65	1.29	1.52		1.29		
		I _{OH} = -8mA	2.3	1.9	2.15		1.9		
		I _{OH} = -16mA	3.0	2.5	2.80		2.4		
		I _{OH} = -24mA	3.0	2.4	2.68		2.3		
I _{OH} = -32mA	4.5	3.9	4.20		3.8				
V _{OL}	LOW Level Output Voltage	V _{IN} = V _{IL} , I _{OL} = 100μA	1.65		0.0	0.1		0.1	V
			1.8		0.0	0.1		0.1	
			2.3		0.0	0.1		0.1	
			3.0		0.0	0.1		0.1	
			4.5		0.0	0.1		0.1	
		I _{OL} = 4mA	1.65		0.08	0.24		0.24	
		I _{OL} = 8mA	2.3		0.10	0.3		0.3	
		I _{OL} = 16mA	3.0		0.15	0.4		0.4	
		I _{OL} = 24mA	3.0		0.22	0.55		0.55	
I _{OL} = 32mA	4.5		0.22	0.55		0.55			
I _{IN}	Input Leakage Current	V _{IN} = 5.5V, GND	0 to 5.5			±1		±10	μA
I _{OFF}	Power Off Leakage Current	V _{IN} or V _{OUT} = 5.5V	0.0			1		10	μA
I _{CC}	Quiescent Supply Current	V _{IN} = 5.5V, GND	1.65 to 5.5			2.0		20	μA

AC Electrical Characteristics

Symbol	Parameter	Conditions	V _{CC} (V)	T _A =					Units	Figure Number
				+25°C			-40°C to +85°C			
				Min.	Typ.	Max.	Min.	Max.		
t _{PLH} , t _{PHL}	Propagation Delay	C _L = 15pF, R _L = 1MΩ	1.65	2.0	6.3	12	2.0	12.7	ns	Figure 1 Figure 3
			1.8	2.0	5.2	10	2.0	10.5		
			2.5±0.2	0.8	3.4	7	0.8	7.5		
			3.3±0.3	0.5	2.6	4.7	0.5	5.0		
			5.0±0.5	0.5	2.2	4.1	0.5	4.4		
		C _L = 50pF, R _L = 500Ω	3.3±0.3	1.5	3.3	5.2	1.5	5.5		
			5.0±0.5	0.8	2.7	4.5	0.8	4.8		
C _{IN}	Input Capacitance		0		4				pF	
C _{PD}	Power Dissipation Capacitance	Note 2	3.3		20				pF	Figure 2
			5.0		25					

Note:

2. CPD is defined as the value of the internal equivalent capacitance which is derived from dynamic operating current consumption (I_{CCD}) at no output loading and operating at 50% duty cycle. (See Figure 2.) C_{PD} is related to I_{CCD} dynamic operating current by the expression:

$$I_{CCD} = (C_{PD})(V_{CC})(f_{IN}) + (I_{CC \text{ static}})$$

AC Loading and Waveforms

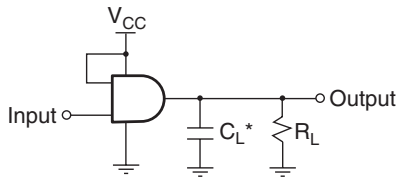

*C_L includes load and stray capacitance.
Input PRR = 1.0MHz; t_w = 500ns

Figure 1. AC Test Circuit

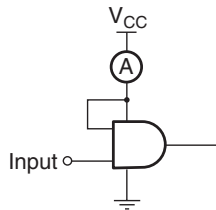

Input = AC Waveform; t_r, t_f = 1.8ns;
PRR = 10MHz; Duty Cycle = 50%

Figure 2. I_{CCD} Test Circuit

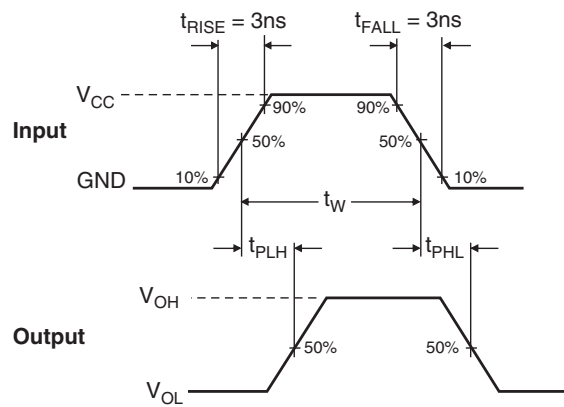

Figure 3. AC Waveforms

Tape and Reel Specification

Tape Format for SC70 and SOT23

Package Designator	Tape Section	Number Cavities	Cavity Status	Cover Tape Status
M5X, P5X	Leader (Start End)	125 (typ)	Empty	Sealed
	Carrier	3000	Filled	Sealed
	Trailer (Hub End)	75 (typ)	Empty	Sealed

Tape Dimension inches (millimeters)

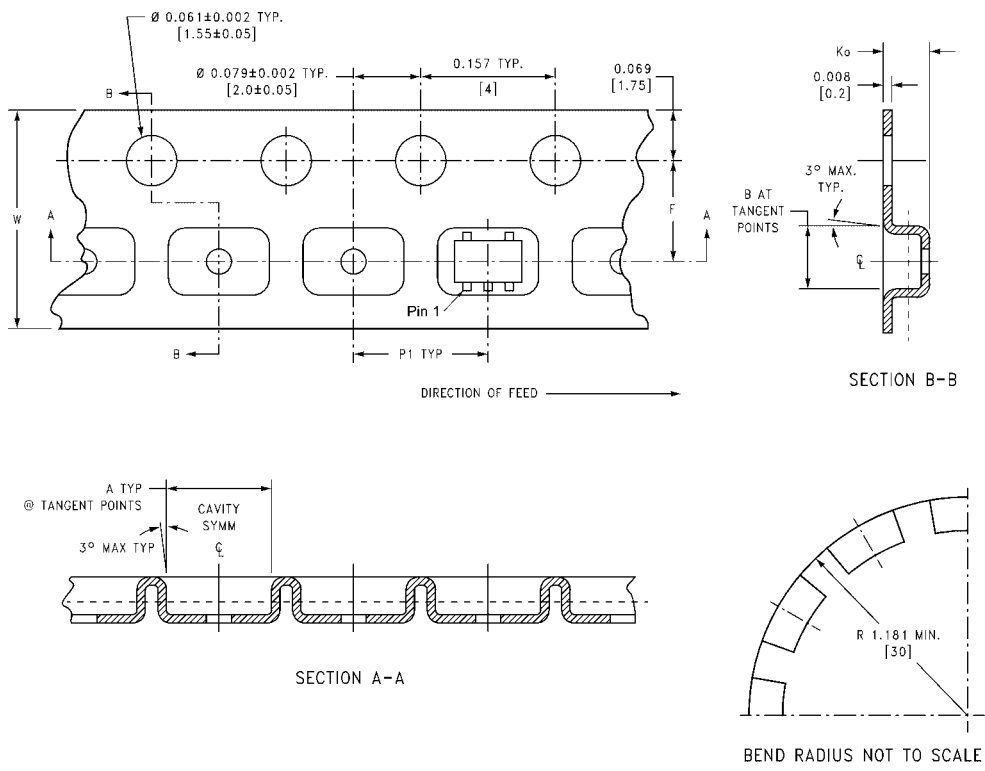

Package	Tape Size	Dim A	Dim B	Dim F	Dim K_0	Dim P1	Dim W
SC70-5	8 mm	0.093 (2.35)	0.096 (2.45)	0.138±0.004 (3.5±0.10)	0.053±0.004 (1.35±0.10)	0.157 (4)	0.315±0.004 (8±0.1)
SOT23-5	8 mm	0.130 (3.3)	0.130 (3.3)	0.138±0.002 (3.5±0.05)	0.055±0.004 (1.4±0.11)	0.157 (4)	0.315±0.012 (8±0.3)

Tape and Reel Specification (Continued)

Tape Format for MicroPak

Package Designator	Tape Section	Number Cavities	Cavity Status	Cover Tape Status
P6X	Leader (Start End)	125 (typ)	Empty	Sealed
	Carrier	5000	Filled	Sealed
	Trailer (Hub End)	75 (typ)	Empty	Sealed

Tape Dimension millimeters

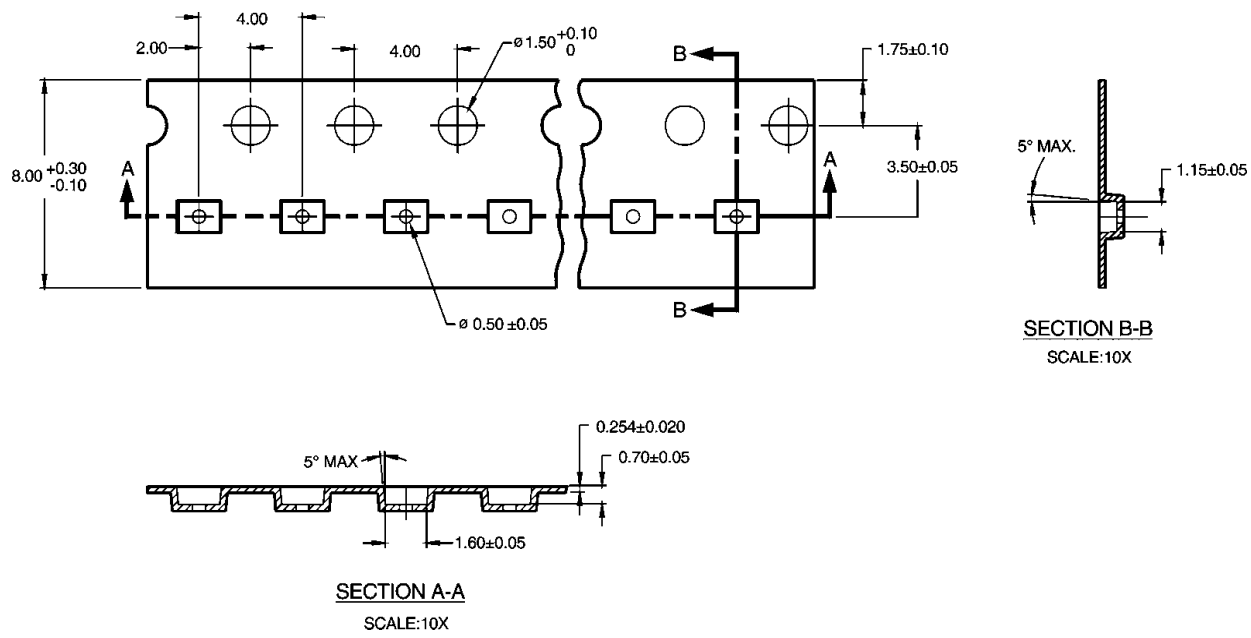

Tape and Reel Specification (Continued)

Reel Dimension for MicroPak inches (millimeters)

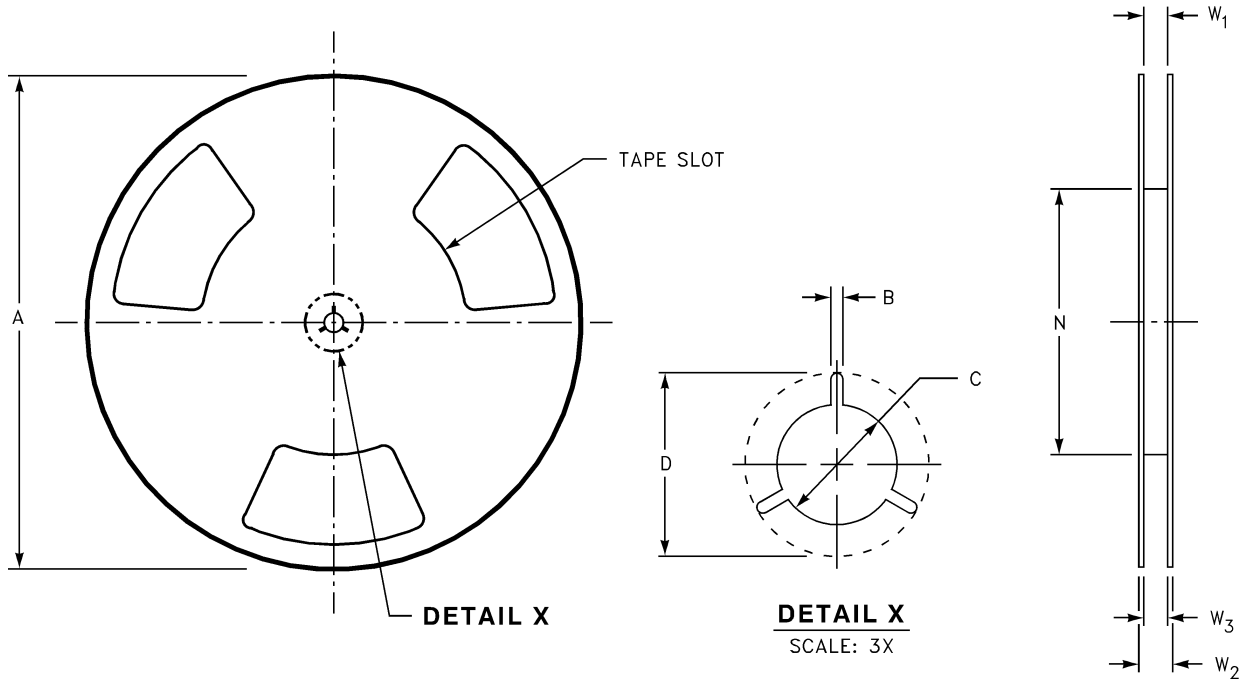

Tape Size	A	B	C	D	N	W1	W2	W3
8mm	7.0 (177.8)	0.059 (1.50)	0.512 (13.00)	0.795 (20.20)	2.165 (55.00)	0.331 + 0.059/-0.000 (8.40 + 1.50/-0.00)	0.567 (14.40)	W1 + 0.078/-0.039 (W1 + 2.00/-1.00)

Physical Dimensions millimeters unless otherwise noted

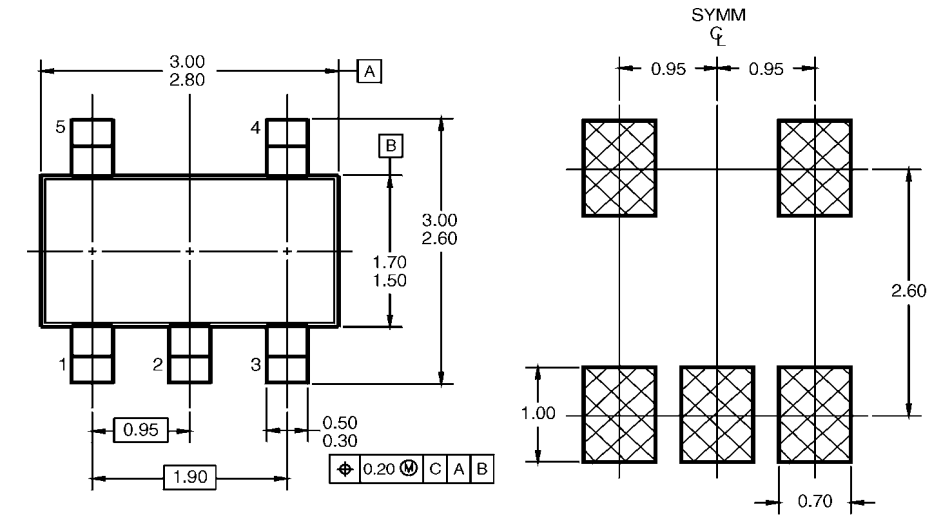

LAND PATTERN RECOMMENDATION

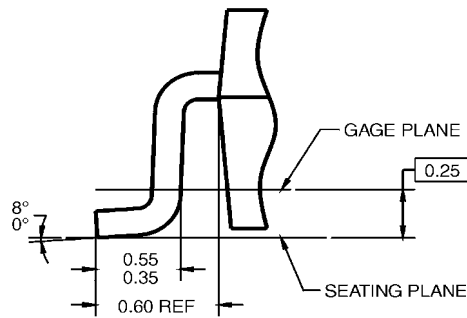
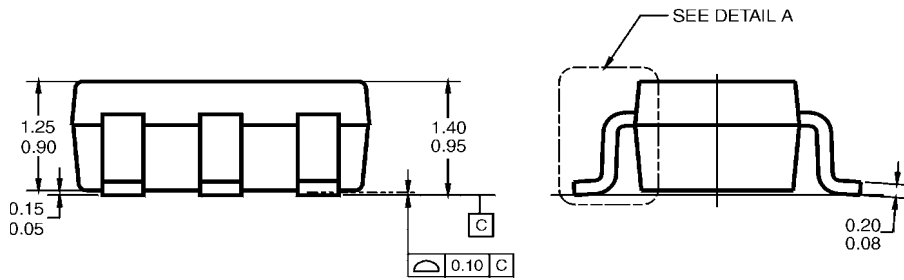

DETAIL A

- NOTES: UNLESS OTHERWISE SPECIFIED
 A) THIS PACKAGE CONFORMS TO JEDEC MO-178, ISSUE B, VARIATION AA, DATED JANUARY 1999.
 B) ALL DIMENSIONS ARE IN MILLIMETERS.

MA05BRevC

**5-Lead SOT23, JEDEC MO-178, 1.6mm
 Package Number MA05B**

Physical Dimensions millimeters unless otherwise noted (Continued)

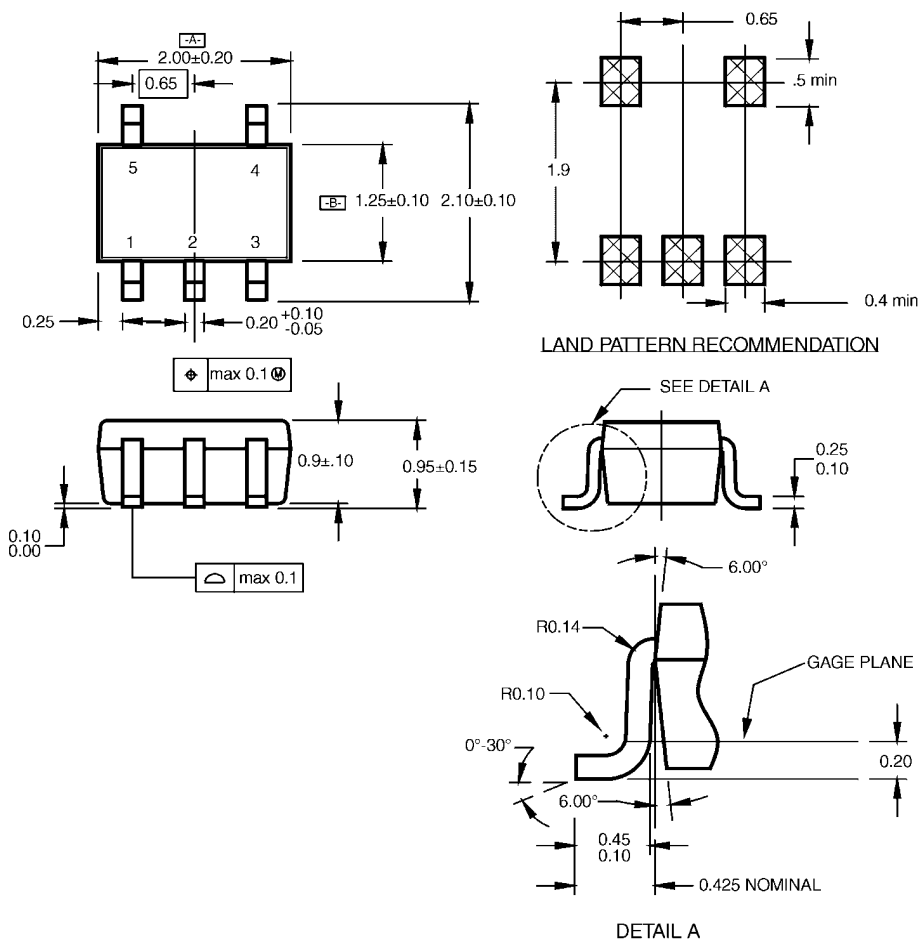

NOTES:

- A. CONFORMS TO EIAJ REGISTERED OUTLINE DRAWING SC88A.
- B. DIMENSIONS DO NOT INCLUDE BURRS OR MOLD FLASH.
- C. DIMENSIONS ARE IN MILLIMETERS.

MAA05ARevC

**5-Lead SC70, EIAJ SC-88a, 1.25mm Wide
Package Number MAA05A**

FAIRCHILD SEMICONDUCTOR TRADEMARKS

The following are registered and unregistered trademarks Fairchild Semiconductor owns or is authorized to use and is not intended to be an exhaustive list of all such trademarks.

ACEx™	FACT Quiet Series™	OCX™	SILENT SWITCHER®	UniFET™
ActiveArray™	GlobalOptoisolator™	OCXPro™	SMART START™	UltraFET®
Bottomless™	GTO™	OPTOLOGIC®	SPM™	VCX™
Build it Now™	HiSeC™	OPTOPLANAR™	Stealth™	Wire™
CoolFET™	I ² C™	PACMAN™	SuperFET™	
CROSSVOLT™	i-Lo™	POP™	SuperSOT™-3	
DOME™	ImpliedDisconnect™	Power247™	SuperSOT™-6	
EcoSPARK™	IntelliMAX™	PowerEdge™	SuperSOT™-8	
E ² CMOS™	ISOPLANAR™	PowerSaver™	SyncFET™	
EnSigna™	LittleFET™	PowerTrench®	TCM™	
FACT®	MICROCOUPLER™	QFET®	TinyBoost™	
FAST®	MicroFET™	QS™	TinyBuck™	
FASTr™	MicroPak™	QT Optoelectronics™	TinyPWM™	
FPS™	MICROWIRE™	Quiet Series™	TinyPower™	
FRFET™	MSX™	RapidConfigure™	TinyLogic®	
	MSXPro™	RapidConnect™	TINYOPTO™	
Across the board. Around the world.™		µSerDes™	TruTranslation™	
The Power Franchise®		ScalarPump™	UHC®	
Programmable Active Droop™				

DISCLAIMER

FAIRCHILD SEMICONDUCTOR RESERVES THE RIGHT TO MAKE CHANGES WITHOUT FURTHER NOTICE TO ANY PRODUCTS HEREIN TO IMPROVE RELIABILITY, FUNCTION, OR DESIGN. FAIRCHILD DOES NOT ASSUME ANY LIABILITY ARISING OUT OF THE APPLICATION OR USE OF ANY PRODUCT OR CIRCUIT DESCRIBED HEREIN; NEITHER DOES IT CONVEY ANY LICENSE UNDER ITS PATENT RIGHTS, NOR THE RIGHTS OF OTHERS. THESE SPECIFICATIONS DO NOT EXPAND THE TERMS OF FAIRCHILD'S WORLDWIDE TERMS AND CONDITIONS, SPECIFICALLY THE WARRANTY THEREIN, WHICH COVERS THESE PRODUCTS.

LIFE SUPPORT POLICY

FAIRCHILD'S PRODUCTS ARE NOT AUTHORIZED FOR USE AS CRITICAL COMPONENTS IN LIFE SUPPORT DEVICES OR SYSTEMS WITHOUT THE EXPRESS WRITTEN APPROVAL OF FAIRCHILD SEMICONDUCTOR CORPORATION.

As used herein:

- Life support devices or systems are devices or systems which, (a) are intended for surgical implant into the body, or (b) support or sustain life, or (c) whose failure to perform when properly used in accordance with instructions for use provided in the labeling, can be reasonably expected to result in significant injury to the user.
- A critical component is any component of a life support device or system whose failure to perform can be reasonably expected to cause the failure of the life support device or system, or to affect its safety or effectiveness.

PRODUCT STATUS DEFINITIONS

Definition of Terms

Datasheet Identification	Product Status	Definition
Advance Information	Formative or In Design	This datasheet contains the design specifications for product development. Specifications may change in any manner without notice.
Preliminary	First Production	This datasheet contains preliminary data, and supplementary data will be published at a later date. Fairchild Semiconductor reserves the right to make changes at any time without notice to improve design.
No Identification Needed	Full Production	This datasheet contains final specifications. Fairchild Semiconductor reserves the right to make changes at any time without notice to improve design.
Obsolete	Not In Production	This datasheet contains specifications on a product that has been discontinued by Fairchild semiconductor. The datasheet is printed for reference information only.

Rev. I21