

SMD Efficient Fast Recovery Rectifier

CEFC301-G Thru CEFC305-G (RoHS Device)

Reverse Voltage: 50 ~ 600 Volts

Forward Current: 3.0 Amp

Features:

- Ideal for surface mount applications
- Easy pick and place
- Plastic package has Underwriters Lab. flammability classification 94V-0.
- Super fast recovery time for high efficient
- Built-in strain relief
- Low forward voltage drop

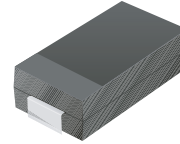

Mechanical Data:

- Case: JEDEC DO-214AB molded plastic
- Terminals: solderable per MIL-STD-750, method 2026
- Polarity: Color band denotes cathode end
- Approx. Weight: 0.063 gram

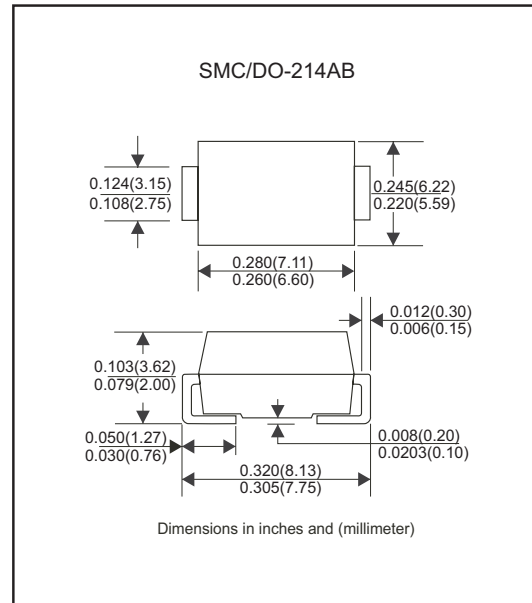

Maximum Ratings and Electrical Characteristics:

Parameter	Symbol	CEFC301-G	CEFC302-G	CEFC303-G	CEFC304-G	CEFC305-G	Unit
Max. Repetitive Peak Reverse Voltage	V_{RRM}	50	100	200	400	600	V
Max. DC Blocking Voltage	V_{DC}	50	100	200	400	600	V
Max. RMS Voltage	V_{RMS}	35	70	140	280	420	V
Peak Surge Forward Current 8.3ms single half sine-wave superimposed on rate load (JEDEC method)	I_{FSM}	75					A
Max. Average Forward Current	I_o	3.0					A
Max. Instantaneous Forward Voltage at 1.0A	V_F	0.875			1.1	1.25	V
Reverse recovery time	T_{rr}	25			35	50	nS
Max. DC Reverse Current at Rated DC Blocking Voltage $T_a=25^{\circ}C$ $T_a=100^{\circ}C$	I_R	5.0 200					μA
Max. Thermal Resistance (Note1)	$R_{\theta JL}$	13					$^{\circ}C/W$
Max. Operating Junction Temperature	T_j	-55 to +150					$^{\circ}C$
Storage Temperature	T_{STG}	-55 to +150					$^{\circ}C$

Note1: Thermal resistance from junction to lead mounted on PCB with 8.0mmx8.0mm² copper pad areas.

Rating and Characteristic Curves (CEFC301-G thru CEFC305-G)

Fig. 1 - Reverse Characteristics

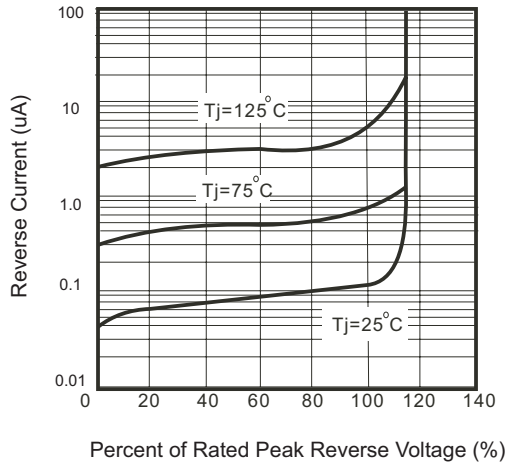

Fig. 2 - Forward Characteristics

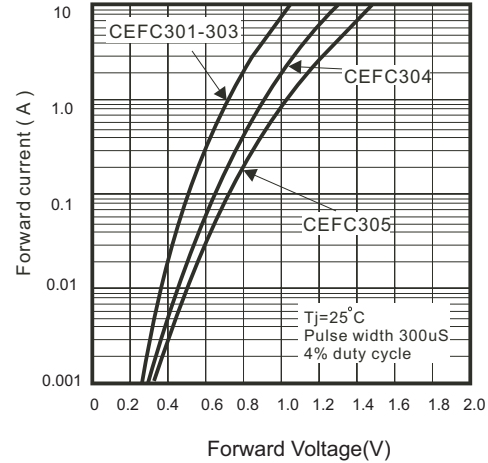

Fig. 3 - Junction Capacitance

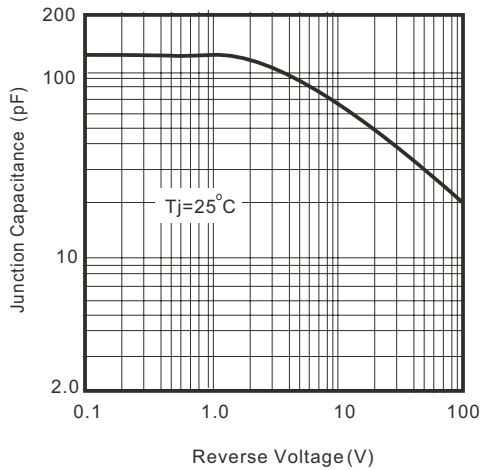

Fig. 4 - Non Repetitive Forward Surge Current

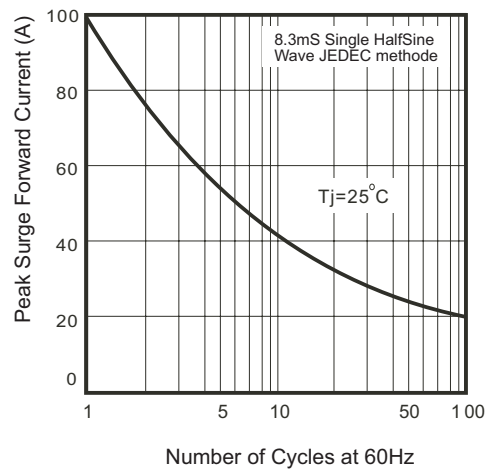

Fig. 5 - Test Circuit Diagram and Reverse Recovery Time Characteristics

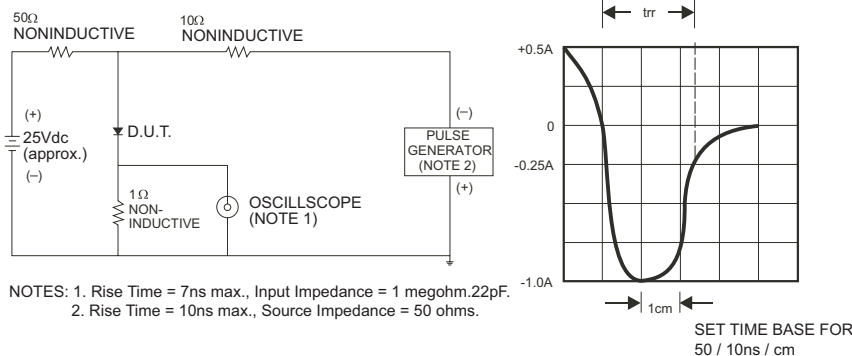

Fig. 6 - Current Derating Curve

