

D1FK70**700V 0.8A****特長**

- 小型SMD
- 高耐圧
- 低ノイズ
- $V_{RM} = 700V$

Feature

- Small SMD
- High Voltage
- Low Noise
- $V_{RM} = 700V$

用途

- スイッチング電源
- DC/DCコンバータ
- フライホイール
- 家電、OA、照明
- 通信、FA

Main Use

- Switching Regulator
- DC/DC Converter
- Fly Wheel
- Home Appliance, Office Automation, Lighting
- Communication, Factory Automation

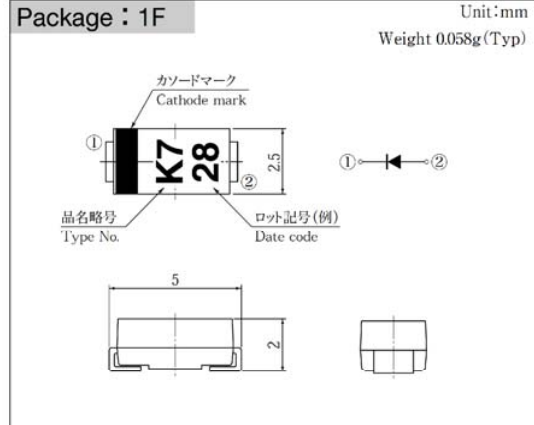
■外観図 OUTLINE

外形図については新電元Webサイト又は〈半導体製品一覧表〉をご参照下さい。捺印表示については捺印仕様をご確認下さい。
For details of the outline dimensions, refer to our web site or Semiconductor Short Form Catalog. As for the marking, refer to the specification "Marking, Terminal Connection".

■定格表 RATINGS**●絶対最大定格 Absolute Maximum Ratings (指定のない場合 $T_I = 25^\circ C$)**

項目 Item	記号 Symbol	条件 Conditions	品名 Type No.	D1FK70	単位 Unit
保存温度 Storage Temperature	T_{stg}			-55~150	$^\circ C$
接合部温度 Operation Junction Temperature	T_j			150	$^\circ C$
せん頭逆電圧 Maximum Reverse Voltage	V_{RM}			700	V
出力電流 Average Rectified Forward Current	I_O	50Hz正弦波, 抵抗負荷 50Hz sine wave, Resistance load	$T_a = 32^\circ C$ アルミ基板実装 On alumina substrate $T_a = 33^\circ C$ プリント基板実装 On glass-epoxy substrate	0.8 0.6	A
せん頭サージ順電流 Peak Surge Forward Current	I_{FSM}	50Hz正弦波, 非繰り返し1サイクルせん頭値, $T_j = 25^\circ C$ 50Hz sine wave, Non-repetitive 1 cycle peak value, $T_j = 25^\circ C$		25	A

●電氣的・熱的特性 Electrical Characteristics (指定のない場合 $T_I = 25^\circ C$)

順電圧 Forward Voltage	V_F	$I_F = 0.8A$, パルス測定 Pulse measurement		MAX 1.3	V
逆電流 Reverse Current	I_R	$V_R = V_{RM}$, パルス測定 Pulse measurement		MAX 10	μA
逆回復時間 Reverse Recovery Time	t_{rr}	$I_F = 0.5A, I_R = 1A$		MAX 400	ns
接合容量 Junction Capacitance	C_j	$f = 1MHz, V_R = 10V$		TYP 7	pF
熱抵抗 Thermal Resistance	θ_{jl}	接合部・リード間 Junction to lead		MAX 23	$^\circ C/W$
	θ_{ja}	接合部・周囲間 Junction to ambient	アルミ基板実装 On alumina substrate プリント基板実装 On glass-epoxy substrate	MAX 108 MAX 157	

■特性図 CHARACTERISTIC DIAGRAMS

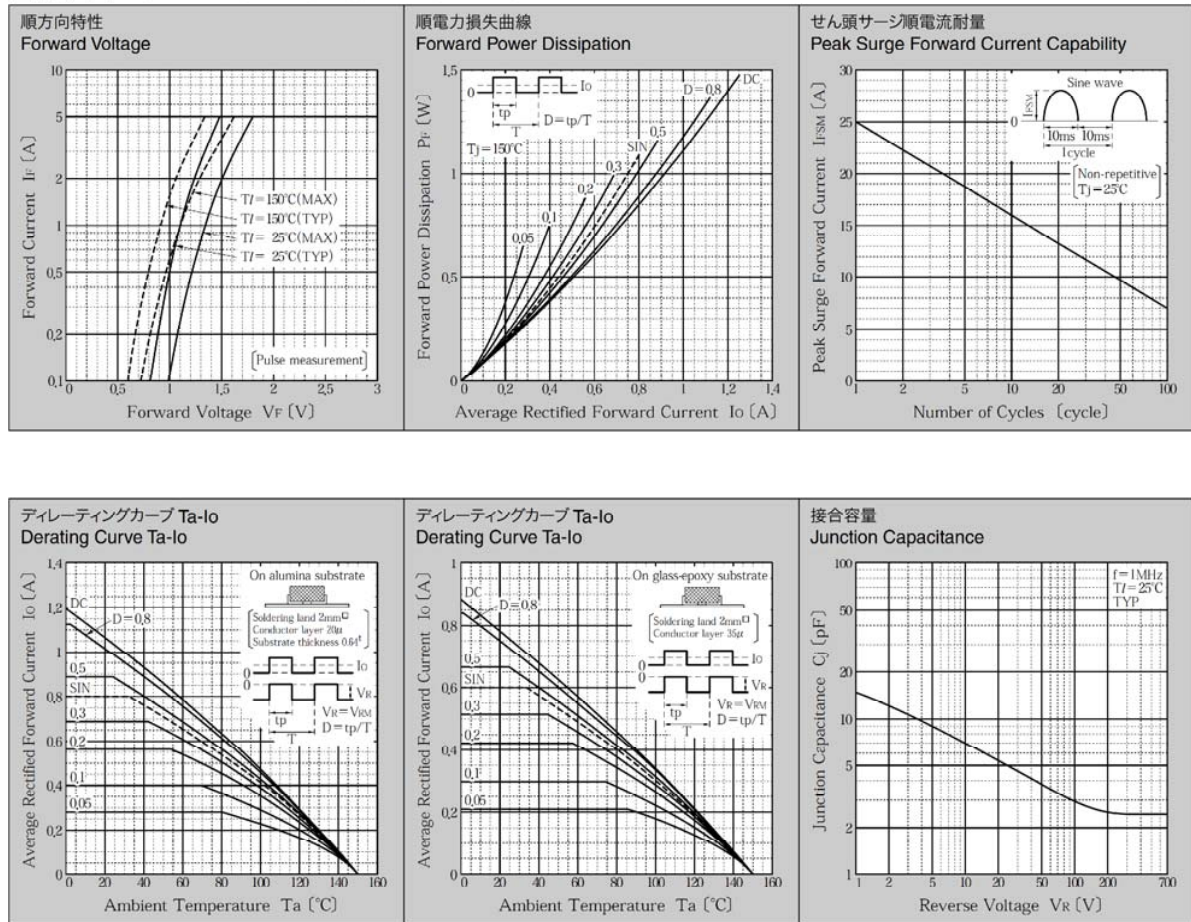

* Sine waveは50Hzで測定しています。
 * 50Hz sine wave is used for measurements.
 * 半導体製品の特性は一般的にバラツキを持っており、Typicalは統計的な実力を表しています。
 * Semiconductor products generally have characteristic variation. Typical is a statistical average of the device's ability.