



SMP30-xxx Series

TRISIL™

FEATURES

- BIDIRECTIONAL CROWBAR PROTECTION.
- VOLTAGE RANGE: FROM 62 V TO 270 V.
- HOLDING CURRENT :
 $I_H = 150 \text{ mA min.}$
- REPETITIVE PEAK PULSE CURRENT :
 $I_{PP} = 30 \text{ A, } 10/1000 \mu\text{s.}$
- JEDEC REGISTERED PACKAGE OUTLINE

DESCRIPTION

The SMP30-xxx series has been designed to protect telecommunication equipments against lightning surges and overvoltages induced by AC power lines.

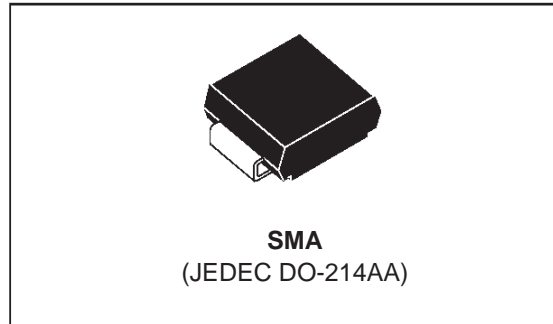

SCHEMATIC DIAGRAM

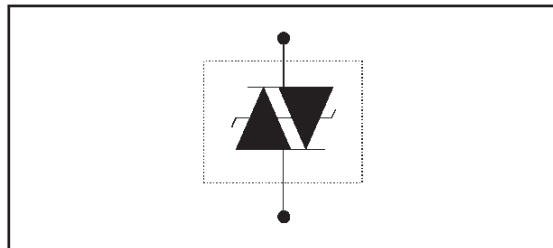

COMPLIES WITH THE FOLLOWING STANDARDS:	Peak Surge Voltage (V)	Voltage Waveform (μs)	Current Waveform (μs)	Admissible I_{pp} (A)	Necessary Resistor (Ω)
(CCITT) ITU-K20	1000	10/700	5/310	25	-
(CCITT) ITU-K17	1500	10/700	5/310	38	-
VDE0433	2000	10/700	5/310	40	10
VDE0878	2000	1.2/50	1/20	50	-
IEC-1000-4-5	level 2 level 3	10/700 1.2/50	5/310 8/20	25 50	- -
FCC Part 68, lightning surge type A	1500 800	10/160 10/560	10/160 10/560	65 50	15.5 8.0
FCC Part 68, lightning surge type B	1000	9/720	5/320	25	-
BELLCORE TR-NWT-001089 First level	2500 1000	2/10 10/1000	2/10 10/1000	125 30	15.0 23.3
BELLCORE TR-NWT-001089 Second level	5000	2/10	2/10	125	15.0
BELLCORE TR-NWT-001089 Intra building lightning	1500	2/10	2/10	100	-
CNET I31-24	1000	0.5/700	0.8/310	25	-

SMP30-xxx Series

ABSOLUTE MAXIMUM RATINGS ($T_{amb} = 25^{\circ}\text{C}$)

Symbol	Parameter	Value	Unit
P	Power dissipation on infinite heatsink	$T_{amb} = 50^{\circ}\text{C}$ 3	W
I_{PP}	Peak pulse current	10/1000 μs 8/20 μs 30 60	A
I_{TSM}	Non repetitive surge peak on-state current	$t_p = 20 \text{ ms}$ 15	A
I^2t	I^2t value for fusing	$t_p = 20 \text{ ms}$ 1	A^2s
dV/dt	Critical rate of rise of off-state voltage	V_{RM} 5	$\text{kV}/\mu\text{s}$
T_{stg} T_j	Storage temperature range Maximum junction temperature	- 55 to + 150 150	$^{\circ}\text{C}$ $^{\circ}\text{C}$
T_L	Maximum lead temperature for soldering during 10s at 5mm for case	260	$^{\circ}\text{C}$

THERMAL RESISTANCES

Symbol	Parameter	Value	Unit
$R_{th(j-l)}$	Junction to leads	30	$^{\circ}\text{C}/\text{W}$
$R_{th(j-a)}$	Junction to ambient on printed circuit with standard footprint dimension	120	$^{\circ}\text{C}/\text{W}$

ELECTRICAL CHARACTERISTICS

($T_{amb} = 25^{\circ}\text{C}$)

Symbol	Parameter
V_{RM}	Stand-off voltage
I_{RM}	Leakage current at stand-off voltage
V_R	Continuous Reverse voltage
V_{BR}	Breakdown voltage
V_{BO}	Breakover voltage
I_H	Holding current
I_{BO}	Breakover current
I_{PP}	Peak pulse current
C	Capacitance

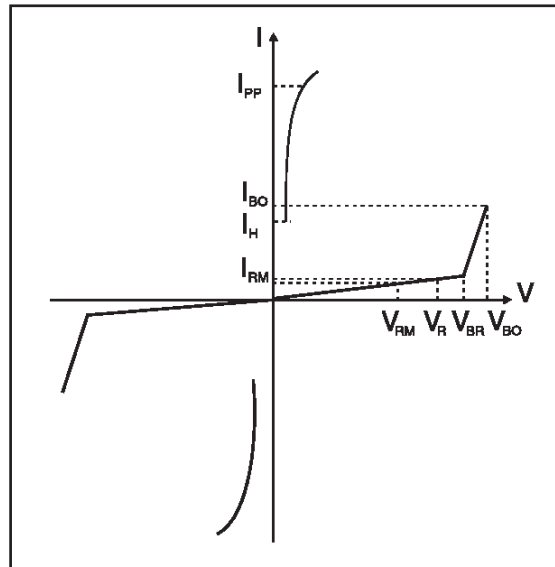

Type	Marking	I_{RM} @ V_{RM}		I_R @ V_R		V_{BO} @ I_{BO}		I_H min note 3	C	
		max		max note 1		max note 2			typ note 4	typ note 5
		μA	V	μA	V	V	mA			
SMP30-62	QAA	2	56	50	62	82	800	150	50	20
SMP30-68	QAB	2	61	50	68	90	800	150	50	20
SMP30-100	QAC	2	90	50	100	133	800	150	40	16
SMP30-120	QAD	2	108	50	120	160	800	150	40	16
SMP30-130	QAE	2	117	50	130	173	800	150	35	14
SMP30-180	QAF	2	162	50	180	240	800	150	35	14
SMP30-200	QAG	2	180	50	200	267	800	150	30	12
SMP30-220	QAH	2	198	50	220	293	800	150	30	12
SMP30-240	QAI	2	216	50	240	320	800	150	30	12
SMP30-270	QAJ	2	243	50	270	360	800	150	30	12

- Note 1: I_R measured at V_R guarantee $V_{BRmin} | V_R$
- Note 2: Measured at 50 Hz (1 cycle) - See test circuit 1.
- Note 3: See test circuit 2.
- Note 4: $V_R = 1V, F = 1MHz$.
- Note 5: $V_R = 50V, F = 1MHz$

TEST CIRCUIT 1 FOR I_{BO} and V_{BO} parameters :

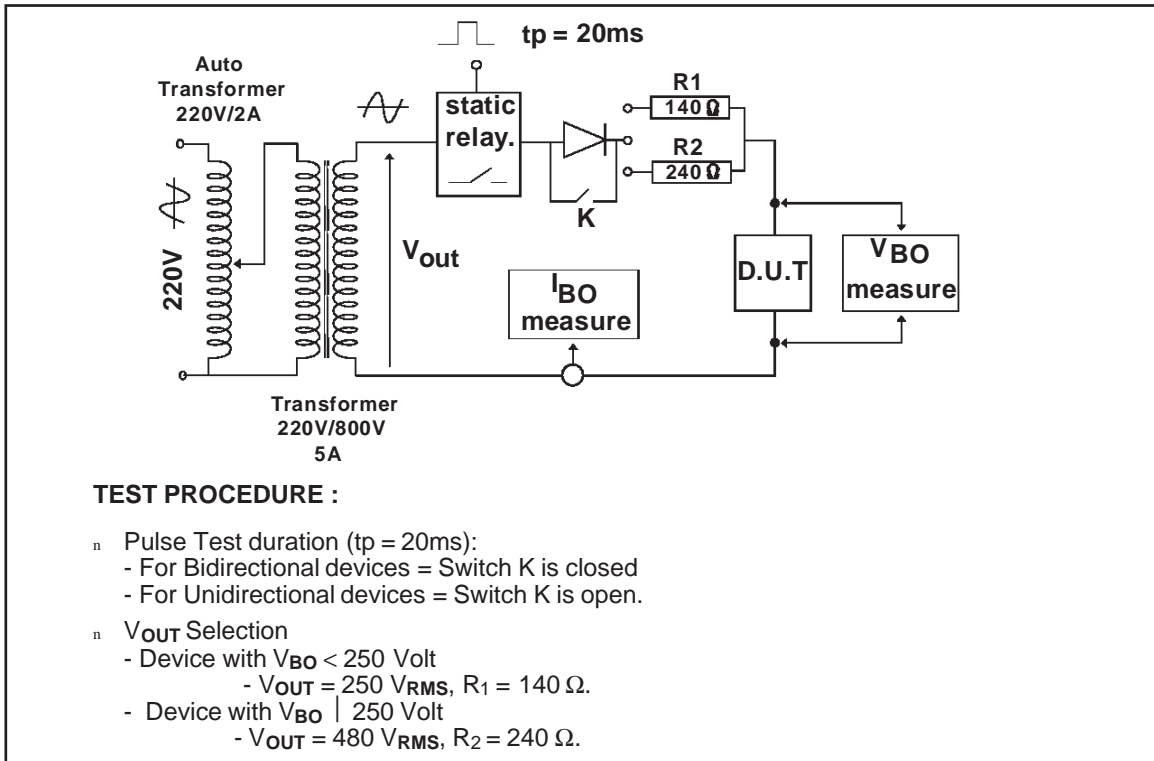

TEST CIRCUIT 2 for I_H parameter.

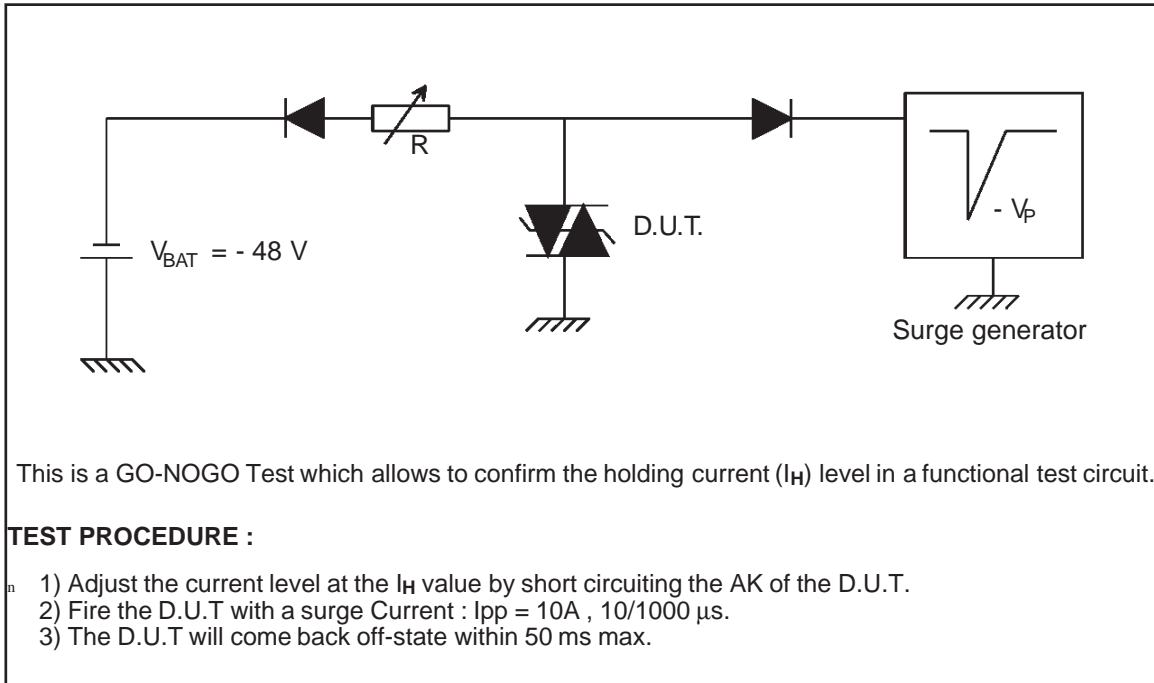

Fig. 1: Non repetitive surge peak on-state current versus overload duration (T_j initial=25°C).

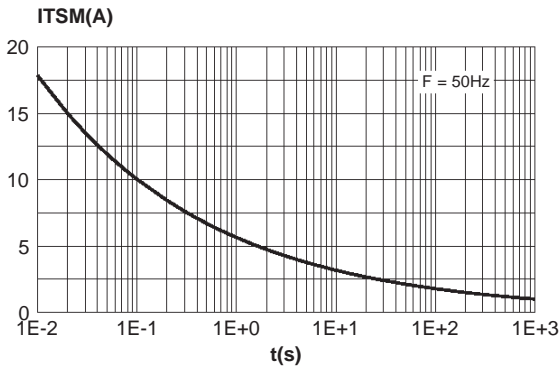

Fig. 2: Relative variation of holding current versus junction temperature.

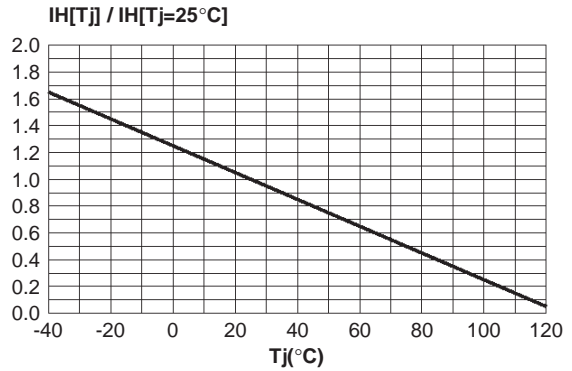

Fig. 3: Relative variation of junction capacitance versus reverse applied voltage (typical values)

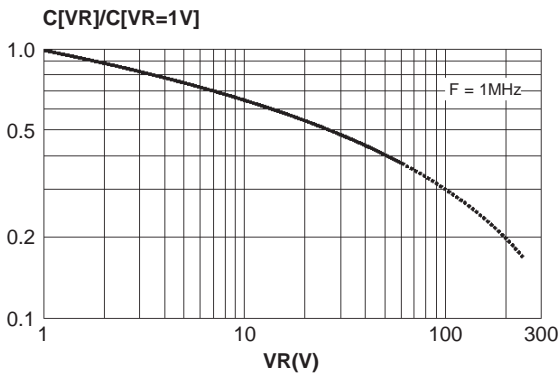

Fig. 4: On-state voltage versus on-state current (typical values).

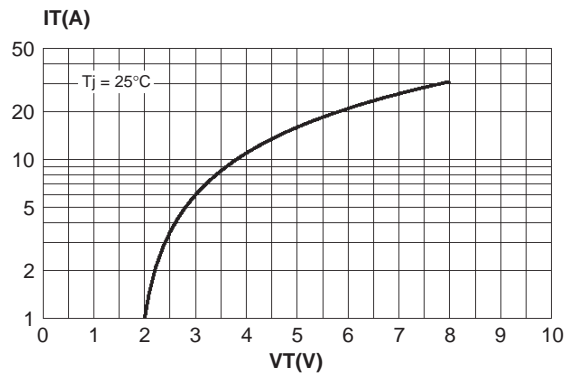

Fig. 5: Variation of thermal impedance junction to ambient versus pulse duration.

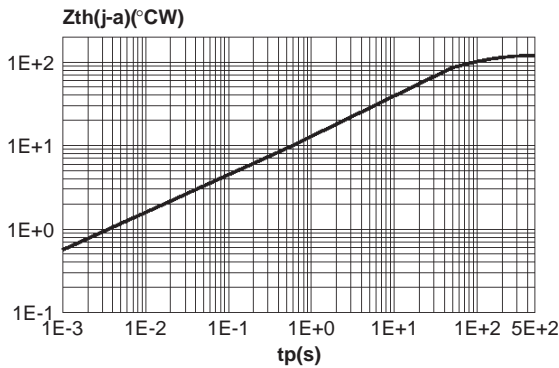
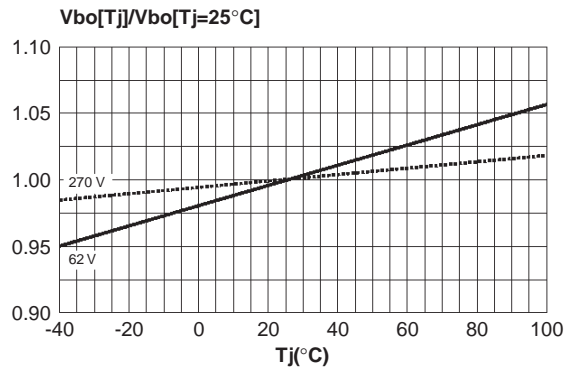
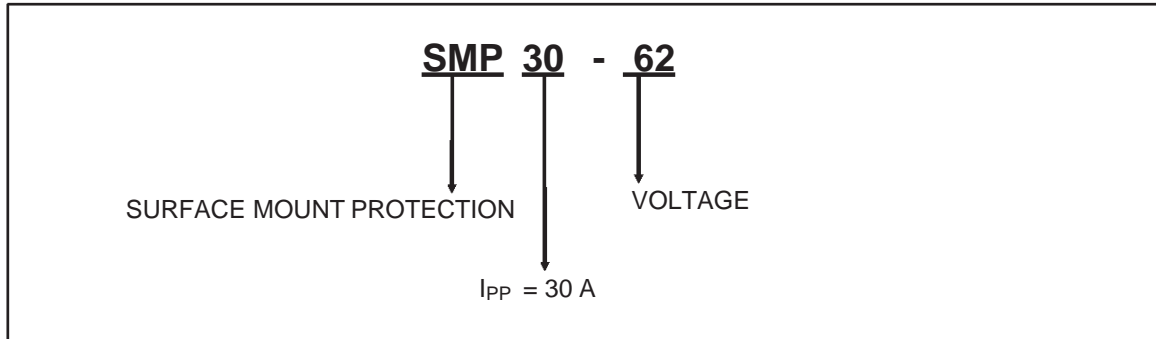

Fig. 6: Relative variation of V_{BO} voltage versus junction temperature.



SMP30-xxx Series

ORDER CODE



MARKING : Logo, Date Code, Part Number.

PACKAGE MECHANICAL DATA SMA (JEDEC DO-214AA)

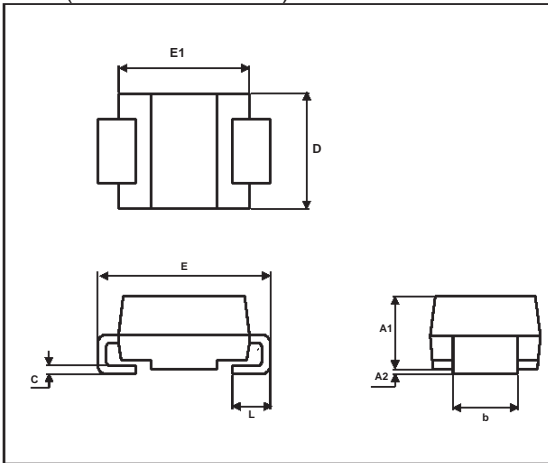

REF.	DIMENSIONS			
	Millimeters		Inches	
	Min.	Max.	Min.	Max.
A1	1.90	2.70	0.075	0.106
A2	0.05	0.20	0.002	0.008
b	1.25	1.65	0.049	0.065
c	0.15	0.41	0.006	0.016
E	4.80	5.60	0.189	0.220
E1	3.95	4.60	0.156	0.181
D	2.25	2.95	0.089	0.116
L	0.75	1.60	0.030	0.063

FOOT PRINT (in millimeters)

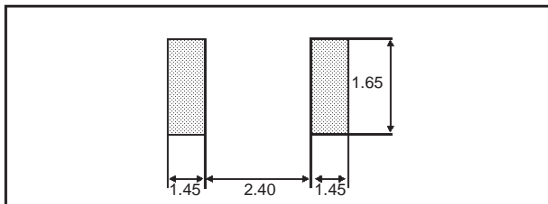

Weight: 0.06 g

Packaging : Tape and reel.

Information furnished is believed to be accurate and reliable. However, STMicroelectronics assumes no responsibility for the consequences of use of such information nor for any infringement of patents or other rights of third parties which may result from its use. No license is granted by implication or otherwise under any patent or patent rights of STMicroelectronics. Specifications mentioned in this publication are subject to change without notice. This publication supersedes and replaces all information previously supplied. STMicroelectronics products are not authorized for use as critical components in life support devices or systems without express written approval of STMicroelectronics.

The ST logo is a registered trademark of STMicroelectronics

© 2000 STMicroelectronics - Printed in Italy - All rights reserved.

STMicroelectronics GROUP OF COMPANIES

Australia - Brazil - China - Finland - France - Germany - Hong Kong - India - Italy - Japan - Malaysia
Malta - Morocco - Singapore - Spain - Sweden - Switzerland - United Kingdom - U.S.A.

<http://www.st.com>