

9097247 TOSHIBA. ELECTRONIC

02E 17491 D

TA7666P
TA7667P

T-52-13-07

**5 STEP LOGARITHMIC
DUAL LED DRIVER**

Both of the TA7666P and the TA7667P consist of two inverting amplifiers, ten comparators and a reference voltage network.

Turn-on level intervals are 5dB, 5dB, 3dB, 3dB, in TA7666P, and are 2dB, 2dB, 2dB, 2dB in TA7667P.

It is suitable for stereo radio cassette applications because of dual type.

- . Suitable for Stereo LED Driver
- . Wide Supply Voltage Range : $V_{CC}=6\sim 12V$
- . Low Quiescent Current : $I_{CCQ}=4mA(Typ.)$ at $V_{CC}=9V$
- . Variable Voltage Gain Because of Inverting Amplifier.
- . Easy Arrangement for Dual 10 LED's Driver by Series Connection of TA7666P and TA7667P

Unit in mm

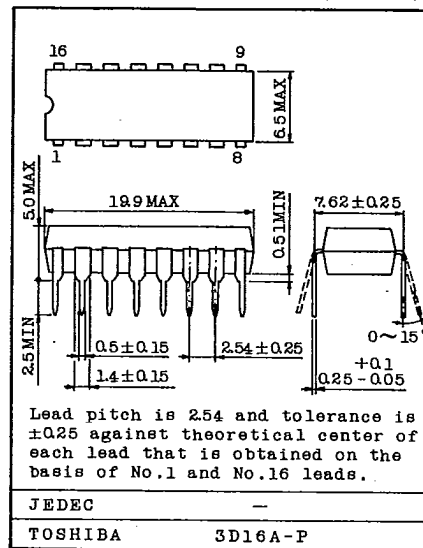
MAXIMUM RATINGS ($T_a=25^{\circ}C$)

CHARACTERISTIC	SYMBOL	RATING	UNIT
Supply Voltage	V_{CC}	14	V
Output Current	I_O	30	mA
LED Drive Terminal Voltage (Note 1)	V_L	15	V
Power Dissipation (Note 2)	P_D	750	mW
Operating Temperature	T_{opr}	-30 ~ 75	$^{\circ}C$
Storage Temperature	T_{stg}	-55 ~ 150	$^{\circ}C$

Note 1. LED drive terminal voltage is maximum voltage at terminals from 3 to 7 and from 10 to 14.

2. Derated above $T_a=25^{\circ}C$ in the proportion of $6mW/^{\circ}C$.

TOSHIBA

9097247 TOSHIBA, ELECTRONIC

02E 17492 D

TA7666P
TA7667P

T-52-13-07

ELECTRICAL CHARACTERISTICS

(Unless otherwise specified, $V_{CC}=9V$, $f=1kHz$, $T_a=25^{\circ}C$)

CHARACTERISTIC	SYMBOL	TEST CIR-CUIT	TEST CONDITION	MIN.	TYP.	MAX.	UNIT
Quiescent Current	I_{CCQ}		$V_{IN}=0$	-	4	6	mA
Output Current	I_O		$V_{CE}=2V$	15	20	30	mA
Output Leak Current	$I_{O(OFF)}$		$V_{IN}=0$	-	-	50	μA
Voltage Gain	G_V		-	-	12.6	-	dB

TA7666P

Comparator Turn-On Thresholds	LD5	$G_V=12.6dB$	-1	0	1	dB
			189	212	238	mV _{rms}
	LD4		-4	-3	-2	dB
			134	150	168	mV _{rms}
	LD3		-7.5	-6	-4.5	dB
			89	106	126	mV _{rms}
	LD2		-13	-11	-9	dB
			47	60	75	mV _{rms}
	LD1		-19	-16	-13	dB
			24	34	47	mV _{rms}
1st Threshold Difference between R and L Channel	$\Delta LD1$		-1	0	1	dB

TA7667P

Comparator Turn-On Thresholds	LD5	$G_V=12.6dB$	-1	0	1	dB
			189	212	238	mV _{rms}
	LD4		-3	-2	-1	dB
			150	168	189	mV _{rms}
	LD3		-5	-4	-3	dB
			119	134	150	mV _{rms}
	LD2		-7	-6	-5	dB
			95	106	119	mV _{rms}
	LD1		-9	-8	-7	dB
			75	84	95	mV _{rms}
1st Threshold Difference between R and L Channel	$\Delta LD1$		-1	0	1	dB

AUDIO LINEAR IC

TA7666P
TA7667P

T-52-13-07

TEST CIRCUIT/BLOCK DIAGRAM

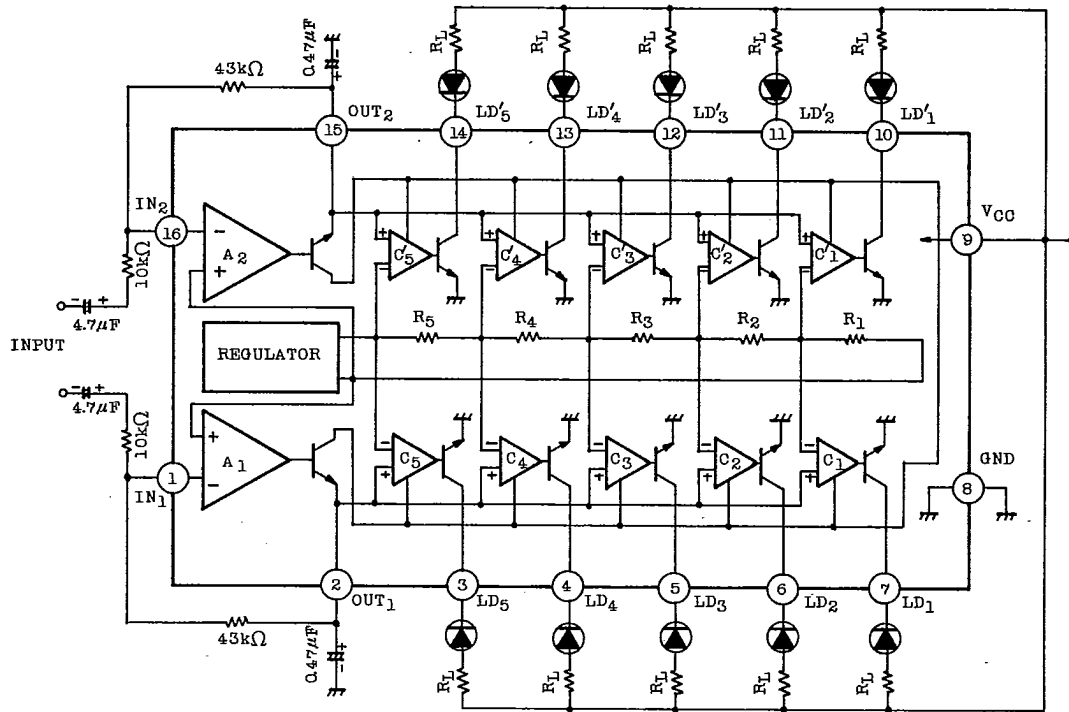

INTERNAL RESISTANCE VALUE

	TA7666P	TA7667P	UNIT
R1	1.36	3.66	kΩ
R2	1.08	0.948	kΩ
R3	1.89	1.19	kΩ
R4	1.78	1.50	kΩ
R5	2.50	1.89	kΩ

TOSHIBA

TA7666P
TA7667P

T-52-13-07

(1) SETUP OF TURNING-ON LEVEL

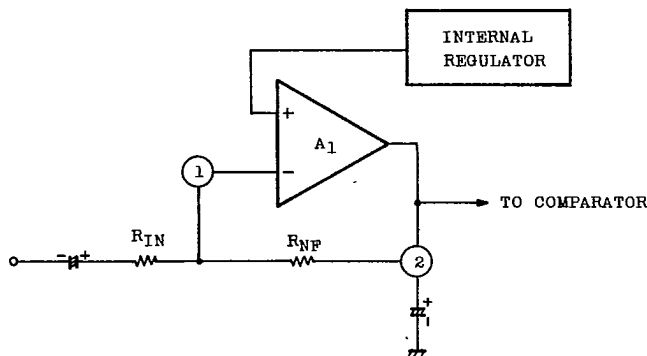

As voltage gain of inverting amplifier depends on signal source resistance R_g , output resistance of prestage amplifier should be smaller than $10 \times R_{IN}$.

(Output resistance $\leq 10 R_{IN}$)

It is better to change R_{NF} for voltage gain adjustment, As 5th LED turn-on input level is $911.6 \text{ mV}_{\text{rms}}$ at $G_v=0\text{dB}$, voltage gain of inverting amplifier is set by the following equation.

$$\text{Voltage Gain} = 20 \log \frac{911.6 \text{ (mV}_{\text{rms}})}{V_{IN}(\text{Input Voltage})} \text{ (dB)}$$

(Example) Case of 5th LED turn-on at $300 \text{ mV}_{\text{rms}}$ input level

$$\text{Voltage Gain} = \frac{911.6}{300} \div 3 \text{ (9.6dB)}$$

When R_{IN} is set up to be $10 \text{ k}\Omega$, R_{NF} becomes $30 \text{ k}\Omega$.

$$R_{NF} = 3 \times R_{IN} = 30 \text{ k}\Omega$$

Then each LED turn-on level is as follows.

IC	1st LED	2nd LED	3rd LED	4th LED	5th LED
TA7666P	48 -16dB	86 -11dB	152 -6dB	215 -3dB	$304 \text{ mV}_{\text{rms}}$ 0dB
TA7667P	121 -8dB	152 -6dB	192 -4dB	241 -2dB	$304 \text{ mV}_{\text{rms}}$ 0dB

TA7666P
TA7667P

T-52-13-07

(2) 5 LED×2 APPLICATION CIRCUIT (TA7666P)

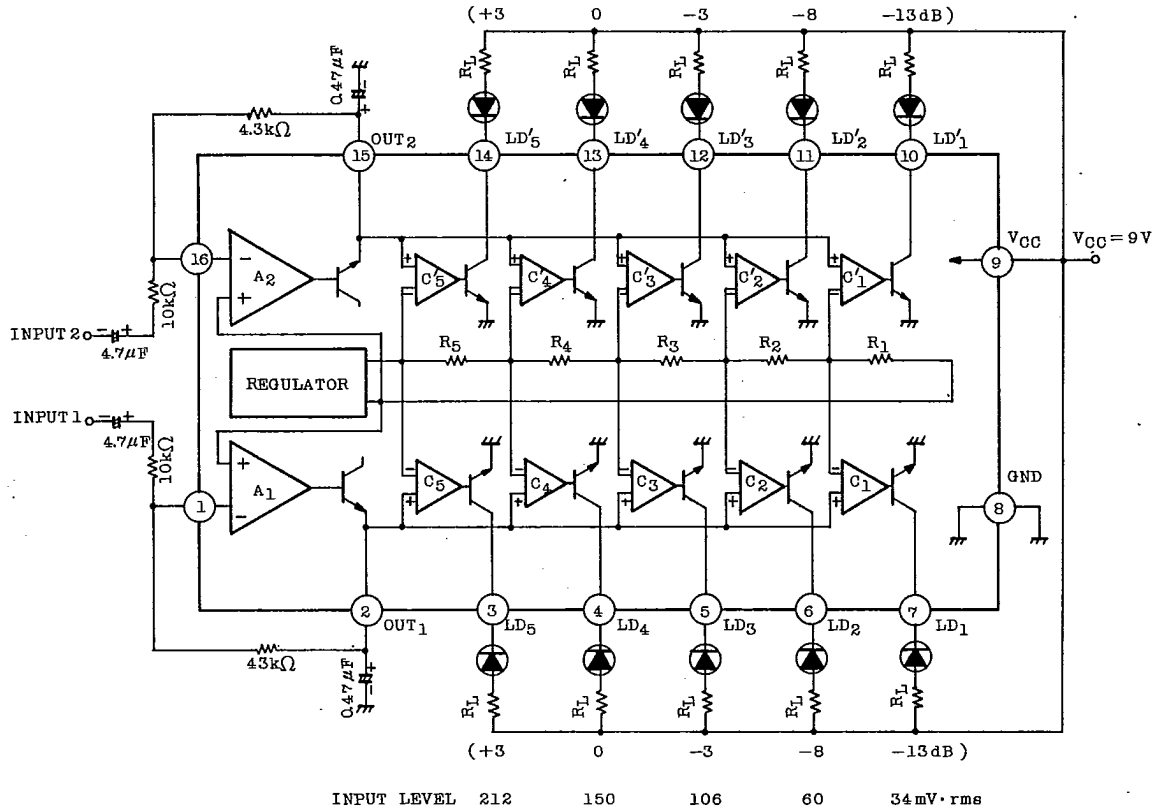

TA7666P
TA7667P

T-52-13-07

(3) 10 LED x 2 APPLICATION CIRCUIT (TA7666P+TA7667P)

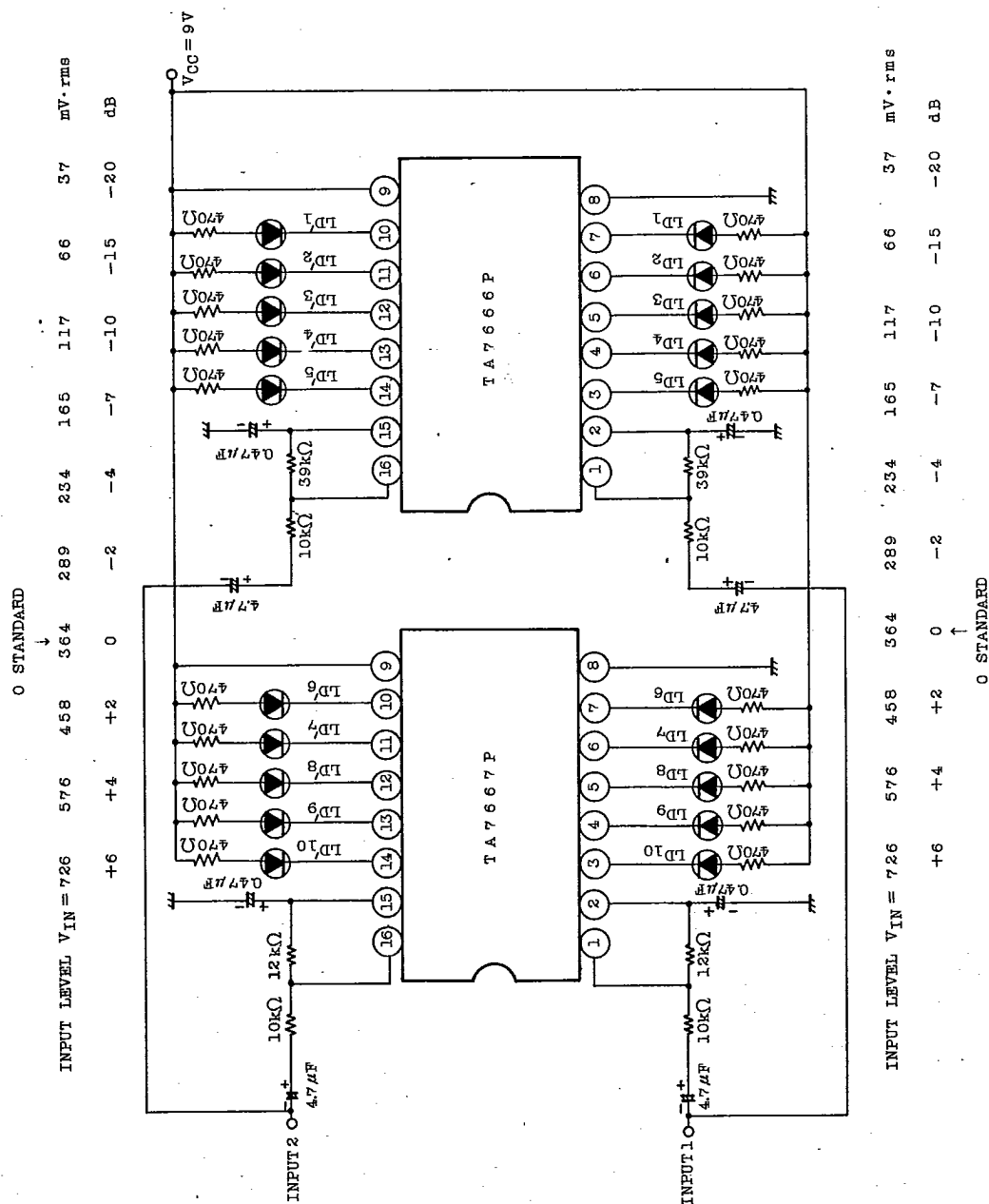

AUDIO LINEAR IC