



LA9235M

RF Head Amplifier for CD Player

Preliminary

Overview

The LA9235M is an IC for generating servo error signals and RF signals supporting CD player playback. Combined with a digital servo DSP, this IC can be used to configure a CD player using few components.

Functions and Features

- Generation of tracking error signal (Variable balance circuit)
- Generation of focus error signal
- Generation of RF signal (3T Compensation normal/N × speed supported switch)
- Generation of HFL signal (N × speed switching)
- Generation of TES signal (N × speed switching)
- Internal I/V conversion amplifier
- APC (auto laser power control) circuit

Package Dimensions

unit: mm

3073A-MFP30SD

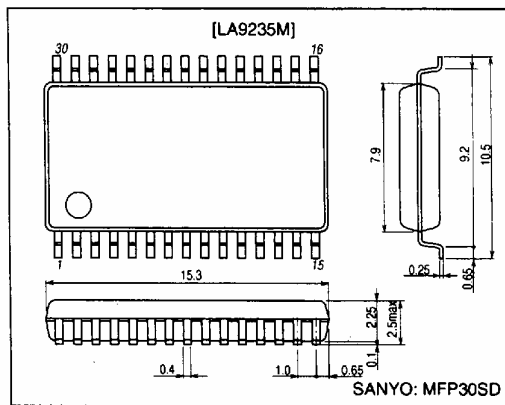

Specifications

Absolute Maximum Ratings at Ta = 25°C

Parameter	Symbol	Conditions	Ratings	Unit
Maximum supply voltage	V _{CC} max		7	V
Allowable power dissipation	P _d max		200	mW
Operating temperature	T _{opr}		-25 to +70	°C
Storage temperature	T _{stg}		-40 to +150	°C

Operating Conditions at Ta = 25°C

Parameter	Symbol	Conditions	Ratings	Unit
Operating supply voltage range	V _{CCop}		3.0 to 5.5	V

SANYO ELECTRONICS CO., LTD.
 1-1-1, HIRAKAWA-CHO, SUITEN-KU, OSAKA
 565-0871, JAPAN
 TEL: 06-6642-2111
 FAX: 06-6642-2112
 E-MAIL: SALES@SANYO-IC.COM
 WWW.SANYO-IC.COM

LA9235M

Electrical /Operating Characteristics at Ta = 25°C, V_{CC} (Pin 30) = 5 V, GND (Pin 9) = 0 V

Parameter	Symbol	Conditions	Ratings			Unit
			min	typ	max	
Current drain	I _{CC}	No signal	8.5	13.9	18.5	mA
Reference voltage	V _{REF}	Load current ±2 mA	2.2	2.5	2.8	V
RFGAIN1	RFG1	AGC on, input: 120 mVp-p 200 kHz	16	20	23	dB
RFGAIN2	RFG2	AGC on, input: 240 mVp-p 200 kHz	14	16.4	21	dB
RFAGCOFF	RFAOF	AGC off, input: 240 mVp-p 200 kHz	15.5	19.5	22.5	dB
FEGAIN	FEG	Input: 10 kHz	3.7	5.7	8.7	dB
FEOffset	FEOST	Input: V _{REF}	-150	0	150	mV
TEGAIN	TEG	Input: 10 kHz	20	23.3	27	dB
TEOffset	TEOST	Input: V _{REF}	-150	0	150	mV
TESGAIN1	TESG1	ODRV off, input: 10 kHz	20	24	29	dB
TESGAIN2	TESG2	ODRV on, input: 160 kHz	11	15	19	dB
APC1	APC1	LDS 180 mV, LDon	2.3	3	3.8	V
APC2	APC2	LDS 150 mV, LDon	0.5	1.25	2.0	V
APCoff	APCOF	LDS 150 mV, LDoFF	4	4.2		V
RFENV	RFEV	ODRV on, input: 200 mVp-p 200 kHz, AM 50% (20 kHz)	380	430	480	Vp-p
HFL	HFL	Input: 200 mVp-p 200 kHz, AM 50% (20 kHz)	18	20	22	kHz

Equivalent Circuit Block Diagram

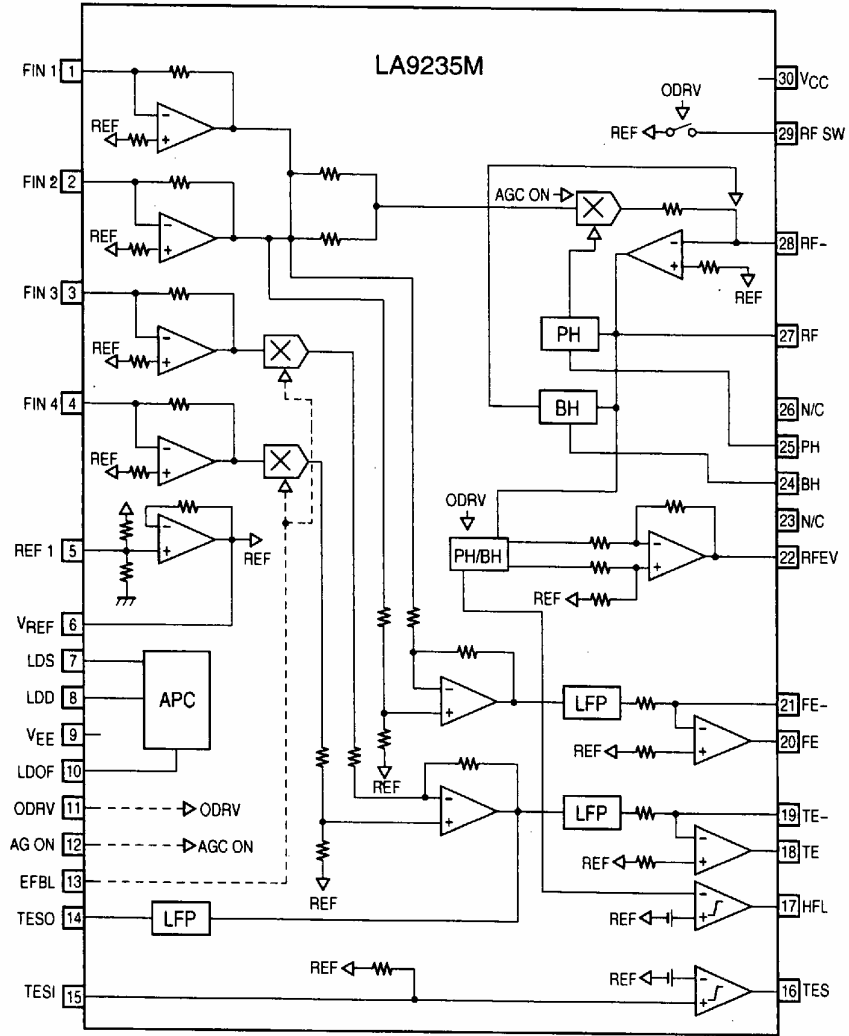

Test Circuit

