

**MOSFET**

**85A 450~500V**

PD10M441H PD10M440H  
P2H10M441H P2H10M440H

**PD10M441H/440H**

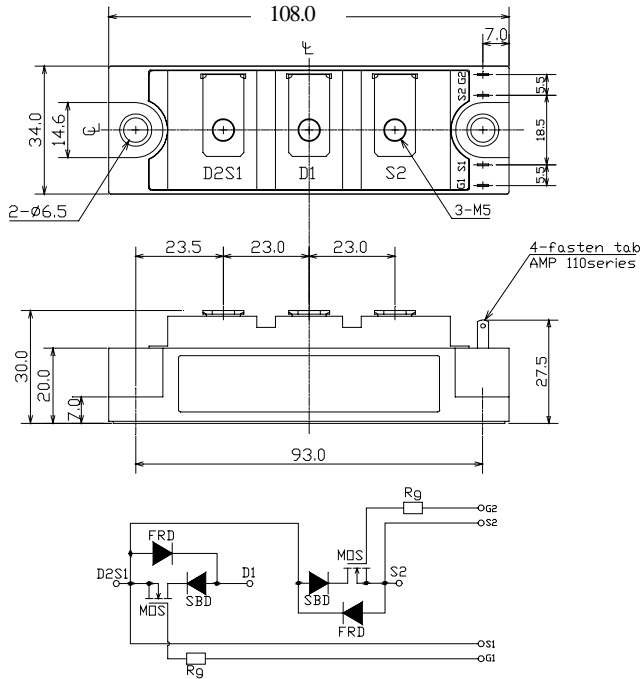

質量 Approximate Weight :220g

最大定格 Maximum Ratings

**P2H10M441H/440H**

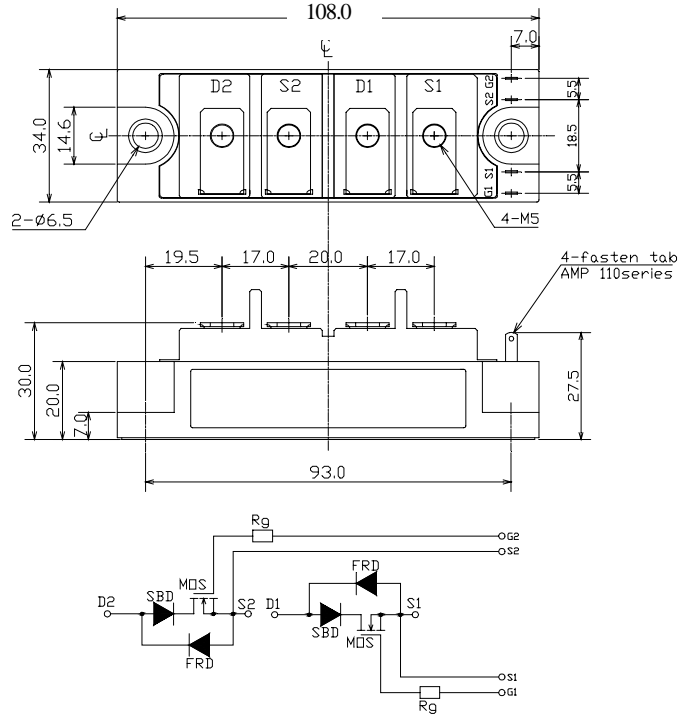

質量 Approximate Weight :220g

項目 Rating	記号 Symbol	耐圧・クラス Grade		単位 Unit
		PD10M441H/P2H10M441H	PD10M440H/P2H10M440H	
ドレイン・ソース間電圧 Drain-Source Voltage	$V_{DSS}$	450	500	V
		$V_{GS}=0V$		
ゲート・ソース間電圧 Gate-Source Voltage	$V_{GSS}$	± 20		V
ドレイン電流 (連続) Continuous Drain Current	$I_D$	85 ( $T_c=25$ )		A
Duty=50% D.C.		60 ( $T_c=25$ )		
パルスドレイン電流 Pulsed Drain Current	$I_{DM}$	170 ( $T_c=25$ )		A
全損失 Total Power Dissipation	$P_D$	730 ( $T_c=25$ )		W
動作接合温度範囲 Operating Junction Temperature Range	$T_{jw}$	- 40 ~ +150		
保存温度範囲 Storage Temperature Range	$T_{stg}$	- 40 ~ +125		
絶縁耐圧 RMS Isolation Voltage	$V_{iso}$	2000		V
		端子 - ベース間, AC1 分間 Terminals to Base, AC 1 min.		
締付トルク Mounting Torque	$F_{tor}$	3.0 ( 本体取付 Module Base to Heat sink )		N · m
		2.0 ( ネジ端子部 Bus bar to Main Terminals )		

電気的特性 Electrical Characteristics (@Tc = 25 unless otherwise noted)

項目 Characteristic	記号 Symbol	条件 Condition	特性値(最大) Maximum Value			単位 Unit
			最小 Min.	標準 Typ.	最大 Max.	
ドレイン遮断電流 Zero Gate Voltage Drain Current	IDSS	VDS = VDSS, VGS = 0V			1	mA
		Tj = 125, VDS = VDSS, VGS = 0V			4	
ゲート・ソース間しきい値電圧 Gate-Source Threshold Voltage	VGS(th)	VDS = VGS, ID = 1mA	2	3.1	4	V
ゲート・ソース間漏れ電流 Gate-Source Leakage Current	IGSS	VGS = ±20V, VDS = 0V			1	μA
ドレイン・ソース間オン抵抗(MOSFET部) Static Drain-Source On-Resistance	rD(on)	VGS = 10V, ID = 40A		75	85	m
ドレイン・ソース間オン電圧 Drain-Source On-Voltage	VD(on)	VGS = 10V, ID = 40A		3.5	3.9	V
順伝達コンダクタンス Forward Transconductance	gfg	VDS = 15V, ID = 40A		65		S
入力容量 Input Capacitance	Ciss	VGS = 0V VDS = 25V f = 1MHz		13		nF
出力容量 Output Capacitance	Coss			2.2		nF
帰還容量 Reverse Transfer Capacitance	Crss			0.45		nF
ターン・オン遅延時間 Turn-On Delay Time	t(on)			140		ns
上昇時間 Rise Time	tr	VDD = 1/2VDSS ID = 40A		110		ns
ターン・オン遅延時間 Turn-Off Delay Time	t(off)	VGS = -5V, +10V RG = 7		300		ns
下降時間 Fall Time	tr			50		ns

内部ダイオード定格・特性 Source-Drain Diode Ratings and Characteristics (@Tc = 25 unless otherwise noted)

項目 Characteristic	記号 Symbol	条件 Condition	特性値(最大) Maximum Value			単位 Unit
			最小 Min.	標準 Typ.	最大 Max.	
ソース電流(連続) Continuous Source Current	IS	D. C.			60	A
パルスソース電流 Pulsed Source Current	ISM				170	A
ダイオード順電圧 Diode Forward Voltage	VSD	IS = 85A			2.0	V
逆回復時間 Reverse Recovery Time	trr	IS = 85A - dis/dt = 100A/μs		100		ns
逆回復電荷 Reverse Recovery Charge	Qr			0.15		μC

熱抵抗特性 Thermal Characteristics

項目 Characteristic	記号 Symbol	条件 Condition	特性値(最大) Maximum Value			単位 Unit
			最小 Min.	標準 Typ.	最大 Max.	
熱抵抗(接合部 - ケース間) Thermal Resistance, Junction to Case	Rth(j-c)	MOSFET			0.171	/W
		Diode			1.2	
接触熱抵抗(ケース - 冷却フィン間) Thermal Resistance, Case to Heatsink	Rth(c-f)	サーマルコンパウンド塗布 Mounting surface flat, smooth, and greased			0.1	

定格・特性曲線

Fig. 1 Typical Output Characteristics

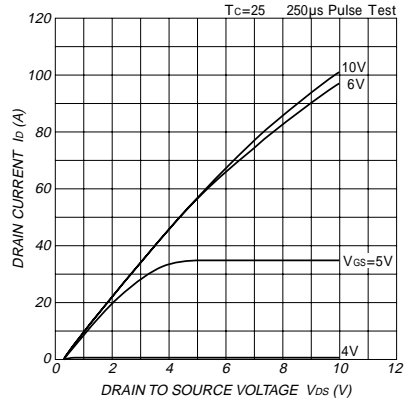

Fig. 2 Typical Drain-Source On-Voltage Vs. Gate-Source Voltage

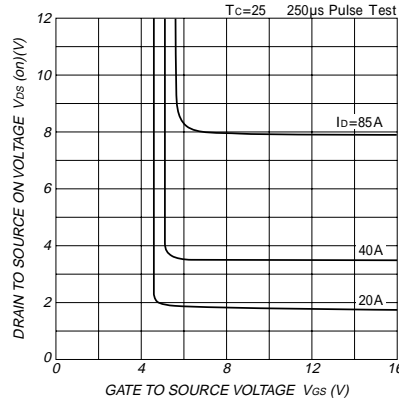

Fig. 3 Typical Drain-Source On Voltage Vs. Junction Temperature

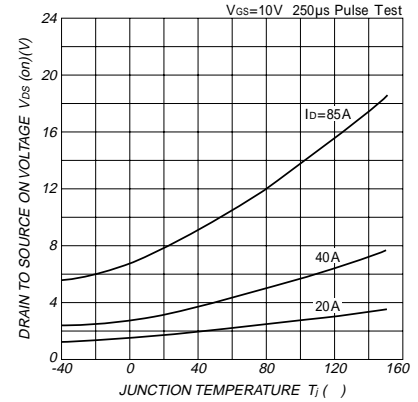

Fig. 4 Typical Capacitance Vs. Drain-Source Voltage

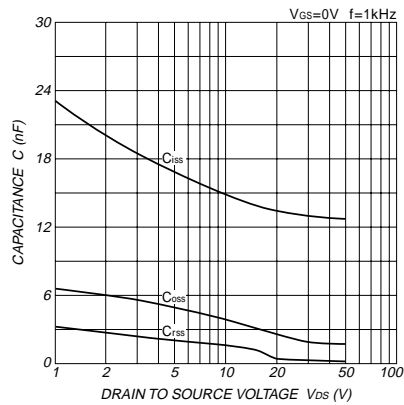

Fig. 5 Typical Gate Charge Vs. Gate-Source Voltage

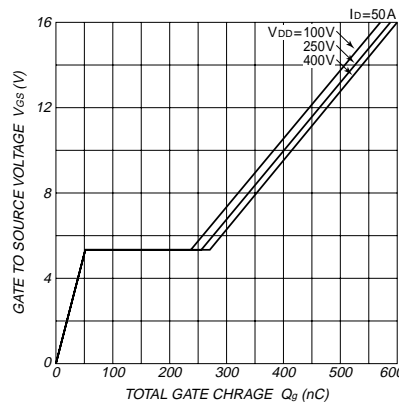

Fig. 6 Typical Switching Time Vs. Series Gate Impedance

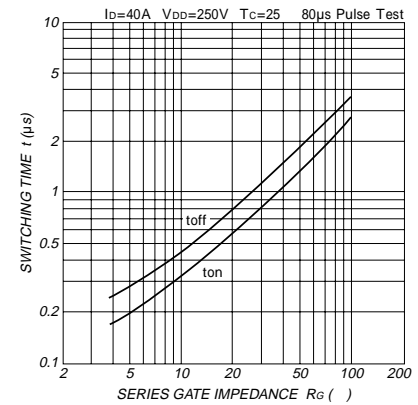

Fig. 7 Typical Switching Time Vs. Drain Current

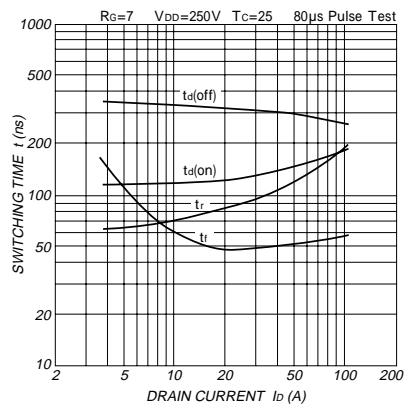

Fig. 8 Typical Source-Drain Diode Forward Characteristics

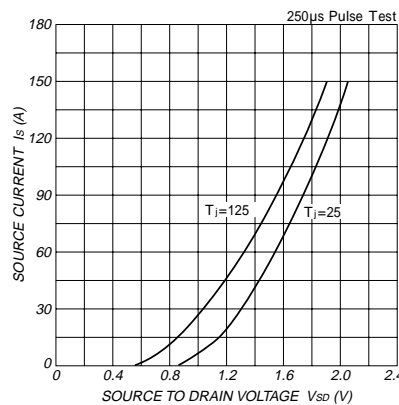

Fig. 9 Typical Reverse Recovery Characteristics

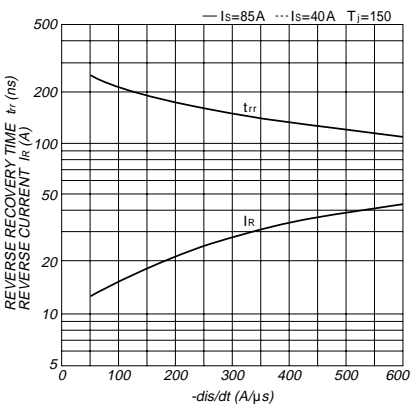

Fig. 10 Maximum Safe Operating Area

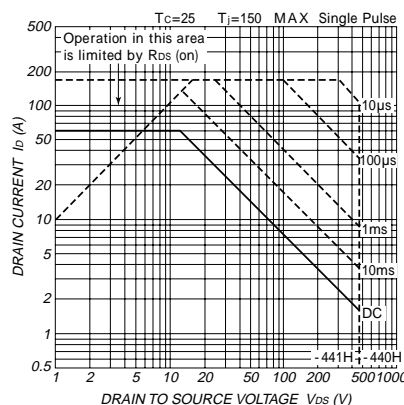

Fig. 11-1 Normalized Transient Thermal Impedance(MOSFET)

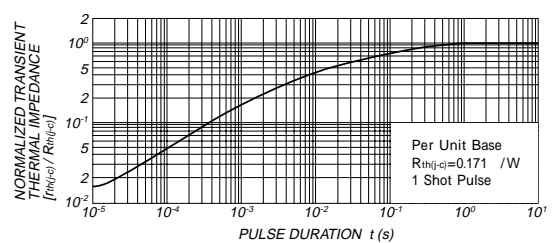

Fig. 11-2 Normalized Transient Thermal Impedance(DIODE)

