

FRD

50A Avg 400 Volts

PC50F4
PD50F4

回路図 CIRCUIT

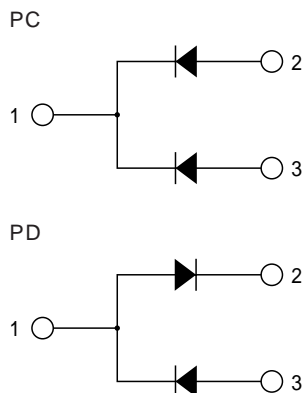

外形寸法図 OUTLINE DRAWING (単位 Dimension : mm)

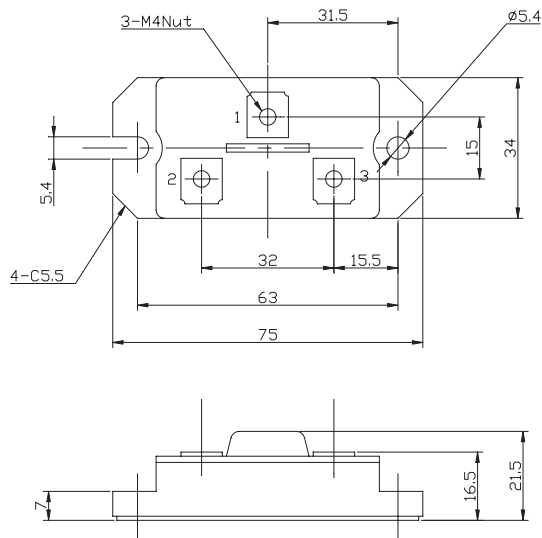

最大定格 Maximum Ratings

項目 Parameter	記号 Symbol	耐压クラス Grade	単位 Unit
		PC50F4/PD50F4	
くり返しピーク逆電圧 Repetitive Peak Reverse Voltage	*1 V _{RRM}	400	V
非くり返しピーク逆電圧 Non Repetitive Peak Reverse Voltage	*1 V _{RSM}	440	V

項目 Parameter	記号 Symbol	条件 Conditions	定格値 Max. Rated Value	単位 Unit		
平均整流電流 Average Rectified Output Current	*1 I _{O(AV)}	商用周波数 180° 通電 Half Sine Wave T _c = 100	50	A		
実効順電流 RMS Forward Current	*1 I _{F(RMS)}		78	A		
サージ順電流 Surge Forward Current	*1 I _{FSM}	50Hz正弦半波, 1 サイクル, 非くり返し Half Sine Wave, 1Pulse, Non-Repetitive	800	A		
電流二乗時間積 I Squared t	*1 I ² t	2 ~ 10ms	3200	A ² s		
動作接合温度範囲 Operating Junction Temperature Range	T _{jw}		- 40 ~ + 150			
保存温度範囲 Storage Temperature Range	T _{stg}		- 40 ~ + 125			
絶縁耐圧 Isolation Voltage	V _{iso}	端子 - ベース間, AC 1 分間 Terminal to Base, AC 1 min.	2000	V		
締付トルク Mounting Torque	ベース部 Mounting	F	サーマルコンパウンド塗布 Greased	M5	2.4 ~ 2.8	N・m
	主端子部 Terminal			M4	1.2 ~ 1.6	N・m

電気的特性 Electrical Characteristics

項目 Parameter	記号 Symbol	条件 Conditions	特性値 (最大) Maximum Value	単位 Unit
ピーク逆電流 Peak Reverse Current	*1 I _{RM}	T _j =150 , V _{RM} =V _{RRM}	10	mA
ピーク順電圧 Peak Forward Voltage	*1 V _{FM}	T _j =25 , I _{FM} =50A	1.20	V
逆回復時間 Reverse Recovery Time	*1 t _{rr}	T _j =25 , I _{FM} =10A , - di/dt = 50A/μs	80	ns
熱抵抗 Thermal Resistance	*1 R _{th(j-c)}	接合部 - ケース間 Junction to Case	0.8	/W
接触熱抵抗 Thermal Resistance	R _{th(c-f)}	ケース - フィン間 (トータル), サーマルコンパウンド塗布 Case to Fin, Total, Greased	0.1	/W
内部リードインダクタンス Internal Inductance	L _s	アノード端子 - カソード端子間 Anode Terminal to Cathode Terminal	30	nH

質量...約105g
Approximate Weight

*1 : 1 アーム当りの値 Value Per 1 Arm.

定格・特性曲線

順電圧特性
FORWARD CURRENT VS. VOLTAGE

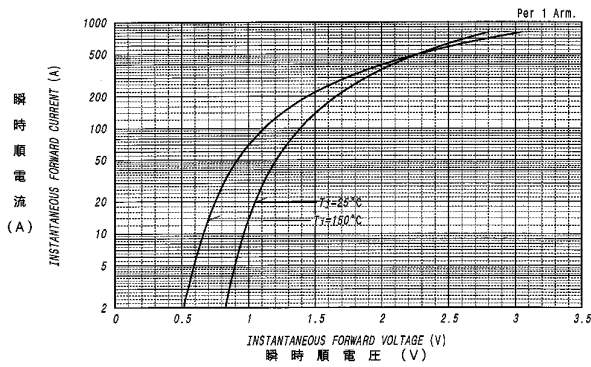

過渡熱抵抗特性
MAXIMUM TRANSIENT THERMAL IMPEDANCE

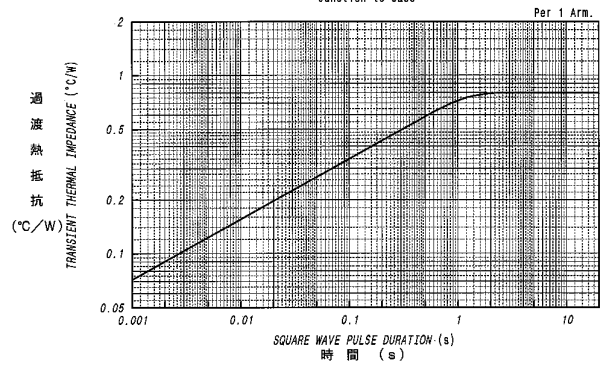

平均順電力損失特性
AVERAGE FORWARD POWER DISSIPATION

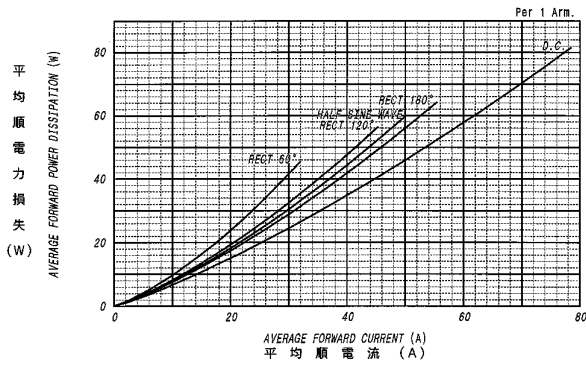
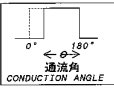

逆回復特性(代表例)
REVERSE RECOVERY CHARACTERISTICS (TYP)

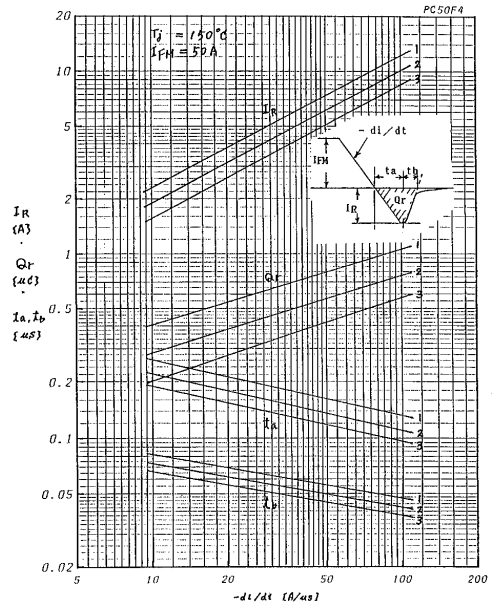

平均順電流 - ケース温度定格
AVERAGE FORWARD CURRENT VS. CASE TEMPERATURE

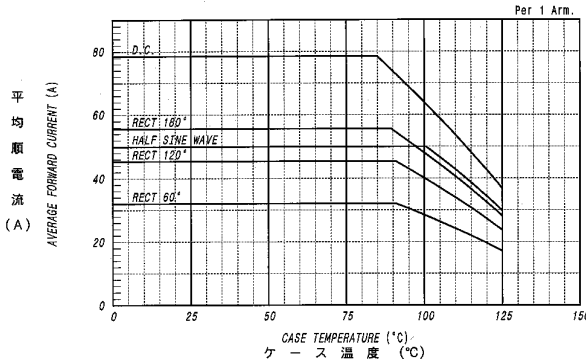
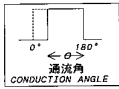

逆回復特性(代表例)
REVERSE RECOVERY CHARACTERISTICS (TYP)

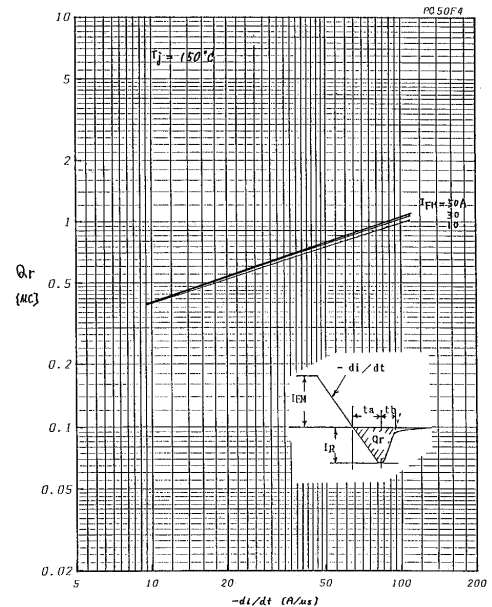

サージ順電流定格
SURGE CURRENT RATINGS

f=50Hz, Half Sine Wave, Non-Repetitive, Tj=150°C

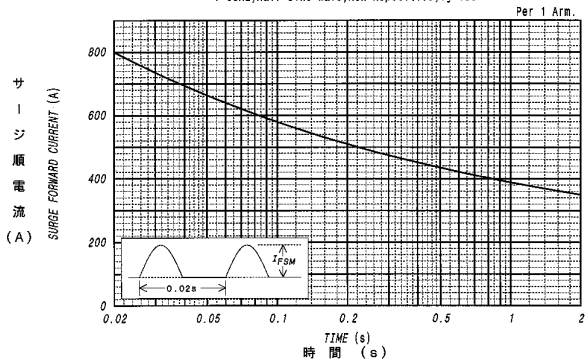

FRD・SBDモジュール