

# THYRISTOR MODULE

## PK(PD,PE,KK)55GB

UL;E76102(M)

Power Thyristor/Diode Module **PK55GB** series are designed for various rectifier circuits and power controls. For your circuit application. following internal connections and wide voltage ratings up to 800V are available. and electrically isolated mounting base make your mechanical design easy.

- $I_{T(AV)}$  55A,  $I_{T(RMS)}$  86A,  $I_{TSM}$  1100A
- $di/dt$  150 A/ $\mu$ s
- $dv/dt$  500V/ $\mu$ s

### (Applications)

Various rectifiers  
AC/DC motor drives  
Heater controls  
Light dimmers  
Static switches

### Internal Configurations

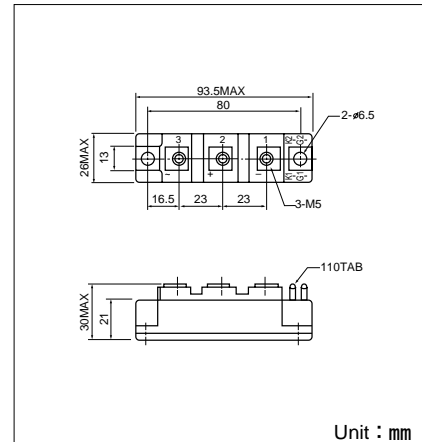
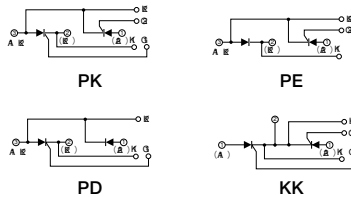

### Maximum Ratings

Symbol	Item	Ratings				Unit
		PK55GB40 KK55GB40	PD55GB40 PE55GB40	PK55GB80 KK55GB80	PD55GB80 PE55GB80	
V <sub>RRM</sub>	* Repetitive Peak Reverse Voltage	400		800		V
V <sub>RSM</sub>	* Non-Repetitive Peak Reverse Voltage	480		960		V
V <sub>DRM</sub>	Repetitive Peak Off-State Voltage	400		800		V

Symbol	Item	Conditions	Ratings	Unit	
$I_{T(AV)}$	* Average On-State Current	Single phase, half wave, 180° conduction, T <sub>c</sub> : 89°C	55	A	
$I_{T(RMS)}$	* R.M.S. On-State Current	Single phase, half wave, 180° conduction, T <sub>c</sub> : 89°C	86	A	
$I_{TSM}$	* Surge On-State Current	1/2 cycle, 50Hz/60Hz, peak Value, non-repetitive	1000/1100	A	
$I^2t$	* $I^2t$	Value for one cycle of surge current	5000	A <sup>2</sup> S	
P <sub>GM</sub>	Peak Gate Power Dissipation		10	W	
P <sub>G(AV)</sub>	Average Gate Power Dissipation		3	W	
I <sub>FGM</sub>	Peak Gate Current		3	A	
V <sub>FGM</sub>	Peak Gate Voltage (Forward)		10	V	
V <sub>RGM</sub>	Peak Gate Voltage (Reverse)		5	V	
$di/dt$	Critical Rate of Rise of On-State Current	I <sub>G</sub> =100mA, T <sub>j</sub> =25°C, V <sub>D</sub> =1/2V <sub>DRM</sub> , di <sub>G</sub> /dt=0.1A/ $\mu$ s	150	A/ $\mu$ s	
V <sub>ISO</sub>	* Isolation Breakdown Voltage (R.M.S.)	A.C.1minute	2500	V	
T <sub>j</sub>	* Operating Junction Temperature		-40 t + 125	°C	
T <sub>stg</sub>	* Storage Temperature		-40 t + 125	°C	
	Mounting Torque	Mounting (M6)	Recommended Value 2.5-3.9 (25-40)	4.7 (48)	N·m (kgf·cm)
		Terminal (M5)	Recommended Value 1.5-2.5 (15-25)	2.7 (28)	
	Mass		170	g	

### Electrical Characteristics

Symbol	Item	Conditions	Ratings	Unit
I <sub>DRM</sub>	Repetitive Peak Off-State Current, max.	at V <sub>DRM</sub> , single phase, half wave, T <sub>j</sub> =125°C	10	mA
I <sub>RRM</sub>	* Repetitive Peak Reverse Current, max.	at V <sub>DRM</sub> , single phase, half wave, T <sub>j</sub> =125°C	10	mA
V <sub>TM</sub>	* Peak On-State Voltage, max.	On-State Current 165A, T <sub>j</sub> =125°C Inst. measurement	1.35	V
I <sub>GT</sub> /V <sub>GT</sub>	Gate Trigger Current/Voltage, max.	T <sub>j</sub> =25°C, I <sub>T</sub> =1A, V <sub>D</sub> =6V	100/3	mA/V
V <sub>GD</sub>	Non-Trigger Gate, Voltage. min.	T <sub>j</sub> =125°C, V <sub>D</sub> =1/2V <sub>DRM</sub>	0.25	V
t <sub>gt</sub>	Turn On Time, max.	I <sub>T</sub> =55A, I <sub>G</sub> =100mA, T <sub>j</sub> =25°C, V <sub>D</sub> =1/2V <sub>DRM</sub> , di <sub>G</sub> /dt=0.1A/ $\mu$ s	10	$\mu$ s
$dv/dt$	Critical Rate of Rise of Off-State Voltage, min.	T <sub>j</sub> =125°C, V <sub>D</sub> =2/3V <sub>DRM</sub> , Exponential wave.	500	V/ $\mu$ s
I <sub>H</sub>	Holding Current, typ.	T <sub>j</sub> =25°C	50	mA
I <sub>L</sub>	Latching Current, typ.	T <sub>j</sub> =25°C	100	mA
R <sub>th(j-c)</sub>	* Thermal Impedance, max.	Junction to case	0.50	°C/W

\* mark : Thyristor and Diode part. No mark : Thyristor part

