

IGBT MODULE

1200V / 10A / PIM

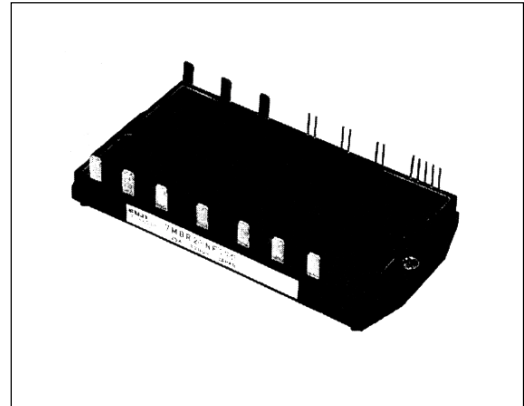

■ Features

- High Speed Switching
- Voltage Drive
- Low Inductance Module Structure
- Converter Diode Bridge Dynamic Brake Circuit

■ Applications

- Inverter for Motoe Drive
- AC and DC Servo Drive Amplifier
- Uninterruptible Power Supply

■ Maximum ratings and characteristics

● Absolute maximum ratings (Tc=25°C unless without specified)

Item	Symbol	Condition	Rating	Unit	
Inverter	Collector-Emitter voltage	V _{CES}	1200	V	
	Gate-Emitter voltage	V _{GES}	±20	V	
	Collector current	DC	I _C	10	A
		1ms	I _{CP}	20	A
		DC	-I _C	10	A
Collector power dissipation	1 device	P _C	60	W	
Brake	Collector-Emitter voltage	V _{CES}	1200	V	
	Gate-Emitter voltage	V _{GES}	±20	V	
	Collector current	DC	I _C	5	A
		1ms	I _{CP}	12.5	A
	Collector power dissipation	1 device	P _C	40	W
	Repetitive peak reverse voltage	V _{RRM}		1200	V
	Average forward current	I _{F(AV)}		1	A
Surge current	I _{FSM}	10ms	50	A	
Converter	Repetitive peak reverse voltage	V _{RRM}	1600	V	
	Non-Repetitive peak reverse voltage	V _{RSM}	1700	V	
	Average output current	I _O	50Hz/60Hz sine wave	25	A
	Surge current (Non-Repetitive)	I _{FSM}	T _j =150°C, 10ms	320	A
	I _{pt} (Non-Repetitive)		T _j =150°C, 10ms	512	A ² s
Operating junction temperature	T _j		+150	°C	
Storage temperature	T _{stg}		-40 to +125	°C	
Isolation voltage	V _{iso}	AC : 1 min.	AC 2500	V	
Mounting screw torque			1.7 *1	N·m	

*1 Recommendable value : 1.3 to 1.7 N·m (M4)

● Electrical characteristics (Tj=25°C unless without specified)

Item	Symbol	Condition	Characteristics			Unit	
			Min.	Typ.	Max.		
Inverter (IGBT)	Zero gate voltage collector current	ICES	VCE=1200V, VGE=0V, Tj=25°C			1.0	mA
	Gate-Emitter leakage current	IGES	VCE=0V, VGE=±20V			100	nA
	Gate-Emitter threshold voltage	VGE(th)	VCE=20V, Ic=10mA			4.5	V
	Collector-Emitter saturation voltage	VCE(sat)	VGE=15V, Ic=10A			3.3	V
	Collector-Emitter voltage	-VCE	-Ic=10A			3.0	V
	Input capacitance	Cies	VGE=0V, VCE=10V, f=1MHz			2100	pF
	Switching time	ton	VCC=600V			1.2	µs
		tr	Ic=10A			0.6	µs
		toff	VGE=±15V			1.5	µs
		tf	RG=62 ohm			0.5	µs
Reverse recovery time of FRD	trr	If=10A, VGE=-10V, -di/dt=50A/µs			350	ns	
Brake (IGBT)	Zero gate voltage collector current	ICES	VCE=1200V, VGE=0V			1.0	mA
	Gate-Emitter leakage current	IGES	VCE=0V, VGE=±20V			100	nA
	Collector-Emitter saturation voltage	VCE(sat)	Ic=5A, VGE=15V			3.55	V
	Switching time	ton	VCC=600V			0.8	µs
		tr	Ic=5A			0.6	µs
		toff	VGE=±15V			1.5	µs
tf		RG= 120 ohm			0.5	µs	
Brake (FWD)	Reverse current	I _{RRM}					
	Reverse recovery time	trr					
Converter	Forward voltage	V _{FM}	If=25A			1.4	V
	Reverse current	I _{RRM}	VR=V _{RRM}			1.0	mA

● Thermal Characteristics

Item	Symbol	Condition	Characteristics			Unit
			Min.	Typ.	Max.	
Thermal resistance (1 device)	Rth(j-c)	Inverter IGBT			1.67	°C/W
		Inverter FRD			3.30	
		Brake IGBT			3.12	
		Converter Diode			3.40	
Contact thermal resistance *	Rth(c-f)	With thermal compound		0.05		

* This is the value which is defined mounting on the additional cooling fin with thermal compound

■ Equivalent Circuit Schematic

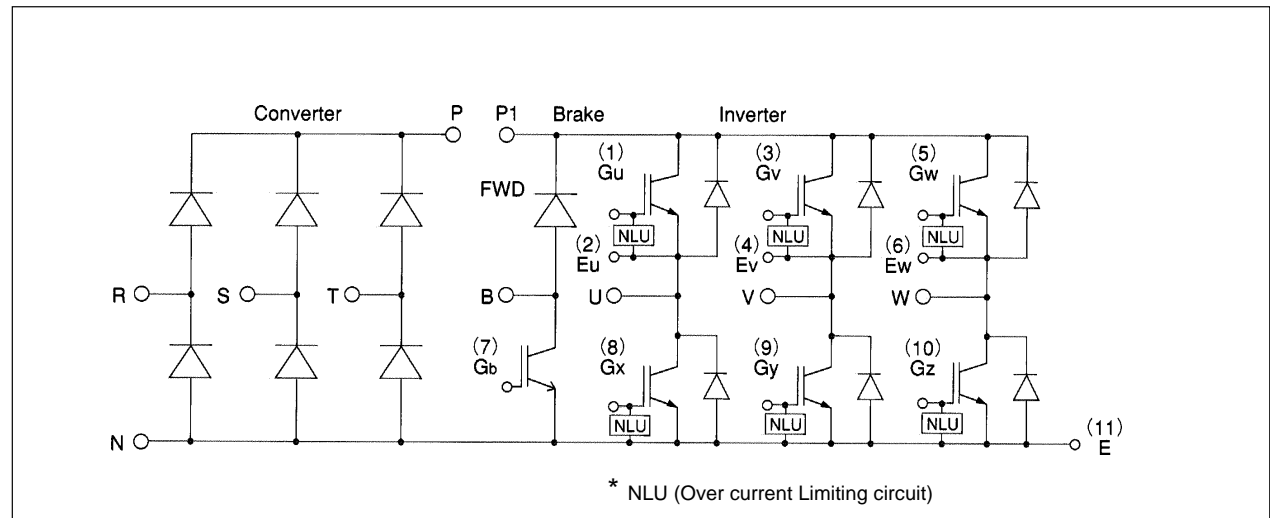

■ Characteristics (Representative)

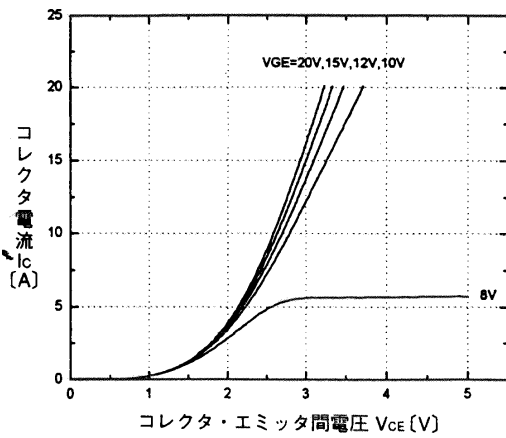

コレクタ電流-コレクタ・エミッタ間電圧特性 ($T_j=25^\circ\text{C}$) <INV部>
Collector current vs. Collector-Emitter voltage <INV>

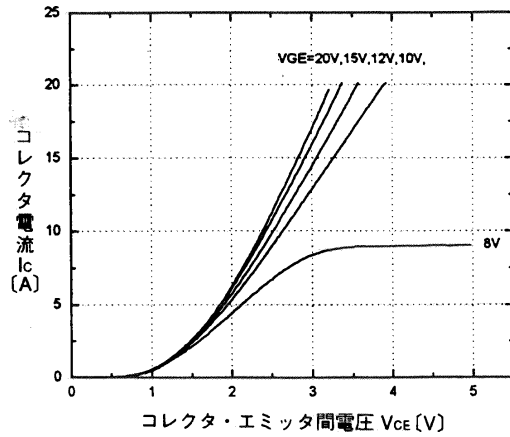

コレクタ電流-コレクタ・エミッタ間電圧特性 ($T_j=125^\circ\text{C}$) <INV部>
Collector current vs. Collector-Emitter voltage <INV>

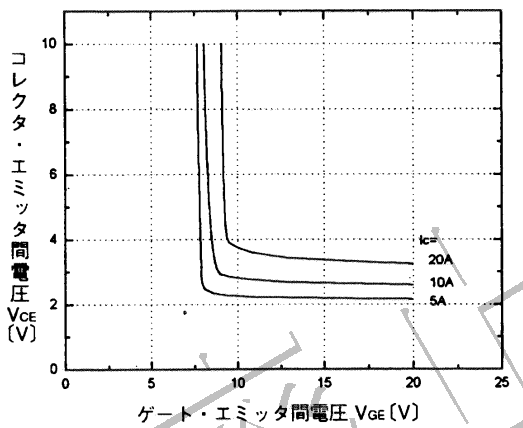

コレクタ・エミッタ間電圧-ゲート・エミッタ間電圧特性 ($T_j=25^\circ\text{C}$) <INV部>
Collector-Emitter voltage vs. Gate-Emitter voltage <INV>

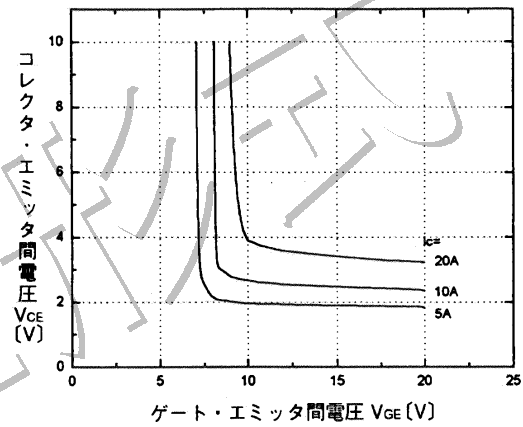

コレクタ・エミッタ間電圧-ゲート・エミッタ間電圧特性 ($T_j=125^\circ\text{C}$) <INV部>
Collector-Emitter voltage vs. Gate-Emitter voltage <INV>

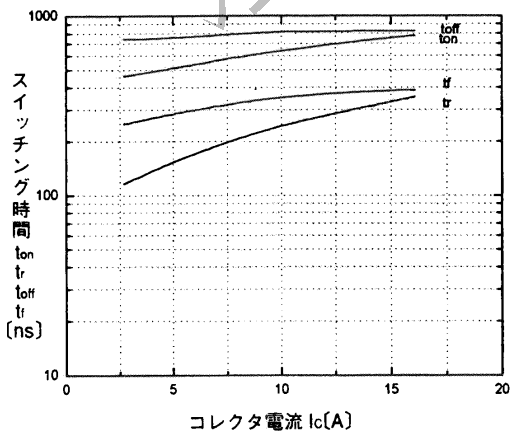

スイッチング時間-コレクタ電流特性 ($T_j=25^\circ\text{C}$) <INV部>
Switching time vs. Collector current <INV>

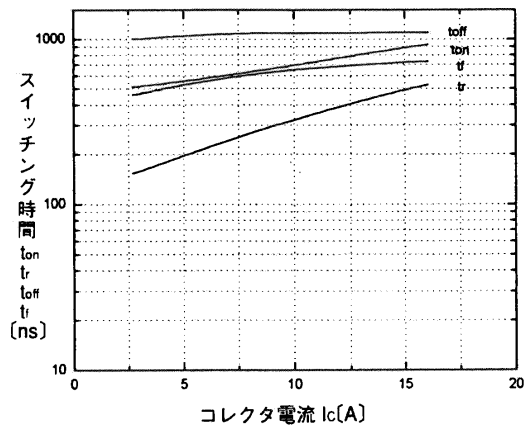

スイッチング時間-コレクタ電流特性 ($T_j=125^\circ\text{C}$) <INV部>
Switching time vs. Collector current <INV>

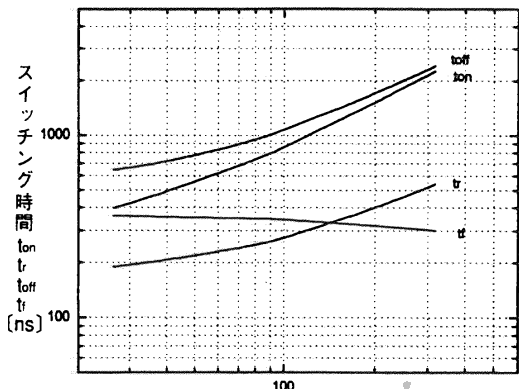

ゲート抵抗 R_g (Ω)
 スイッチング時間-ゲート抵抗特性 ($T_j=25^\circ\text{C}$) <INV部>
 Switching time vs. Gate resistance <INV>

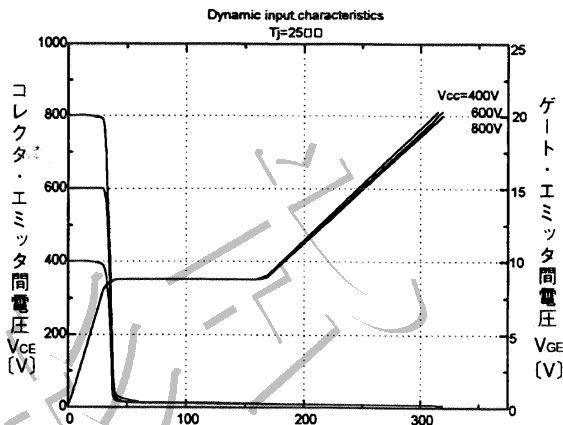

充電電荷量 Q_g (nC)
 ダイナミック入力特性 ($T_j=25^\circ\text{C}$) <INV部>
 Dynamic input characteristic <INV>

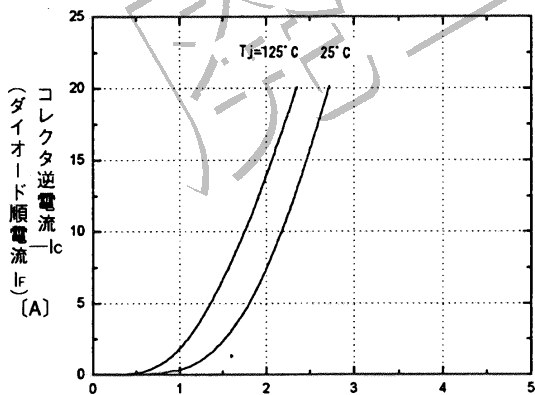

エミッタ・コレクタ間電圧 V_{EC} (V)
 (ダイオード順電圧 V_f)
 高速フリーホイールダイオード順電圧特性 <INV部>
 Forward voltage of free wheel diode <INV>

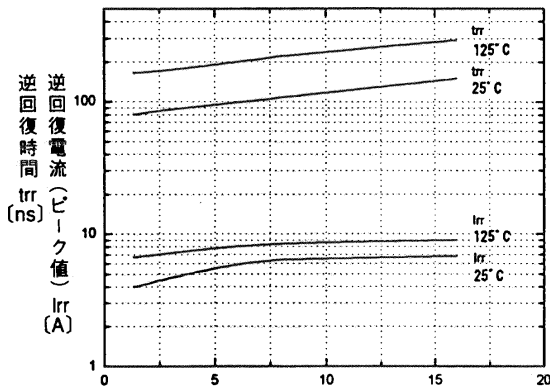

逆回復時間 t_{rr} (ns)
 逆回復電流 (ピーク値) I_{rr} (A)
 T_{rr} , I_{rr} - I_f 特性 <INV部>
 T_{rr} , I_{rr} - I_f <INV>

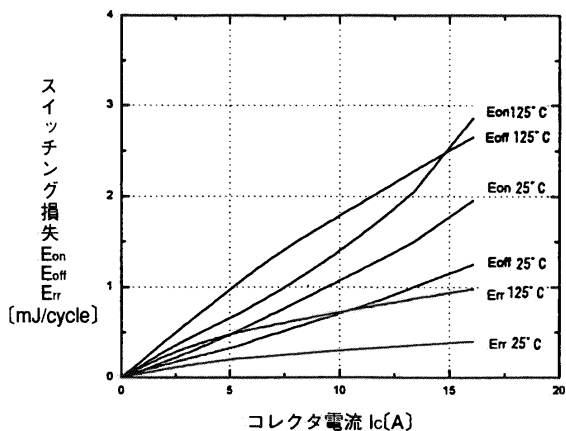

スイッチング損失 E_{on} , E_{off} , E_{rr} (mJ/cycle)
 スイッチング損失-コレクタ電流特性 <INV部>
 Switching loss vs. Collector current <INV>

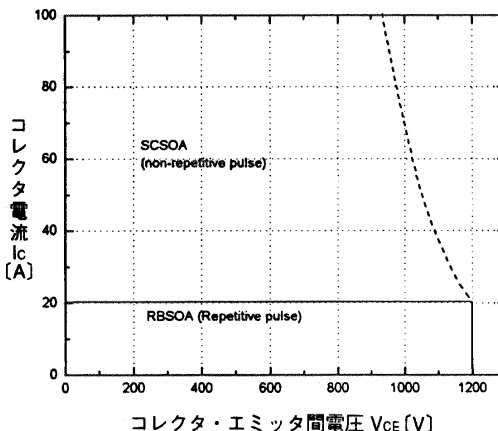

コレクタ電流 I_c (A)
 コレクタ・エミッタ間電圧 V_{CE} (V)
 安全動作領域 (逆バイアス) ($T_j \leq 125^\circ\text{C}$) <INV部>
 Reverse biased safe operating area <INV>

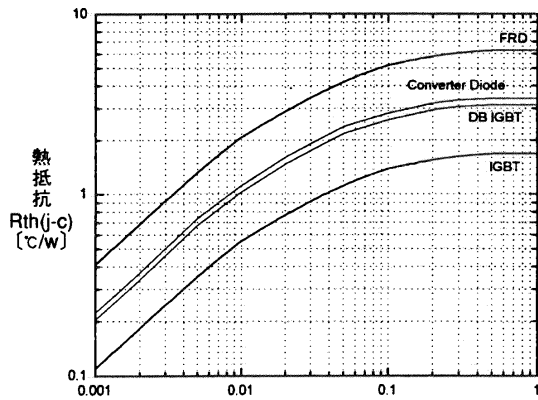

熱抵抗 $R_{th(j-c)}$ [°C/W]
パルス幅 P_w [S]
過渡熱抵抗特性
Transient thermal resistance

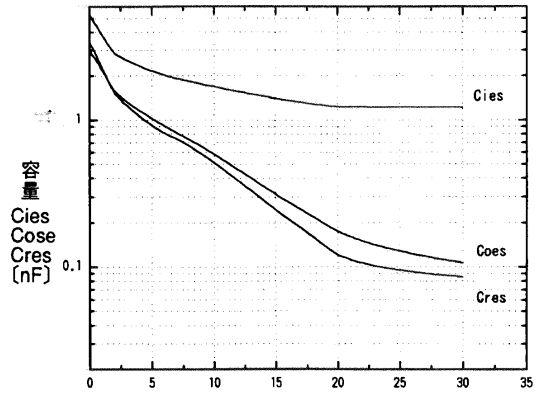

容量 C_{ies} , C_{oes} , C_{res} [nF]
コレクタ・エミッタ間電圧 V_{ce} [V]
容量-コレクタ・エミッタ間電圧特性 ($T_j=25^\circ\text{C}$) <INV部>
Capacitance vs. Collector-Emitter voltage <INV>

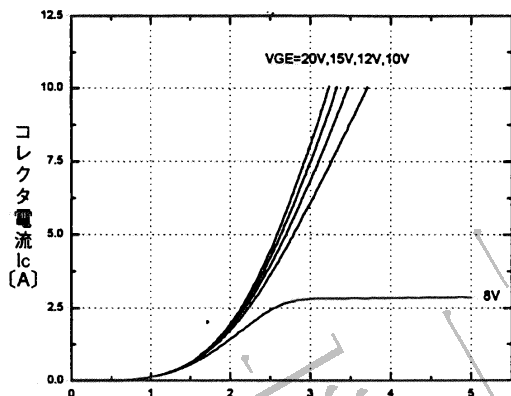

コレクタ電流 I_c [A]
コレクタ・エミッタ間電圧 V_{ce} [V]
コレクタ電流-コレクタ・エミッタ間電圧特性 ($T_j=25^\circ\text{C}$) <ブレーキ部>
Collector current vs. Collector-Emitter voltage <BRAKE>

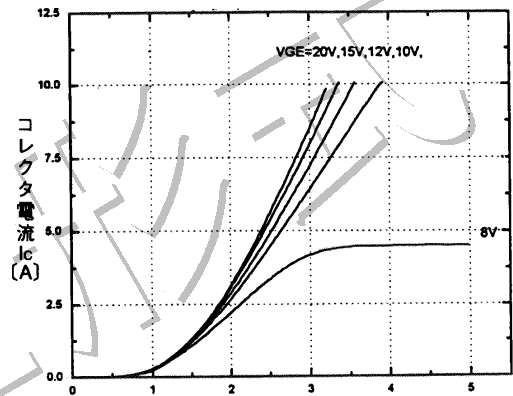

コレクタ電流 I_c [A]
コレクタ・エミッタ間電圧 V_{ce} [V]
コレクタ電流-コレクタ・エミッタ間電圧特性 ($T_j=125^\circ\text{C}$) <ブレーキ部>
Collector current vs. Collector-Emitter voltage <BRAKE>

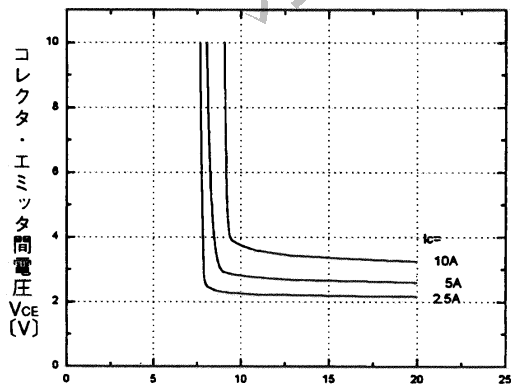

コレクタ・エミッタ間電圧 V_{ce} [V]
ゲート・エミッタ間電圧 V_{ge} [V]
コレクタ・エミッタ間電圧-ゲート・エミッタ間電圧特性 ($T_j=25^\circ\text{C}$) <ブレーキ部>
Collector-Emitter voltage vs. Gate-Emitter voltage <BRAKE>

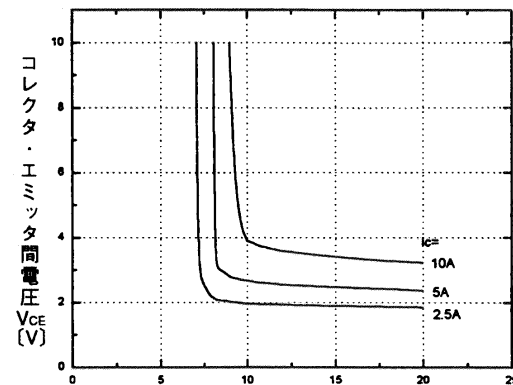

コレクタ・エミッタ間電圧 V_{ce} [V]
ゲート・エミッタ間電圧 V_{ge} [V]
コレクタ・エミッタ間電圧-ゲート・エミッタ間電圧特性 ($T_j=125^\circ\text{C}$) <ブレーキ部>
Collector-Emitter voltage vs. Gate-Emitter voltage <BRAKE>

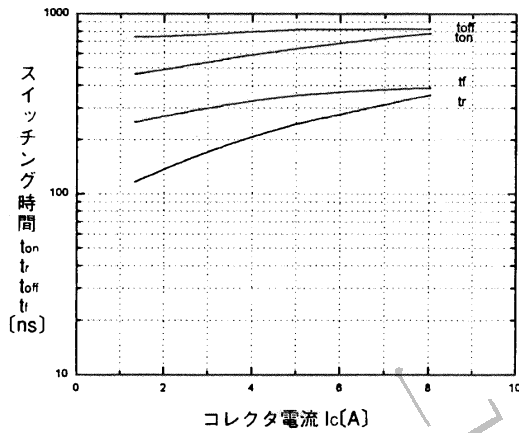

スイッチング時間-コレクタ電流特性 ($T_j = 25^\circ\text{C}$) <ブレーキ部>
Switching time vs. Collector current <BRAKE>

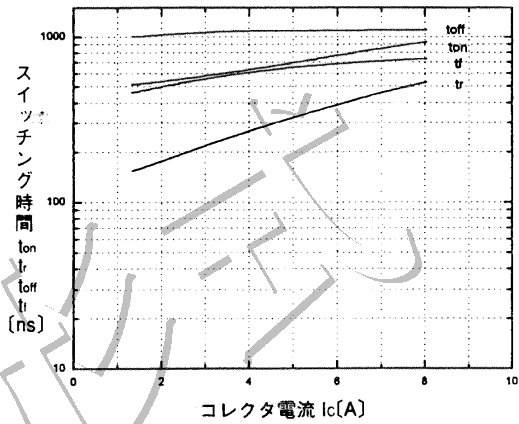

スイッチング時間-コレクタ電流特性 ($T_j = 125^\circ\text{C}$) <ブレーキ部>
Switching time vs. Collector current <BRAKE>

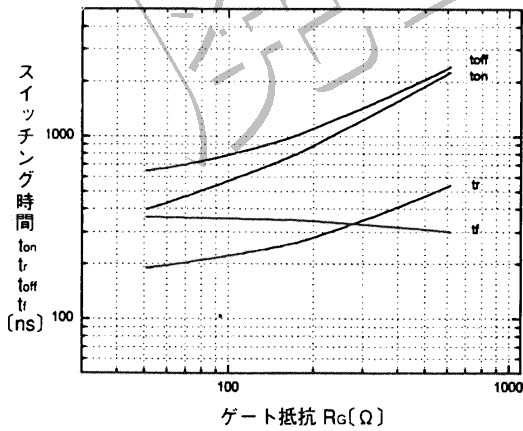

スイッチング時間-ゲート抵抗特性 ($T_j = 25^\circ\text{C}$) <ブレーキ部>
Switching time vs. Gate resistance <BRAKE>

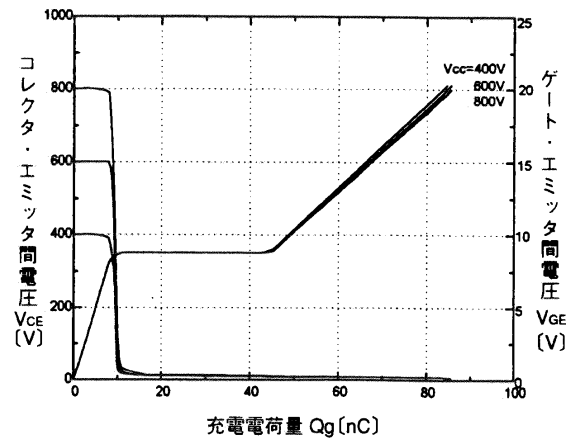

ダイナミック入力特性 ($T_j = 25^\circ\text{C}$) <ブレーキ部>
Dynamic input characteristic <BRAKE>

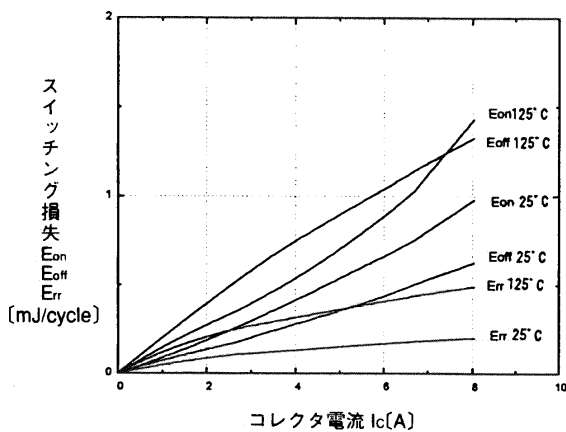

スイッチング損失-コレクタ電流特性 <ブレーキ部>
Switching loss vs. Collector current <BRAKE>

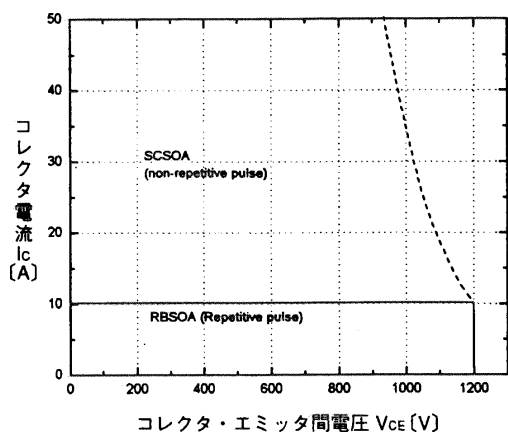

安全動作領域(逆バイアス) ($T_j \leq 125^\circ\text{C}$) <ブレーキ部>
Reverse biased safe operating area <BRAKE>

