

### IGBT MODULE

1200V / 25A / PIM

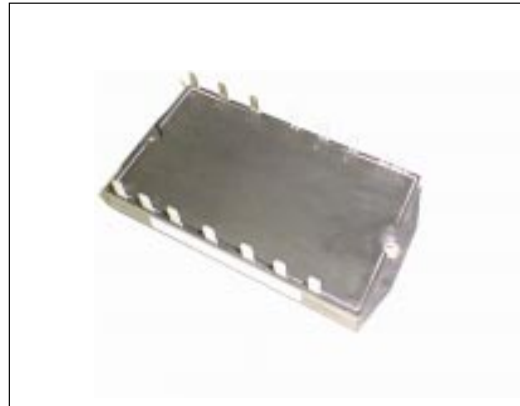

#### ■ Features

- High Speed Switching
- Voltage Drive
- Low Inductance Module Structure
- Converter Diode Bridge Dynamic Brake Circuit

#### ■ Applications

- Inverter for Motoe Drive
- AC and DC Servo Drive Amplifier
- Uninterruptible Power Supply

#### ■ Maximum ratings and characteristics

● Absolute maximum ratings (Tc=25°C unless without specified)

Item	Symbol	Condition	Rating	Unit	
Inverter	Collector-Emitter voltage	V <sub>CES</sub>	1200	V	
	Gate-Emitter voltage	V <sub>GES</sub>	±20	V	
	Collector current	I <sub>C</sub>	Continuous	25	A
		I <sub>CP</sub>	1ms	50	A
		-I <sub>C</sub>		25	A
Collector power dissipation	P <sub>C</sub>	1 device	200	W	
Brake	Collector-Emitter voltage	V <sub>CES</sub>	1200	V	
	Gate-Emitter voltage	V <sub>GES</sub>	±20	V	
	Collector current	I <sub>C</sub>	Continuous	15	A
		I <sub>CP</sub>	1ms	30	A
	Collector power dissipation	P <sub>C</sub>	1 device	120	W
	Repetitive peak reverse voltage			1200	V
	Average forward current	I <sub>F(AV)</sub>		1	A
Surge current	I <sub>FSM</sub>	10ms	50	A	
Converter	Repetitive peak reverse voltage	V <sub>RRM</sub>	1600	V	
	Non-Repetitive peak reverse voltage	V <sub>RSM</sub>	1700	V	
	Average output current	I <sub>O</sub>	50Hz/60Hz sine wave	25	A
	Surge current (Non-Repetitive)	I <sub>FSM</sub>	T <sub>j</sub> =150°C, 10ms	320	A
	I <sub>It</sub> (Non-Repetitive)		T <sub>j</sub> =150°C, 10ms	512	A <sup>2</sup> s
Operating junction temperature	T <sub>j</sub>		+150	°C	
Storage temperature	T <sub>stg</sub>		-40 to +125	°C	
Isolation voltage	V <sub>iso</sub>	AC : 1 minute	AC 2500	V	
Mounting screw torque			1.7 * <sub>1</sub>	N·m	

\*<sub>1</sub> Recommendable value : 1.3 to 1.7 N·m (M4)

● Electrical characteristics (Tj=25°C unless without specified)

Item	Symbol	Condition	Characteristics			Unit	
			Min.	Typ.	Max.		
Inverter (IGBT)	Zero gate voltage collector current	ICES	VCE=1200V, VGE=0V			1.0	mA
	Gate-Emitter leakage current	IGES	VCE=0V, VGE=±20V			20	µA
	Gate-Emitter threshold voltage	VGE(th)	VCE=20V, IC=25mA	4.5		7.5	V
	Collector-Emitter saturation voltage	VCE(sat)	VGE=15V, IC=25A			3.3	V
	Collector-Emitter voltage	-VCE	-IC=25A			3.0	V
	Input capacitance	Cies	VGE=0V, VCE=10V, f=1MHz		4000		pF
	Switching time	ton	VCC=600V			1.2	µs
		tr	IC=25A			0.6	µs
		toff	VGE=±15V			1.5	µs
		tf	RG=51 ohm			0.5	µs
Reverse recovery time of FRD	trr	IF=25A			0.35	µs	
Brake (IGBT)	Zero gate voltage collector current	ICES	VCE=1200V, VGE=0V			1.0	mA
	Gate-Emitter leakage current	IGES	VCE=0V, VGE=±20V			0.1	µA
	Collector-Emitter saturation voltage	VCE(sat)	IC=15A, VGE=15V			3.3	V
	Switching time	ton	VCC=600V			0.8	µs
		tr	IC=15A			0.6	µs
toff		VGE=±15V			1.5	µs	
tf		RG=82 ohm			0.5	µs	
Brake (FWD)	Reverse current	IRRM	VR=1200V			1	mA
	Reverse recovery time	trr				0.6	µs
Converter	Forward voltage	VFM	IF=25A			1.4	V
	Reverse current	IRRM	VR=1600V			1.0	mA

● Thermal Characteristics

Item	Symbol	Condition	Characteristics			Unit
			Min.	Typ.	Max.	
Thermal resistance ( 1 device )	Rth(j-c)	Inverter IGBT			0.63	°C/W
		Inverter FRD			1.70	
		Brake IGBT			1.04	
		Converter Diode			3.40	
Contact thermal resistance *	Rth(c-f)	With thermal compound		0.05		

\* This is the value which is defined mounting on the additional cooling fin with thermal compound

■ Equivalent Circuit Schematic

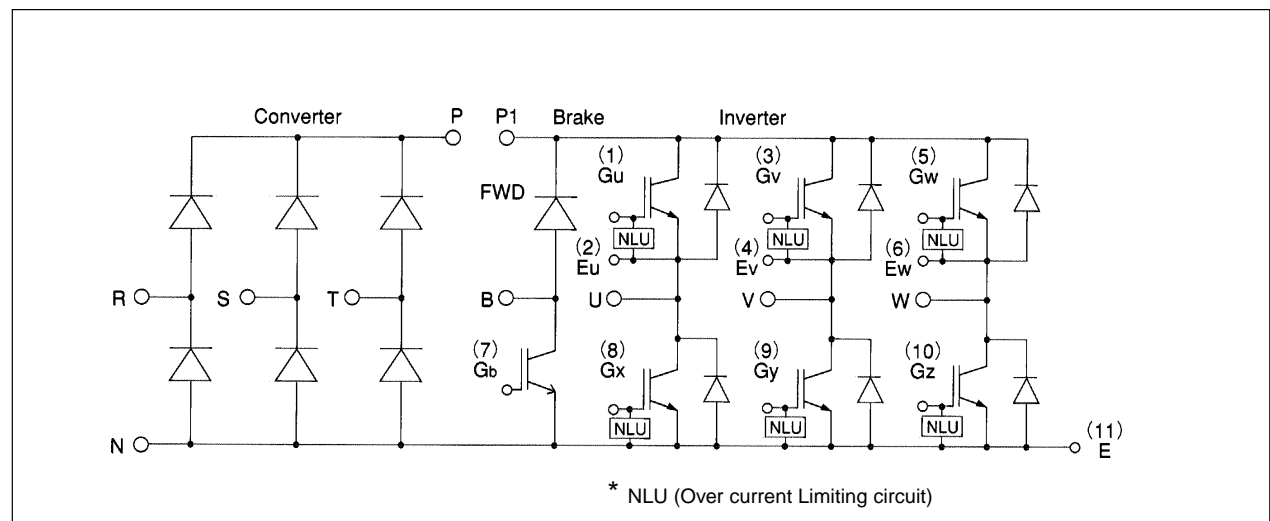

Characteristics (Representative)

Inverter

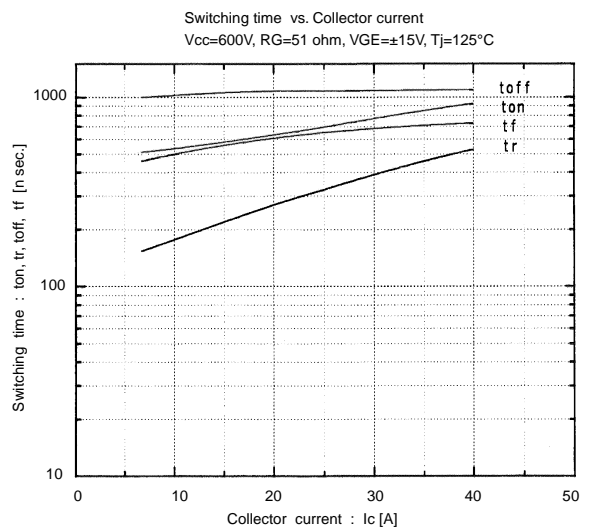
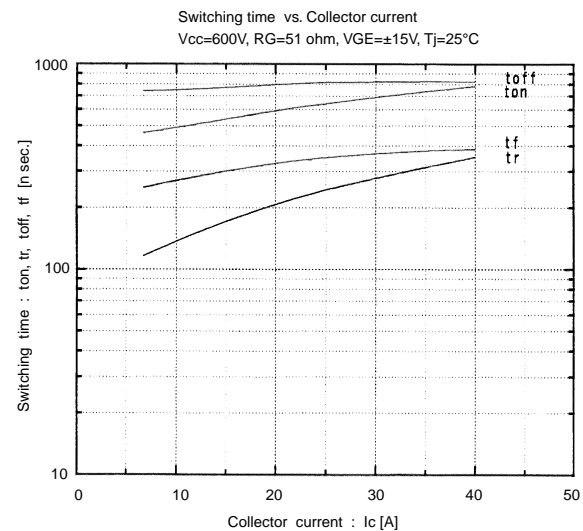
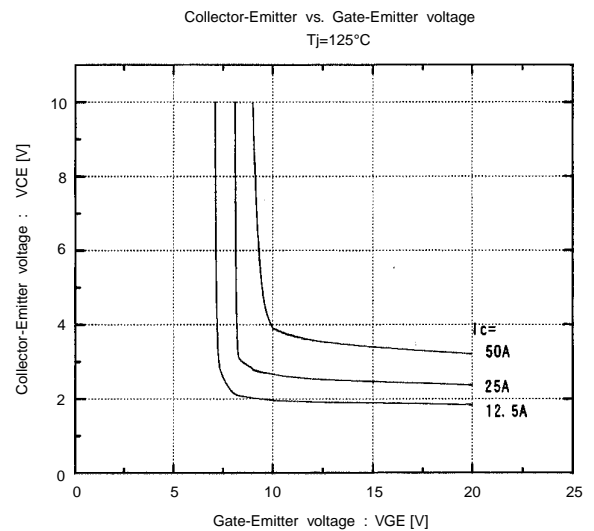
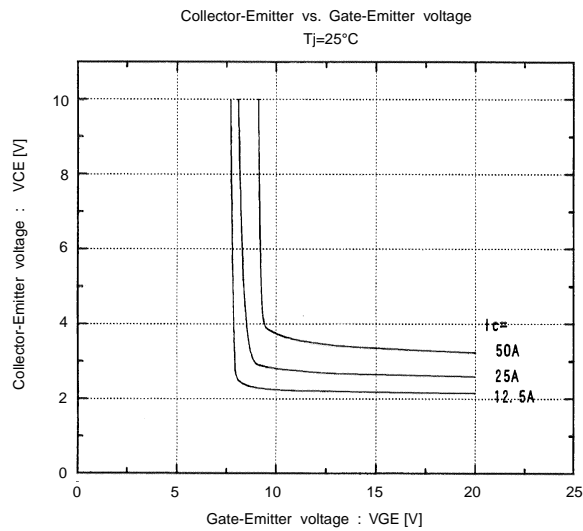
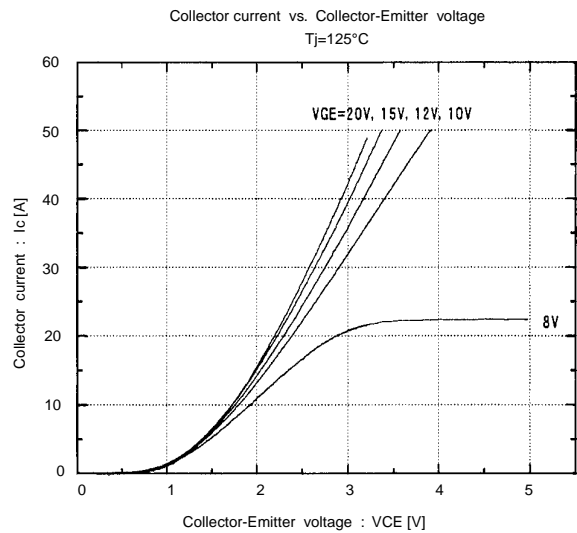
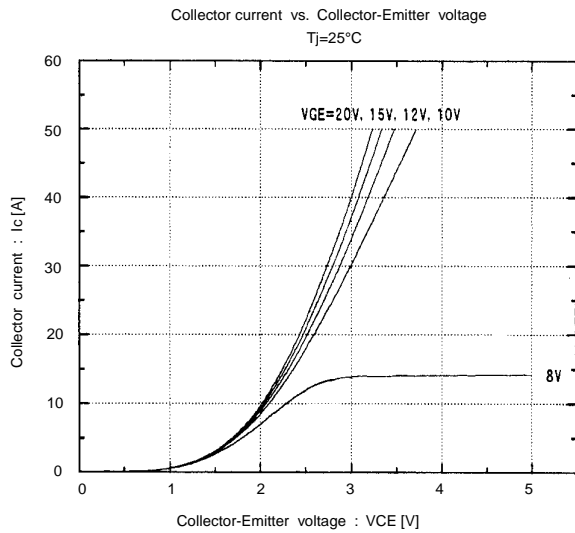

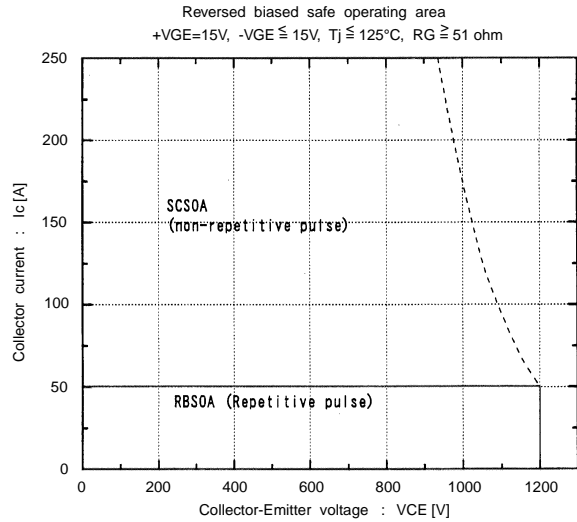
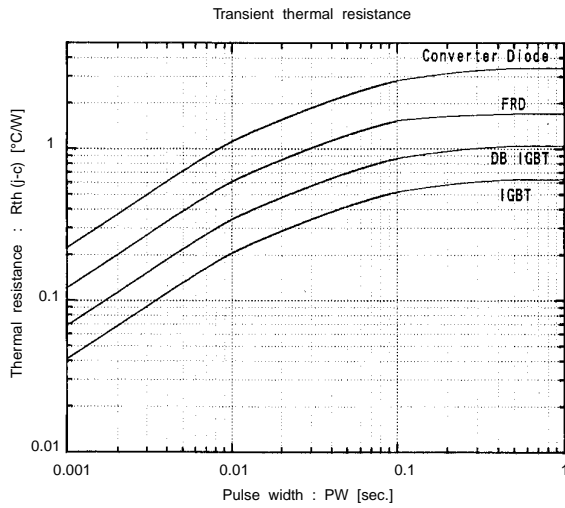
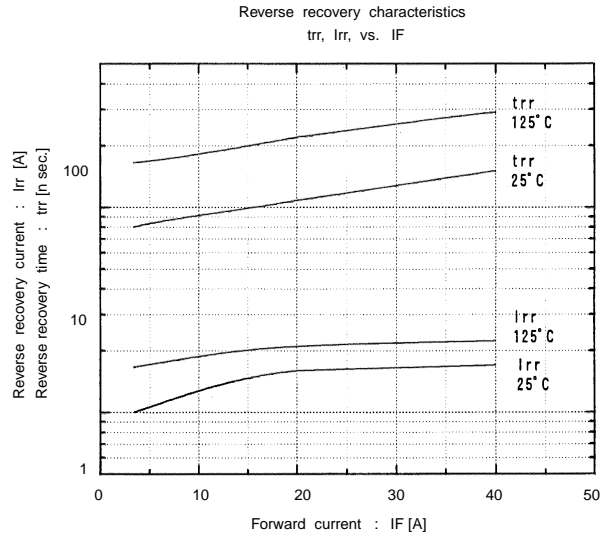
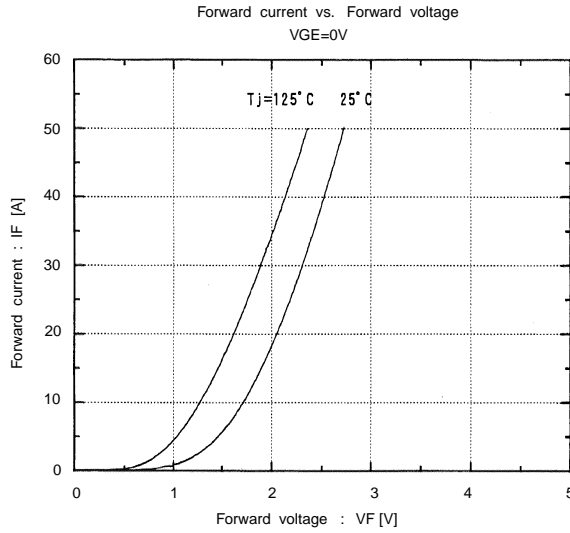
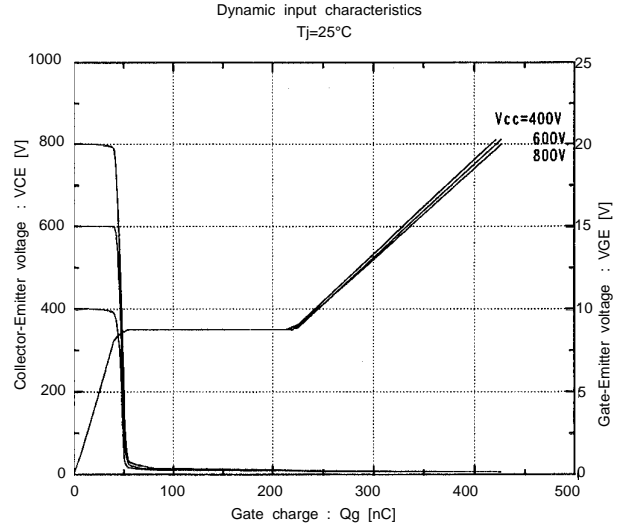
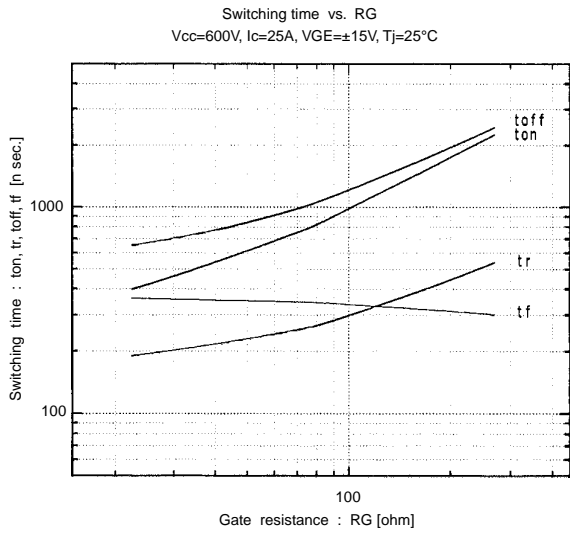

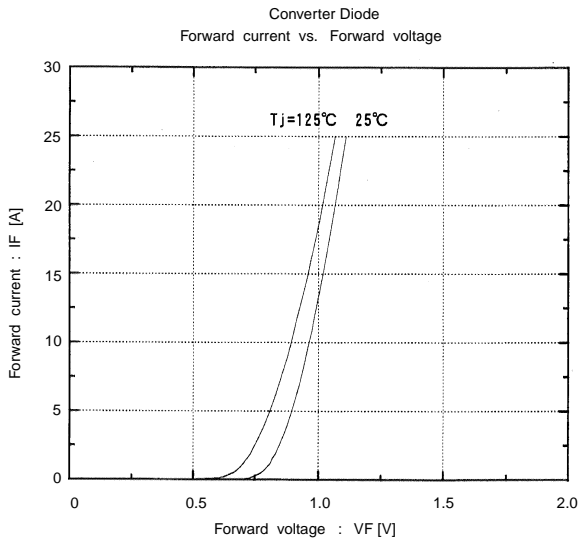
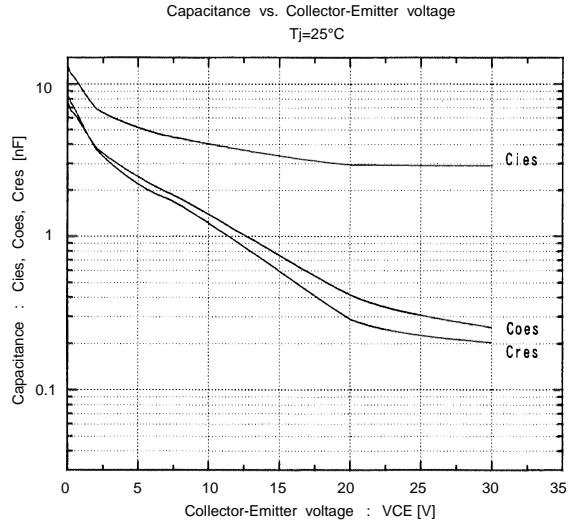
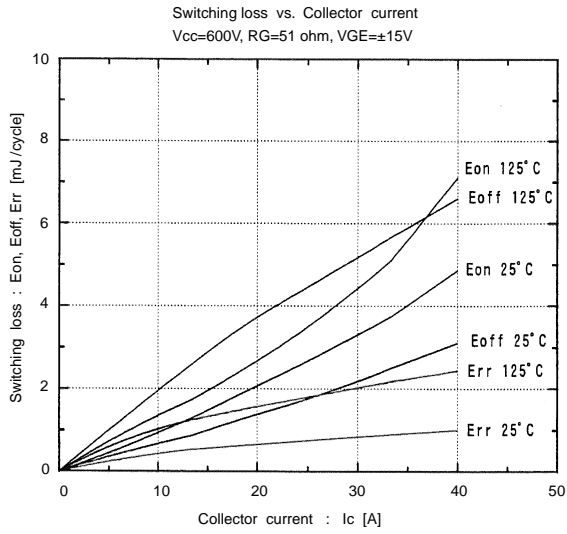

● Brake

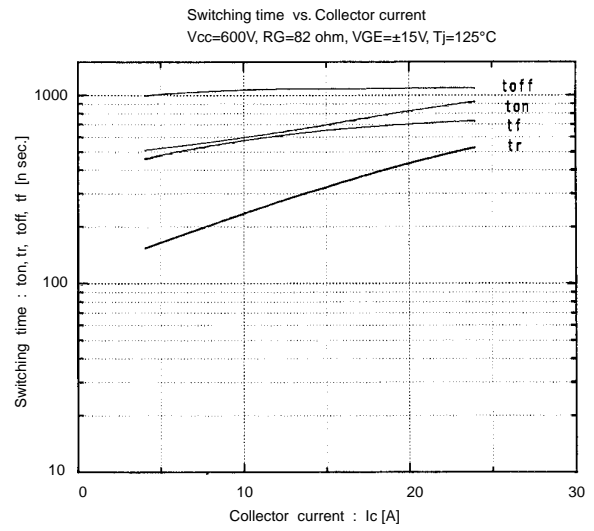
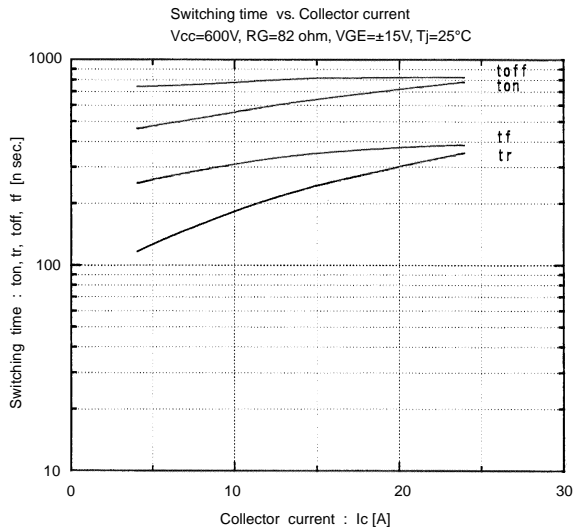
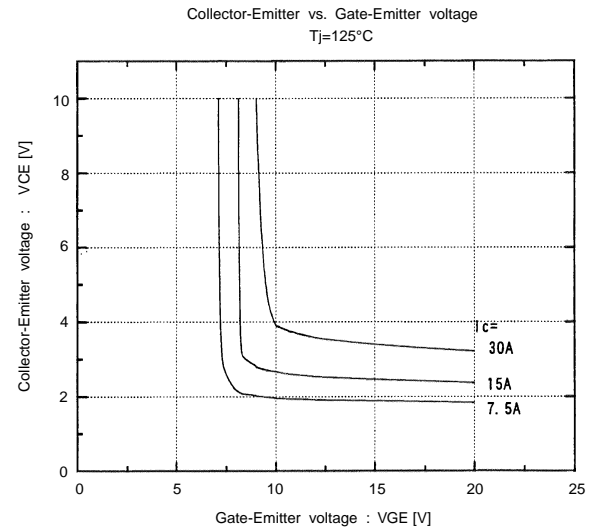
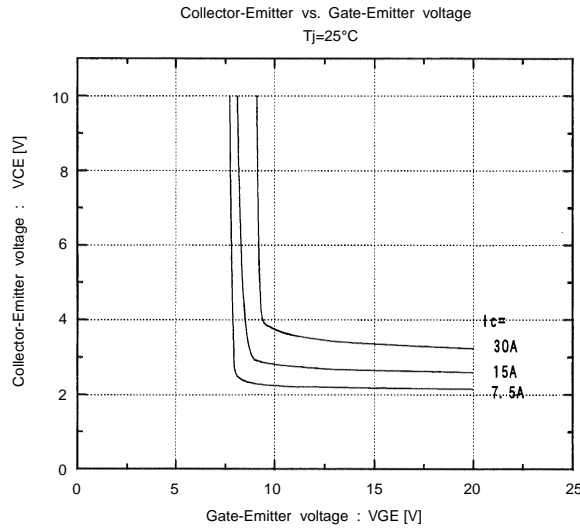
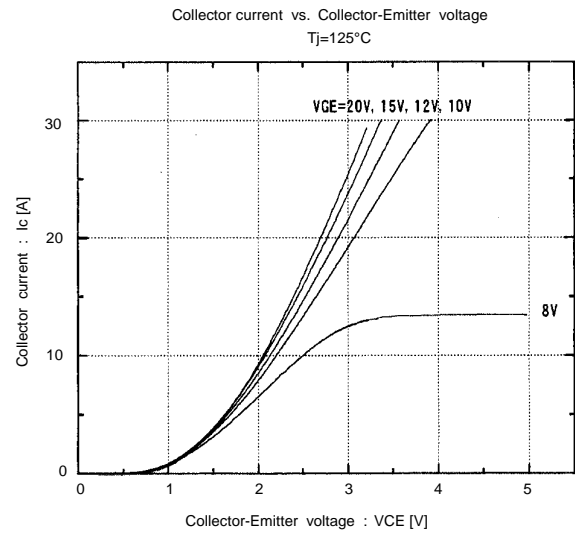
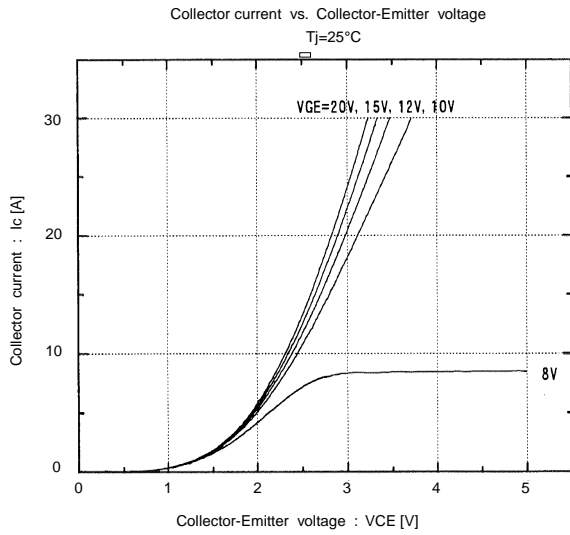

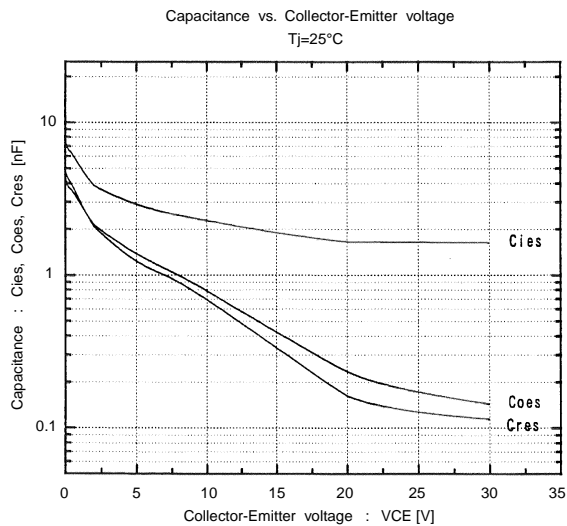
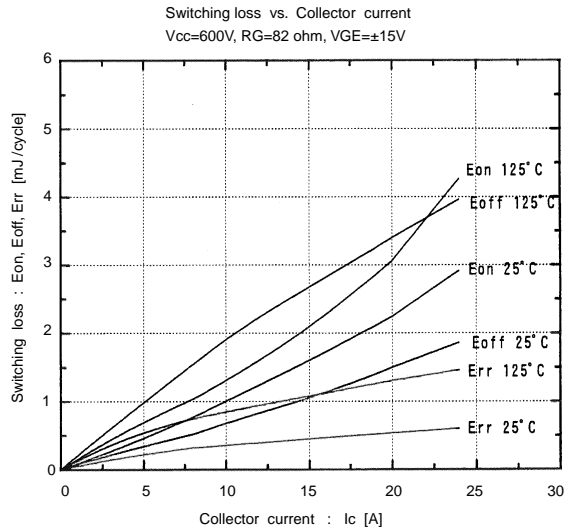
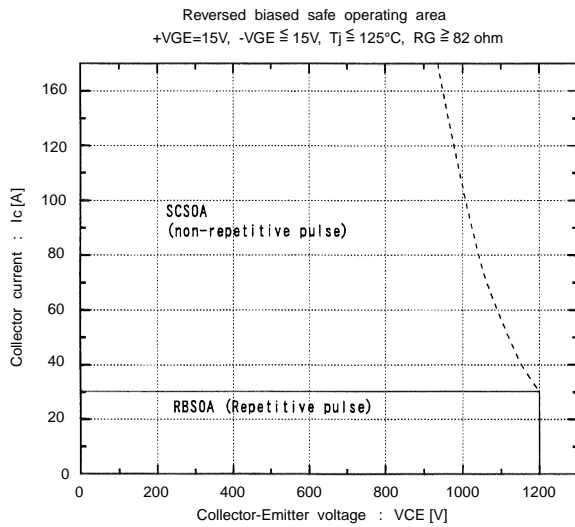
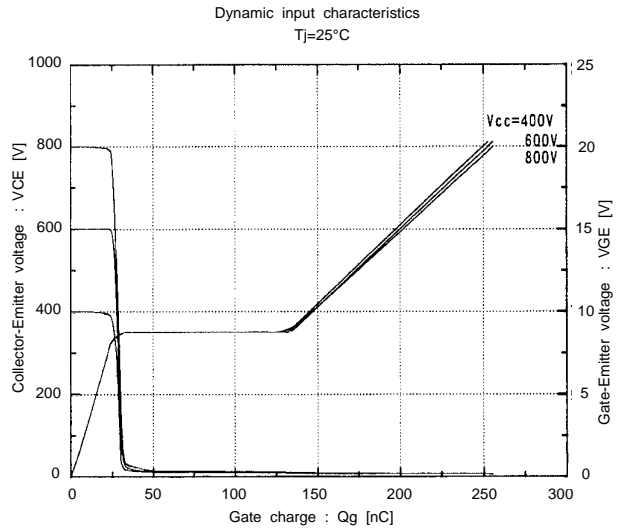
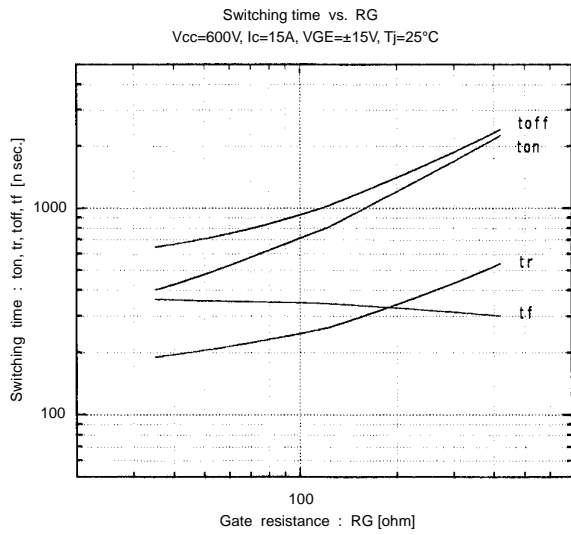

■ Outline Drawings, mm

