

DIODE MODULE (F.R.D.)

FRG25CA120

UL:E76102(M)

FRG25CA120 is a high speed (fast recovery) isolated diode module designed for high power switching application. FRG25CA120 is suitable for high frequency application requiring low loss and high speed control.

- High Speed $t_{rr} \leq 200\text{ns}$
- $I_{F(AV)}$ 25A
- Isolated Mounting base.
- High Surge Capability

(Applications)

Inverter Welding Power Supply
Power Supply for Telecommunication
Various Switching Power Supply.

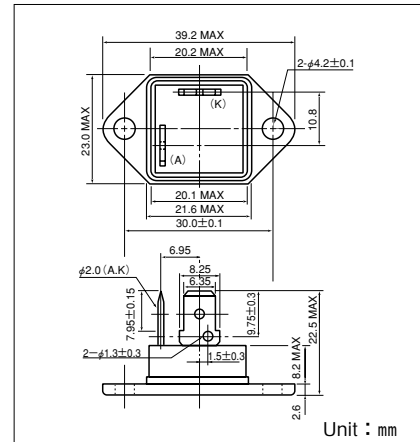
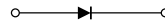

Maximum Ratings

($T_j = 25^\circ\text{C}$ unless otherwise specified)

Symbol	Item	Ratings		Unit
		FRG25CA120		
V_{RRM}	Repetitive Peak Reverse Voltage	1200		V
$V_{R(DC)}$	D.C. Reverse Voltage	960		V

Symbol	Item	Conditions	Ratings	Unit
$I_{F(AV)}$	Forward Current	D.C. $T_c: 78^\circ\text{C}$	25	A
I_{FMS}	Surge Forward Current	$1/2$ cycle, 60Hz, peak value, non-repetitive	400	A
I^2t	I^2t	Value for one cycle surge current	660	A^2S
T_j	Operating Junction Temperature		-40 to +150	$^\circ\text{C}$
T_{stg}	Storage Temperature		-40 to +125	$^\circ\text{C}$
V_{iso}	Isolation Breakdown Voltage (R.M.S.)	A.C. 1 minute	2500	V
	Mounting Torque	Mounting M4	Recommended Value 1.0-1.4 (10-14)	N·m (kgf·cm)
	Mass	Typical Value	23	g

Electrical Characteristics

($T_j = 25^\circ\text{C}$ unless otherwise specified)

Symbol	Item	Conditions	Ratings	Unit
I_{RRM}	Repetitive Peak Reverse Current (max.)	$T_j = 150^\circ\text{C}$ at $V_{RRM} = 1200\text{V}$	1	mA
V_{FM}	Forward Voltage Drop (max.)	$T_j = 25^\circ\text{C}$ $I_F = 25\text{A}$, Inst. measurement	1.80	V
t_{rr}	Reverse Recovery Time (max.)	$I_F = 25\text{A}$, $-di/dt = 100\text{A}/\mu\text{s}$	200	ns
$R_{th(j-c)}$	Thermal Impedance (max.)	Junction to case	1.6	$^\circ\text{C}/\text{W}$

