

TOSHIBA INTEGENT POWER MODULE SILICON N CHANNEL IGBT

MIG30J103HB

HIGH POWER SWITCHING APPLICATIONS

MOTOR CONTROL APPLICATIONS

- Intelligent Power Module that include IGBT drive circuits, overcurrent, undervoltage lockout, and overtemperature protection.
- The Electrodes are Isolated from Case.
- High speed type IGBT : $V_{CE(sat)}=2.7V$ (MAX.)
 $t_{off}=2.0\mu s$ (MAX.)
 $t_{rr}=0.25\mu s$ (MAX.)
- Outline : TOSHIBA 2-99E1A
- Weight : 80g

EQUIVALENT CIRCUIT

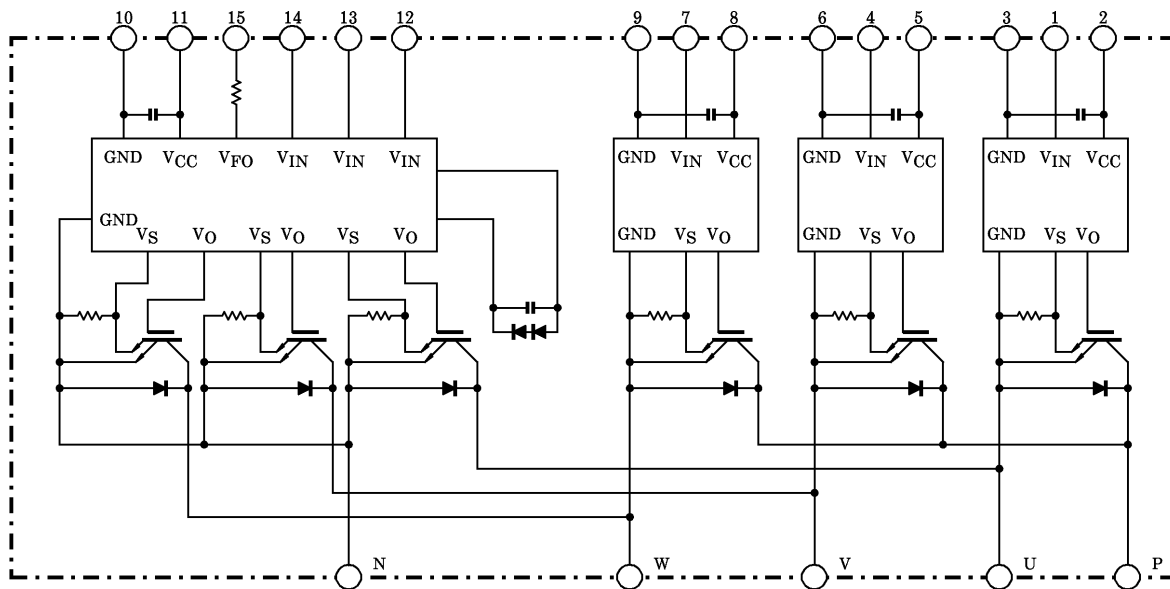

- | | | |
|---------------|---------------|---------------|
| 1. V_{INU} | 2. V_{DU} | 3. GND_U |
| 4. V_{INV} | 5. V_{DV} | 6. GND_V |
| 7. V_{INW} | 8. V_{DW} | 9. GND_W |
| 10. GND_L | 11. V_{DL} | 12. V_{INX} |
| 13. V_{INY} | 14. V_{INZ} | 15. V_{FO} |

961001EAA2

● TOSHIBA is continually working to improve the quality and the reliability of its products. Nevertheless, semiconductor devices in general can malfunction or fail due to their inherent electrical sensitivity and vulnerability to physical stress. It is the responsibility of the buyer, when utilizing TOSHIBA products, to observe standards of safety, and to avoid situations in which a malfunction or failure of a TOSHIBA product could cause loss of human life, bodily injury or damage to property. In developing your designs, please ensure that TOSHIBA products are used within specified operating ranges as set forth in the most recent products specifications. Also, please keep in mind the precautions and conditions set forth in the TOSHIBA Semiconductor Reliability Handbook.

● The information contained herein is presented only as a guide for the applications of our products. No responsibility is assumed by TOSHIBA CORPORATION for any infringements of intellectual property or other rights of the third parties which may result from its use. No license is granted by implication or otherwise under any intellectual property or other rights of TOSHIBA CORPORATION or others.

● The information contained herein is subject to change without notice.

MAXIMUM RATINGS ($T_j = 25^\circ\text{C}$)

	SYMBOL	ITEM	CONDITION	RATING	UNIT
Inverter Part	V_{CC}	Supply Voltage	P-N	400	V
	V_{CES}	Collector-Emitter Voltage	—	600	V
	$\pm I_C$	Collector Current (DC)	$T_c = 25^\circ\text{C}$	30	A
	P_C	Collector Power Dissipation	$T_c = 25^\circ\text{C}$	100	W
	T_j	Junction Temperature	—	150	$^\circ\text{C}$
Control Part	V_D	Supply Voltage	—	20	V
	V_{IN}	Input Voltage	$V_{IN} = V_D$	20	V
	V_{FO}	Foul Output Voltage	$V_{FO} = V_D$	20	V
	I_{FO}	Foul Output Current	—	7	mA
All System	T_c	Operating Temperature	—	$-20 \sim +100$	$^\circ\text{C}$
	T_{stg}	Storage Temperature Range	—	$-40 \sim +125$	$^\circ\text{C}$
	V_{ISO}	Isolation Voltage	AC, 1 min	2500	V_{rms}
	—	Screw Torque	M5	2	N·m

ELECTRICAL CHARACTERISTICS ($T_j = 25^\circ\text{C}$)

Inverter Part

SYMBOL	ITEM	TEST CONDITION	SPEC			UNIT	
			MIN.	TYP.	MAX.		
$V_{CE(sat)}$	Collector-Emitter Saturation Voltage	$V_D = 15\text{V}$ $I_{IN} = 0\text{mA}$	$I_C = 30\text{A}$	—	2.1	2.7	V
			$I_C = 30\text{A}$, $T_j = 125^\circ\text{C}$	—	—	3.0	
V_F	Forward Voltage	$I_F = 30\text{A}$	—	2.0	2.7	V	
t_{on}	Switching Time	$V_{CC} = 300\text{V}$ $I_C = 30\text{A}$ $V_D = 15\text{V}$ $I_{IN} = 1\text{mA} \leftrightarrow 0\text{mA}$ Inductive Load		0.5	1.3	2.0	μs
$t_c(\text{on})$				—	0.3	1.0	
t_{off}				0.5	1.0	2.0	
$t_c(\text{off})$				—	0.5	1.5	
t_{rr}				—	0.15	0.25	
I_{CES}	Collector Cut-off Current	$V_{CE} = 600\text{V}$	$T_j = 25^\circ\text{C}$	—	—	1	mA
			$T_j = 125^\circ\text{C}$	—	—	20	

Note 1 : Switching Time Test Circuit & Timing Chart

a) Low Side Switching

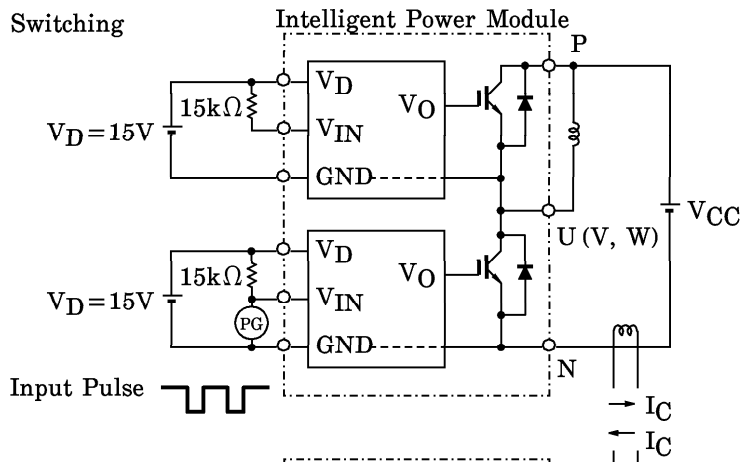

b) High Side Switching

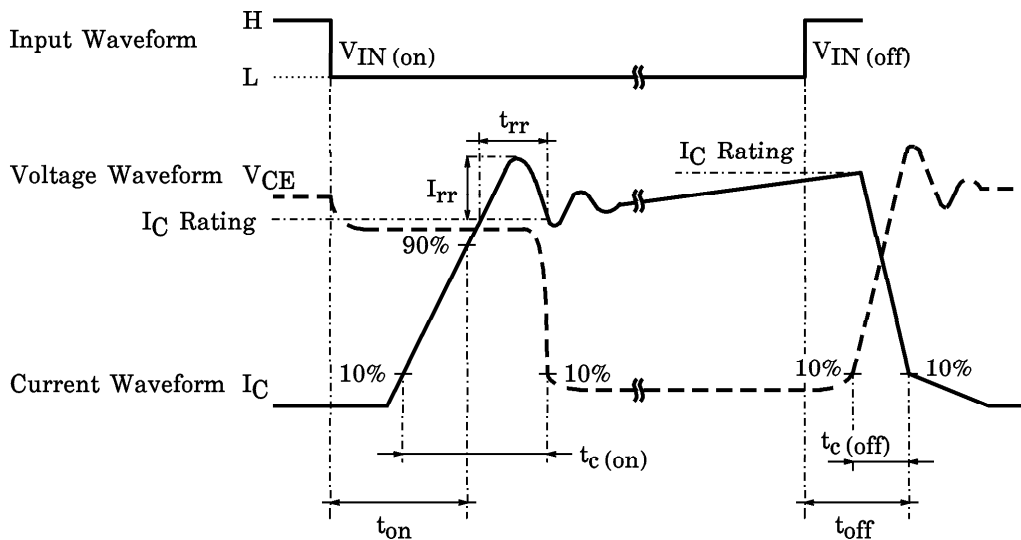
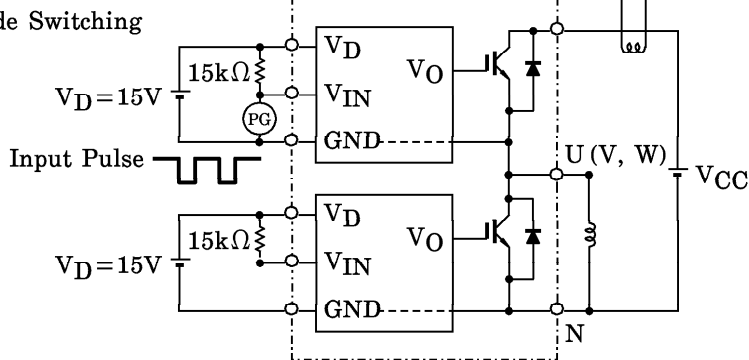

Control Part (T_j = 25°C)

SYMBOL	ITEM	TEST CONDITION	SPEC			UNIT	
			MIN.	TYP.	MAX.		
I _D	Circuit Current	V _D = 15V	High Side	6	12	18	mA
			Low Side	11	23	35	
V _{IN (on)}	Input On Signal Voltage	—	1.0	1.3	1.6	V	
V _{IN (off)}	Input Off Signal Voltage		1.5	1.8	2.1		
I _{FO}	Foul Output Current (Protection)	V _D = 15V, V _{FO} = 15V	3	5	7	mA	
	Foul Output Current (Normal)		—	—	1		
OC	Over Current Protection Trip Level	V _D = 15V	46	55	—	A	
		V _D = 15V, T _j ≤ 125°C	39	—	—		
t _{off (OC)}	Over Current Cut Off Time	V _D = 15V	5	10	18	μs	
OT	Over Temperature Protection	Case Temperature	Trip Level	100	110	120	°C
			Reset Level	80	90	100	
UV	Control Supply Under-Voltage Protection	—	Trip Level	11.3	12.0	12.7	V
UVr			Reset Level	11.8	12.5	13.2	
t _{FO}	Foul Output Pulse Width	V _D = 15V	5	10	15	ms	

Thermal Resistance (T_j = 25°C)

SYMBOL	ITEM	TEST CONDITION	SPEC			UNIT
			MIN.	TYP.	MAX.	
R _{th (j-c)}	Junction to Case Thermal Resistance	INV. IGBT	—	—	1.25	°C / W
R _{th (j-c)}		INV. FWD	—	—	3.75	
R _{th (c-f)}	Case to Fin Thermal Resistance with compound	—	—	0.2	—	

ELECTRICAL CHARACTERISTICS TEST CIRCUIT ($V_{CE(sat)}$, V_F , I_{CES} , I_D , V_{IN} , I_{FO} , t_{FO})

a) $V_{CE(sat)}$

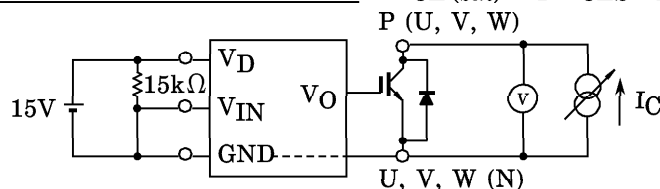

b) V_F

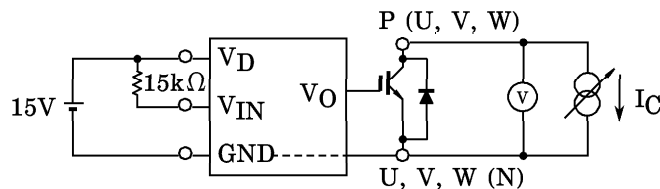

c) I_{CES}

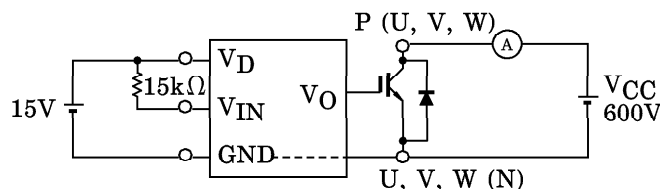

d) I_D

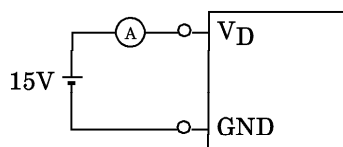

e) $V_{IN(OFF)}$
 $V_{IN(ON)}$

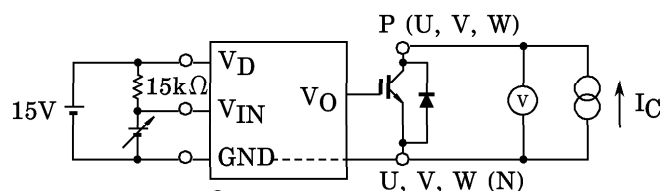

f) t_{FO}

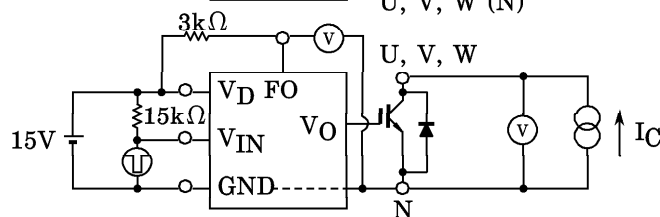

g) I_{FO}

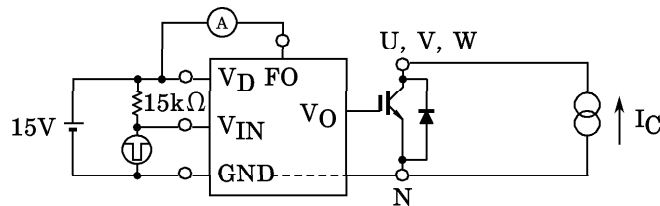

OUTLINE : TOSHIBA 2-99E1A

Unit in mm

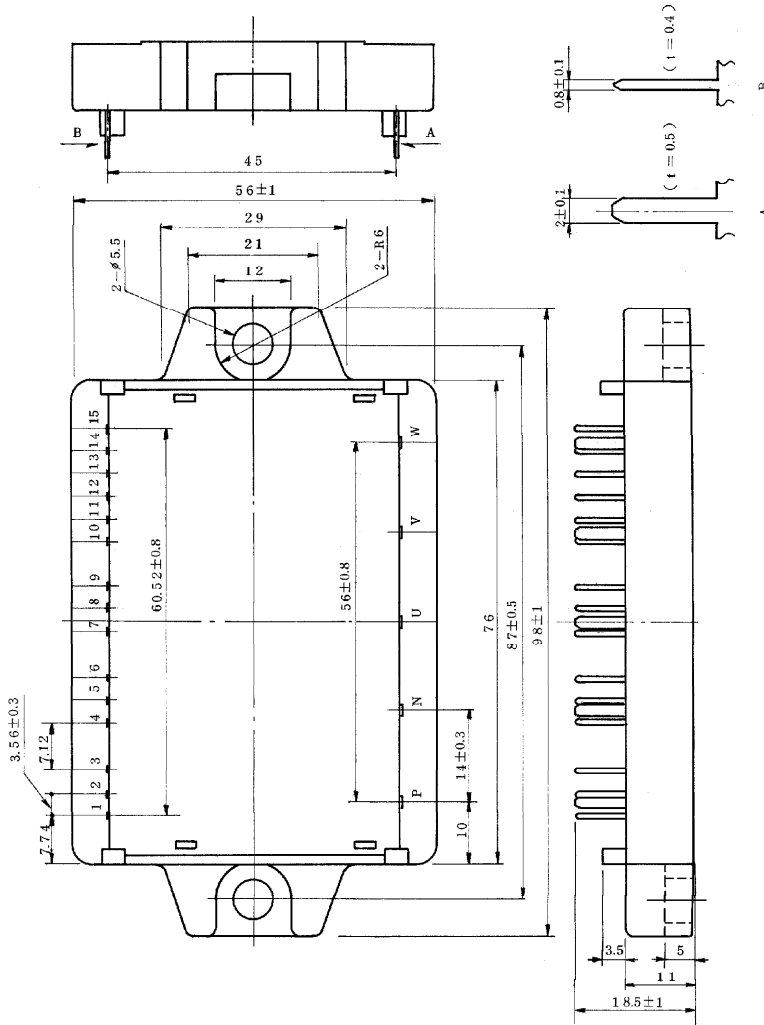

- | | | |
|----------|----------|----------|
| 1. VINU | 2. VDU | 3. GNDU |
| 4. VINV | 5. VDV | 6. GNDV |
| 7. VINW | 8. VDW | 9. GNDW |
| 10. GNDL | 11. VDL | 12. VINX |
| 13. VINY | 14. VINZ | 15. VFO |

TIMING CHART (High side)

Typical example of drive circuit

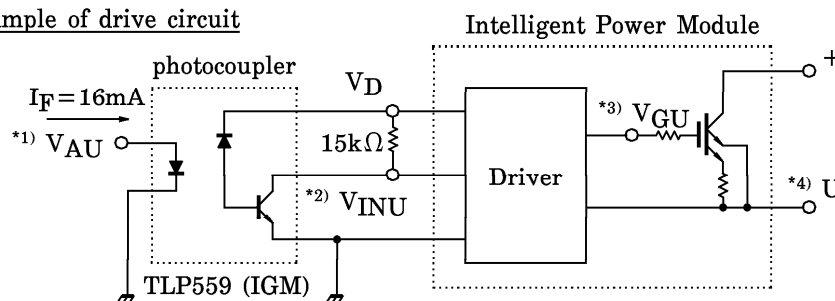

- *1) or V_{AV} , V_{AW}
- *2) or V_{INV} , V_{INW}
- *3) or V_{GV} , V_{GW}
- *4) or V , W

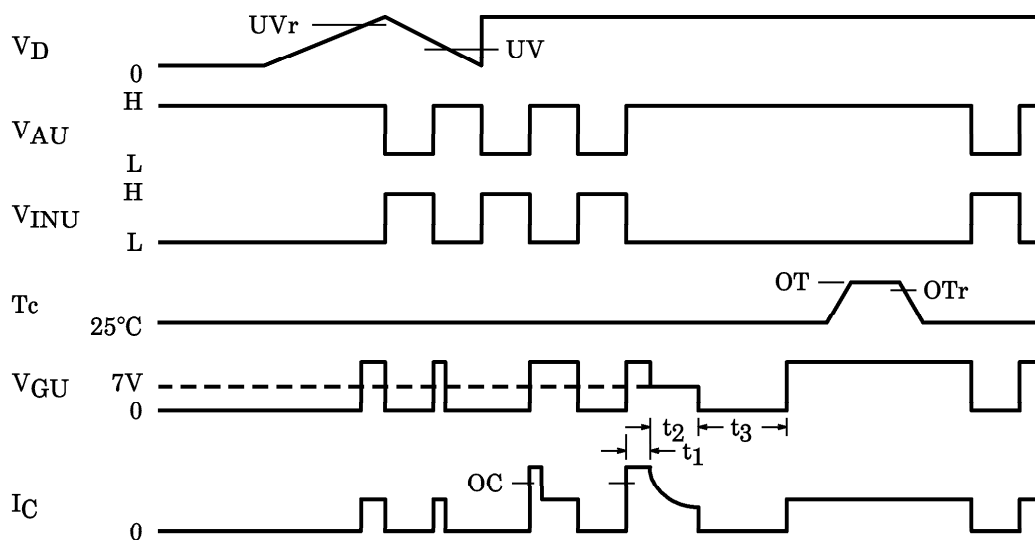

- UV : Under-Voltage Trip Level
- UVr : Under-Voltage Reset Level
- OT : Over Temperature Trip Level
- OTr : Over Temperature Reset Level
- OC : Over Current
- t_1 : $2.5\mu s$ (Typ.)
- t_2 : $10\mu s$ (Typ.)
- t_3 : $10ms$ (Typ.)

TIMING CHART (Low side)

Typical example of drive circuit

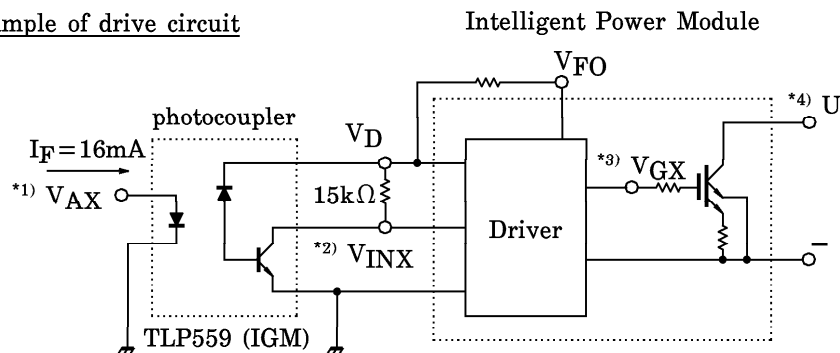

- *1) or VAY, VAZ
- *2) or VINY, VINZ
- *3) or VGY, VGZ
- *4) or V, W

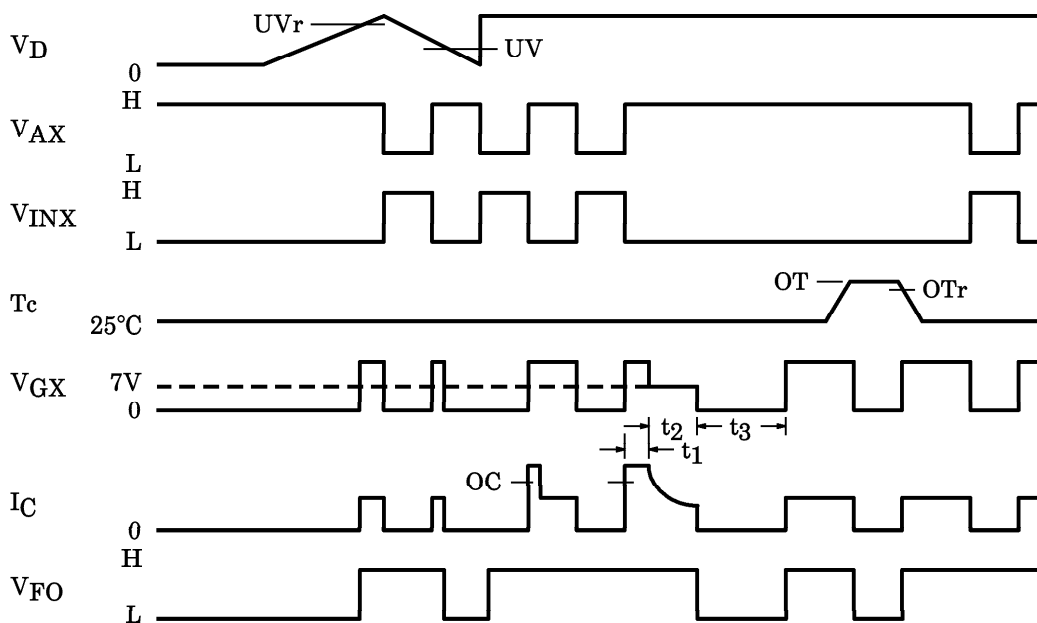

- UV : Under-Voltage Trip Level
- UVr : Under-Voltage Reset Level
- OT : Over Temperature Trip Level
- OTr : Over Temperature Reset Level
- OC : Over Current
- t₁ : 2.5μs (Typ.)
- t₂ : 10μs (Typ.)
- t₃ : 10ms (Typ.)

