

パワートランジスタモジュール POWER TRANSISTOR MODULE

■ 特長 : Features

- hFEが高い High DC Current Gain
- 高速スイッチング High Speed Switching

■ 用途 : Applications

- 汎用インバータ General Purpose Inverter
- 無停電電源装置 Uninterruptible Power Supply
- NC工作機械 Servo & Spindle Drive for NC MachineTools
- ロボット Robotics (Servo Drive for Robots)
- 溶接機等のスイッチング電源
Switching Power Supplies for Welding Machines

■ 定格と特性 Maximum ratings and characteristic

● 絶対最大定格

Absolute maximum ratings (Tc=25°C unless otherwise specified)

Item	Symbol	Rating	Unit
コレクタ・ベース間電圧	V _{CB0}	600	V
コレクタ・エミッタ間電圧	V _{CEO}	600	V
コレクタ・エミッタ間電圧	V _{CEO(SUS)}	450	V
エミッタ・ベース間電圧	V _{EBO}	10	V
コレクタ電流	DC	I _c	30
	1ms	I _{CP}	60
	DC	-I _c	30
ベース電流	DC	I _b	1.8
	1ms	I _{BP}	3.6
コレクタ損失	one Transistor	P _C	200
	six Transistors	P _C	1200
接合部温度	T _j	+150	°C
保存温度	T _{stg}	-40 to +125	°C
質量	m	235	g
絶縁耐圧	AC.1min	Viso	2500
締付けトルク	Mounting *1	2.0	N·m

● 電気的特性 : Electrical characteristics (Tc =25°C unless otherwise specified)

Item	Symbol	Test Conditions	Min.	Typ.	Max.	Units
コレクタ・ベース間電圧	V _{CB0}	I _{CB0} = 1mA	600			V
コレクタ・エミッタ間電圧	V _{CEO}	I _c = 1mA	600			V
コレクタ・エミッタ間電圧	V _{CEO(SUS)}	I _c = 1A	450			V
	V _{CEx(SUS)}					V
エミッタ・ベース間電圧	V _{EBO}	I _{EBO} = 200mA	10			V
コレクタしゃ断電流	I _{CB0}	V _{CB0} = 600V			1.0	mA
エミッタしゃ断電流	I _{EBO}	V _{EBO} = 10V			200	mA
コレクタ・エミッタ間電圧	-V _{CE}	-I _c = 30A			1.8	V
直流電流増幅率	h _{FE}	I _c = 30A, V _{CE} = 2.5V, T _j = 125°C	750			-
コレクタ・エミッタ飽和電圧	V _{CE(Sat)}	I _c = 30A, I _b = 40mA			2.5	V
ベース・エミッタ飽和電圧	V _{BE(Sat)}				3.0	V
スイッチング時間	t _{on}	I _c = 30A			3.0	μs
	t _{stg}	I _{B1} = +40mA			8.0	μs
	t _f	I _{B2} = -0.6A			3.0	μs
逆回復時間	t _{rr}	-I _c = 30A, V _{BE} = -6V, -di/dt = 100A/μs			0.6	

● 熱的特性 : Thermal characteristics

Item	Symbol	Test Conditions	Min.	Typ.	Max.	Units
熱抵抗	R _{th(j-c)}	Transistor			0.625	°C/W
	R _{th(j-c)}	Diode			2.0	°C/W
	R _{th(c-f)}	With Thermal Compound		0.05		°C/W

■ 外形寸法: Outline Drawings

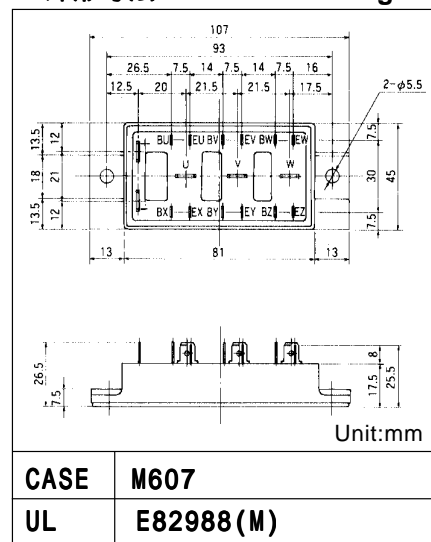

■ 等価回路:

Equivalent Circuit Schematic

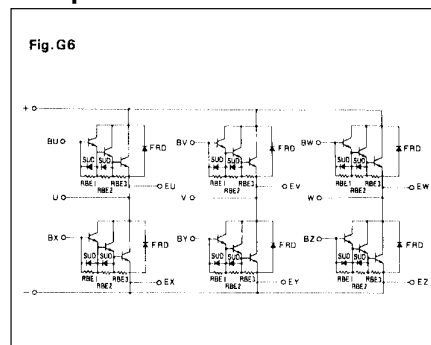

Note:

*1: 推奨値 Recommendable Value;
1.5to2.0N·m [15to20kgf·cm] (M5)

■ 特性曲線 : Characteristics

