



Dual Output A-Series, BWR Models

High-Reliability, 2" x 2"
15-20 Watt, DC/DC Converters

A-SERIES

Features

- Low cost! Highly reliable!
- Proven SMT-on-pcb construction
- Qual tested; HALT tested; EMC tested
- Designed to meet UL/ EN60950, BASIC insulation (48V_{IN} models)
-  mark available (48V_{IN} models)
- Output voltages: ± 5 , ± 12 or ± 15 Volts
- Ultra-wide input voltage ranges:
4.7-7.5V, 9-36V or 18-75V
- Small packages, 2" x 2" x 0.45"
- Industry-standard pinouts
- Fully isolated, 1500Vdc guaranteed
- Guaranteed efficiencies to 82%
- -40 to +100°C operating temperature
- Modifications and customs for OEM's

For your mid-range power requirements, it's hard to beat the combination of low cost, proven reliability and outstanding electrical performance offered by the 15-20W, dual-output models of DATEL's new A-Series DC/DC converters. These highly efficient, rugged converters combine straightforward circuit topologies, the newest components, proven SMT-on-pcb construction methods, and highly repeatable automatic-assembly techniques. Their superior durability is substantiated by a rigorous in-house qualification program that includes HALT (Highly Accelerated Life Testing).

The ultra-wide input voltage ranges of the A-Series duals (4.7-7.5V for "D5A" models, 9-36V for "D12A" models and 18-75V for "D48A" models) make them excellent candidates for battery-powered systems or for distributed power architectures. Their ± 5 , ± 12 or ± 15 Volt outputs cover virtually all standard applications.

These popular power converters are fully isolated (1500Vdc guaranteed) and display excellent line and load regulation (with specs as low as $\pm 0.3\%$ max. for line and $\pm 0.5\%$ max. for load). They are completely I/O protected (input overvoltage shutdown and reverse-polarity protection, output current limiting and overvoltage protection) and contain input (pi type) and output filtering to reduce noise. They require no external components and offer true "plug-and-play" convenience.

These extremely reliable, cost-effective power converters are housed in standard 2" x 2" x 0.45" metal packages coated with electrically non-conductive materials. They offer industry-standard pinouts and are ideally suited for high-volume computer, telecom/datacom, instrumentation and ATE applications.

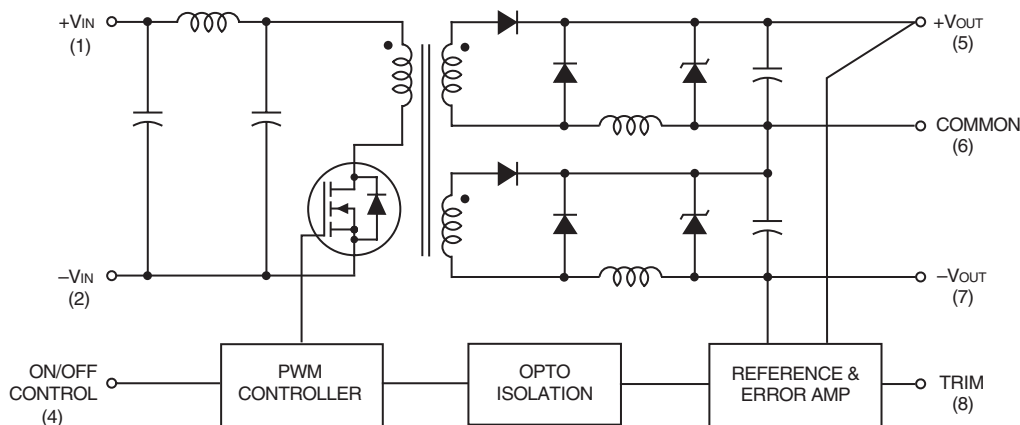

Figure 1. Simplified Schematic

Performance Specifications and Ordering Guide ①

Model	Output				Input			Efficiency		Package (Case, Pinout)		
	V _{OUT} (Volts)	I _{OUT} (mA)	R/N (mVp-p) ②		Regulation (Max.)		V _{IN} Nom. (Volts)	Range (Volts)	I _{IN} ④ (mA)		Min.	Typ.
			Typ.	Max.	Line	Load ③						
BWR-5/1500-D5A	±5	±1500	50	100	±0.5%	±1.0%	5	4.7-7.5	75/3750	79%	80%	C4, P7
BWR-5/1700-D12A	±5	±1700	75	100	±0.3%	±0.5%	24	9-36	15/753	80.5%	83%	C4, P7
BWR-5/1700-D48A	±5	±1700	75	100	±0.3%	±0.5%	48	18-75	15/377	81%	83%	C4, P7
BWR-12/625-D5A	±12	±625	75	120	±0.5%	±1.0%	5	4.7-7.5	75/3750	79%	81%	C4, P7
BWR-12/830-D12A	±12	±830	75	100	±0.3%	±0.5%	24	9-36	30/1000	81.5%	83%	C4, P7
BWR-12/830-D48A	±12	±830	75	100	±0.4%	±0.5%	48	18-75	15/510	81%	83%	C4, P7
BWR-15/500-D5A	±15	±500	75	150	±0.5%	±1.0%	5	4.7-7.5	75/3659	80%	82%	C4, P7
BWR-15/670-D12A	±15	±670	75	100	±0.3%	±0.5%	24	9-36	30/979	82%	83%	C4, P7
BWR-15/670-D48A	±15	±670	75	100	±0.3%	±0.5%	48	18-75	15/484	82%	84%	C4, P7

- ① Typical at T_A = +25°C under nominal line voltage and full-load conditions unless otherwise noted.
- ② Ripple/Noise (R/N) measured over a 20MHz bandwidth.
- ③ Balanced loads, 20% to 100% load.
- ④ Nominal line voltage, no-load/full-load conditions.

PART NUMBER STRUCTURE

B WR 12 / 830 - D48 A

Output Configuration:
B = Bipolar

Wide Range Input

Nominal Output Voltages:
±5, ±12 or ±15 Volts

A-Series
High Reliability

Input Voltage Range:
D5 = 4.7-7.5 Volts (5V nominal)
D12 = 9-36 Volts (24V nominal)
D48 = 18-75 Volts (48V nominal)

Maximum Output Current
in mA from each output

TEMPERATURE DERATING

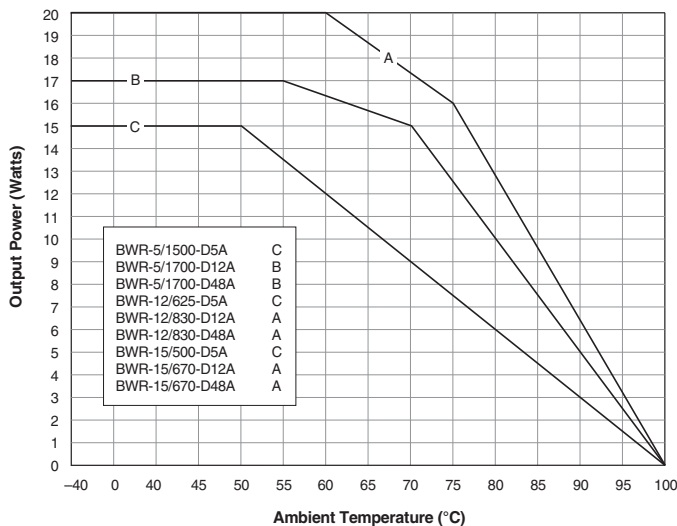

MECHANICAL SPECIFICATIONS

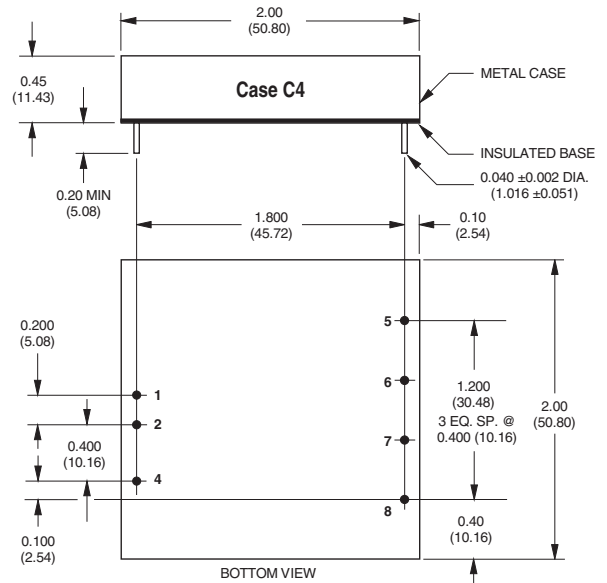

DIMENSIONS ARE IN INCHES (MM)

I/O Connections	
Pin	Function P7
1	+Input
2	-Input
3	No Pin
4	On/Off Control
5	+Output
6	Common
7	-Output
8	Trim

Notes:

For "D5A" and "D12A" models, the case is connected to pin 2 (-V_{IN}).

For "D48A" models, the case is connected to pin 1 (+V_{IN}).

Performance/Functional Specifications

Typical @ T_A = +25°C under nominal line voltage and full-load conditions, unless noted. ①

Input	
Input Voltage Range:	
D5A Models	4.7-7.5 Volts (5V nominal)
D12A Models	9-36 Volts (24V nominal)
D48A Models	18-75 Volts (48V nominal)
Input Current	See Ordering Guide
Input Filter Type ②	Pi
Overvoltage Shutdown:	
D5A Models	10 Volts
D12A Models	40 Volts
D48A Models	80 Volts
Reverse-Polarity Protection	Yes (Instantaneous, 10A maximum)
On/Off (Sync.) Control (Pin 4) ③	TTL high = off, low (or open) = on
Output	
V_{out} Accuracy (50% load):	
±5V Outputs	±1.5%, maximum
±9/12/15V Outputs	±1%, maximum
Temperature Coefficient	±0.02% per °C
Ripple/Noise (20MHz BW) ②	See Ordering Guide
Line/Load Regulation	See Ordering Guide
Efficiency	See Ordering Guide
Isolation Voltage ④	1500Vdc, minimum
Isolation Capacitance	550pF
Current Limiting	Auto-recovery
Overvoltage Protection	Zener/transorb clamps, magnetic feedback
Dynamic Characteristics	
Transient Response (50% load step)	200µsec max. to ±1.5% of final value
Switching Frequency	165kHz (±15kHz)
Environmental	
Operating Temperature (ambient):	
Without Derating	-40 to +50/55/60°C (Model dependent)
With Derating	to +100°C (See Derating Curves)
Storage Temperature	-40 to +105°C
Physical	
Dimensions	2" x 2" x 0.45" (51 x 51 x 11.4mm)
Shielding	5-sided
Case Connection:	
D5A and D12A Models	Pin 2 (-V _{IN})
D48A Models	Pin 1 (+V _{IN})
Case Material	Corrosion resistant steel with non-conductive, epoxy-based, black enamel finish and plastic baseplate
Pin Material	Brass, solder coated
Weight	2.7 ounces (75.6 grams)

- ① These converters require a minimum 20% loading on each output to maintain specified regulation. Operation under no-load conditions will not damage these devices; however they may not meet all listed specifications.
- ② Application-specific internal input/output filtering can be recommended and perhaps added internally upon request. Contact DATEL Applications Engineering for details.
- ③ Applying a voltage to the Control pin when no input power is applied to the converter can cause permanent damage to the converter.
- ④ "D48A" models have BASIC, "D5A" and "D12A" models have Functional insulation. Devices can be screened or modified for higher guaranteed isolation voltages. Contact DATEL Applications Engineering for details.

Absolute Maximum Ratings

Input Voltage:	
D5A Models	12 Volts
D12A Models	44 Volts
D48A Models	88 Volts
Input Reverse-Polarity Protection	Current must be <10A. Brief duration only. Fusing recommended.
Output Overvoltage Protection	
±5V Outputs	6.8 Volts, limited duration
±12V Outputs	15 Volts, limited duration
±15V Outputs	18 Volts, limited duration
Output Current	Current limited. Max. current and short-circuit duration are model dependent.
Storage Temperature	-40 to +105°C
Lead Temperature (soldering, 10 sec.)	+300°C

These are stress ratings. Exposure of devices to any of these conditions may adversely affect long-term reliability. Proper operation under conditions other than those listed in the Performance/Functional Specifications Table is not implied.

TECHNICAL NOTES

Floating Outputs

Since these are isolated DC/DC converters, their outputs are "floating." Any BWR model may be configured to produce an output of 10V, 24V or 30V (for ±5V, ±12V or ±15V models, respectively) by applying the load across the +Output and -Output pins (pins 5 and 7), with either output grounded. The Common pin (pin 6) should be left open. Minimum 20% loading is recommended under these conditions. The total output voltage span may be externally trimmed as described below.

Filtering and Noise Reduction

All A-Series BWR 15-20 Watt DC/DC Converters achieve their rated ripple and noise specifications without the use of external input/output capacitors. In critical applications, input/output ripple and noise may be further reduced by installing electrolytic capacitors across the input terminals and/or low-ESR tantalum or electrolytic capacitors across the output terminals. Output capacitors should be connected between their respective output pin (pin 5 or 7) and Common (pin 6) as shown in Figure 2. The caps should be located as close to the power converters as possible. Typical values are listed in the tables below. In many applications, using values greater than those listed will yield better results.

To Reduce Input Ripple

D5A Models	47µF, 16V
D12A Models	20µF, 50V
D48A Models	20µF, 100V

To Reduce Output Ripple

±5V Outputs	47µF, 10V, Low ESR
±9/12/15V Outputs	22µF, 20V, Low ESR

In critical, space-sensitive applications, DATEL may be able to tailor the internal input/output filtering of these units to meet your specific requirements. Contact our Applications Engineering Group for additional details.

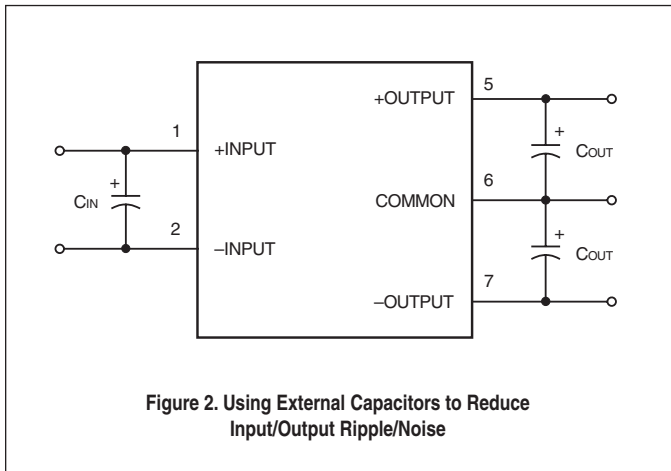

Figure 2. Using External Capacitors to Reduce Input/Output Ripple/Noise

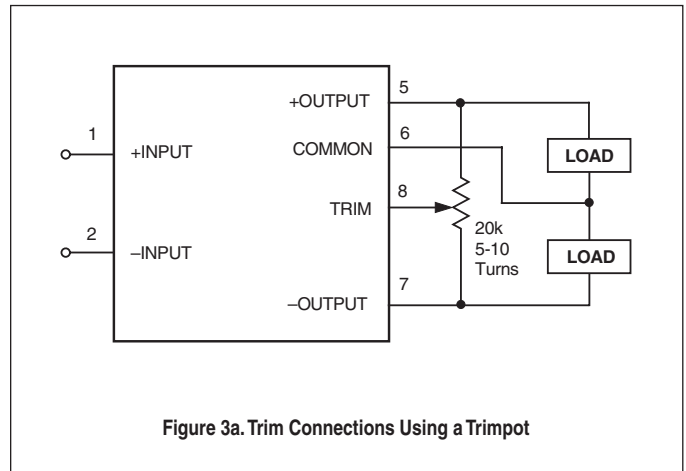

Figure 3a. Trim Connections Using a Trimpot

Input Fusing

Certain applications and/or safety agencies may require the installation of fuses at the inputs of power conversion components. For DATEL A-Series BWR 15-20 Watt DC/DC Converters, you should use slow-blow type fuses with values no greater than the following:

V _{IN} Range	Fuse Value
D5A	6A
D12A	4A
D48A	2A

On/Off Control

The On/Off Control pin (pin 4) may be used for remote on/off operation. A TTL logic high (+2 to +5 Volts, 250µA max.) applied to pin 4 disables the converter. A TTL logic low (0 to +0.8 Volts, 70µA max.), or no connection, enables the converter. Control voltages should be referenced to pin 2 (-Input). Applying a voltage to the Control pin when no input power is applied to the converter can cause permanent damage to the converter.

Synchronization

In critical applications employing multiple switching DC/DC converters, it may be desirable to intentionally synchronize the switching of selected converters (so the system noise can be reduced with notch filtering) or to purposely desynchronize the converters (to lessen the current-carrying requirements on intermediate dc buses). For multiple A-Series Converters, an external clock can be applied to pin 4 (Control) of each device. It should be a square wave with a maximum 1µsec "high" duration and an amplitude between +2V and +5V (see On/Off Control) referenced to pin 2 (-Input). The frequency of the synchronizing clock should be higher than that of any individual converter. Therefore, it should be 185kHz ±5kHz.

Output Trimming

The total output voltage span, from +Output (pin 5) to -Output (pin 7) may be trimmed ±5% via a single external trimpot or fixed resistor. The trimpot should be connected as shown in Figure 3a with its wiper connected to pin 8 (Trim). A trimpot can be used to determine the value of a single fixed resistor which should be connected as shown in Figures 3b and 3c. Connect the resistor between pin 8 (Trim) and pin 5 (+Output) to trim "down" the output voltages. Connect the resistor between pins 8 and 7 (-Output) to trim "up" the output voltages. Fixed resistors should be metal-film types with absolute TCR's less than 100ppm/°C to ensure stability.

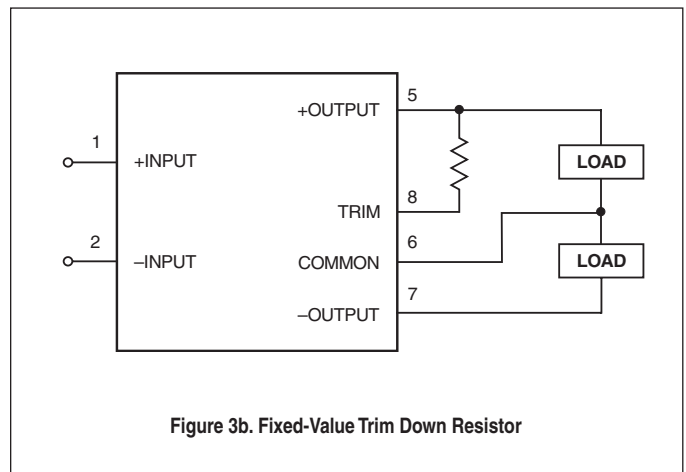

Figure 3b. Fixed-Value Trim Down Resistor

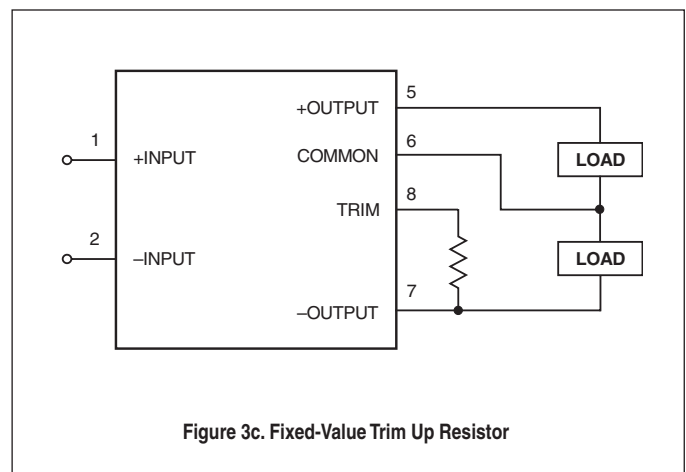

Figure 3c. Fixed-Value Trim Up Resistor

CUSTOM CAPABILITIES

DATEL's world-class design, development and manufacturing team stands ready to work with you to deliver the exact power converter you need for your demanding, large volume, OEM applications. And ... we'll do it on time and within budget!

Our experienced applications and design staffs; quick-turn prototype capability; highly automated, SMT assembly facilities; and in-line SPC quality-control techniques combine to give us the unique ability to design and deliver any quantity of power converters to the highest standards of quality and reliability.

We have compiled a large library of DC/DC designs that are currently used in a variety of telecom, medical, computer, railway, aerospace and industrial applications. We may already have the converter you need.

Contact us. Our goal is to provide you the highest-quality, most cost-effective

EMI RADIATED EMISSIONS

If you're designing with EMC in mind, please note that all of DATEL's BWR 15-20 Watt A-Series DC/DC Converters have been characterized for radiated and conducted emissions in our new EMI/EMC laboratory. Testing is conducted in an EMCO 5305 GTEM test cell utilizing EMCO automated EMC test software. Radiated emissions are tested to the limits of FCC Part 15, Class B and CISPR 22 (EN 55022), Class B. Correlation to other specifications can be supplied upon request. Radiated emissions plots to FCC and CISPR 22 for model BWR-5/1700-D48A appear below. Published EMC test reports are available for each model number. Contact DATEL's Applications Engineering Department for more details.

**BWR-5/1700-D48A Radiated Emissions
FCC Part 15 Class B, 3 Meters
Converter Output = $\pm 5V_{dc}$ @ $\pm 1.6A$**

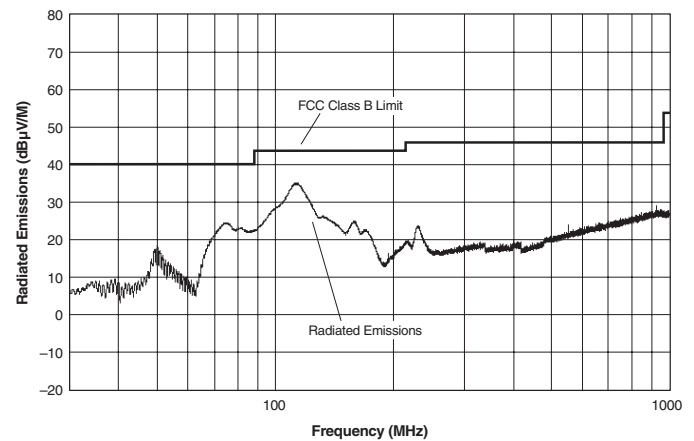

**BWR-5/1700-D48A Radiated Emissions
EN 55022 Class B, 10 Meters
Converter Output = $\pm 5V_{dc}$ @ $\pm 1.6A$**

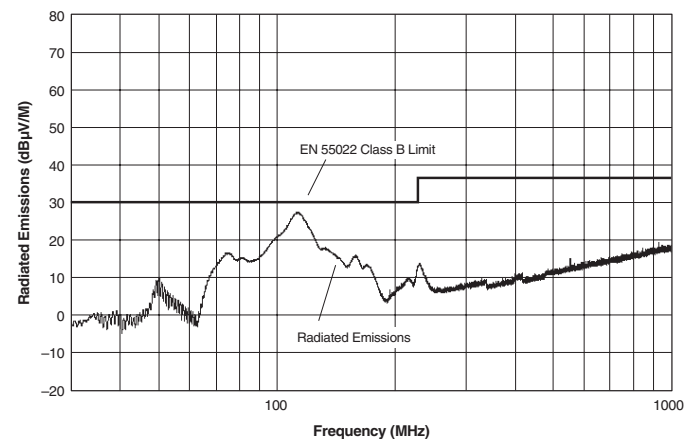

Quality and Reliability

The A-Series are the first DC/DC Converters to emerge from DATEL's new, company-wide approach to designing and manufacturing the most reliable power converters available. The five-pronged program draws our Quality Assurance function into all aspects of new-product design, development, characterization, qualification and manufacturing.

Design for Reliability

Design for Reliability is woven throughout our multi-phased, new-product-development process. Design-for-reliability practices are fully documented and begin early in the new-product development cycle with the following goals:

1. To work from an approved components/vendors list ensuring the use of reliable components and the rigorous qualification of new components.
2. To design with safety margins by adhering to a strict set of derating guidelines and performing theoretical worst-case analyses.
3. To locate potential design weaknesses early in the product-development cycle by using extensive HALT (Highly Accelerated Life Testing).
4. To prove that early design improvements are effective by employing a thorough FRACA (Failure Reporting Analysis and Corrective Action) system.

HALT Testing

The goal of the accelerated-stress techniques used by DATEL is to force device maturity, in a short period of time, by exposing devices to excessive levels of "every stimulus of potential value." We use HALT (Highly Accelerated Life Testing) repeatedly during the design and early manufacturing phases to detect potential electrical and mechanical design weaknesses that could result in possible future field failures.

During HALT, prototype and pre-production DC/DC converters are subjected to progressively higher stress levels induced by thermal cycling, rate of temperature change, vibration, power cycling, product-specific stresses (such as dc voltage variation) and combined environments. The stresses are not meant to simulate field environments but to expose any weaknesses in a product's electro/mechanical design and/or assembly processes. The goal of HALT is to make products fail so that device weaknesses can be analyzed and strengthened as appropriate. Applied stresses are continually stepped

Typical HALT Profile

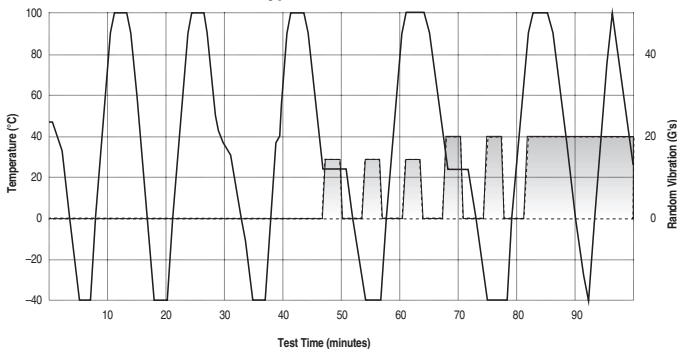

up until products eventually fail. After corrective actions and/or design changes, stresses are stepped up again and the cycle is repeated until the "fundamental limit of the technology" is determined.

DATEL has invested in a Qualmark OVS-1 HALT tester capable of applying voltage and temperature extremes as well as 6-axis, linear and rotational, random vibration. A typical HALT profile (shown above) consists of thermal cycling (-55 to +125°C, 30°C/minute) and simultaneous, gradually increasing, random longitudinal and rotational vibration up to 20G's with load cycling and applied-voltage extremes added as desired. Many devices in DATEL's new A-Series could not be made to fail prior to reaching either the limits of the HALT chamber or some previously known physical limit of the device. We also use the HALT chamber and its ability to rapidly cool devices to verify their "cold-start" capabilities.

Qualification

For each new product, electrical performance is verified via a comprehensive characterization process and long-term reliability is confirmed via a rigorous qualification procedure. The qual procedure includes such strenuous tests as thermal shock and 500 hour life. Qual testing is summarized below.

Qualification Testing

Qualification Test	Method/Comments
HALT	DATEL in-house procedure
High Temperature Storage	Max. rated temp., 1,000 hours
Thermal Shock	10 cycles, -55 to +125°C
Temperature/Humidity	+85°C, 85% humidity, 48 hours
Lead Integrity	DATEL in-house procedure
Life Test	+70°C, 500 hours*
Marking Permanency	DATEL in-house procedure
End Point Electrical Tests	Per product specification

* Interim electrical test at 200 hours.

In-Line Process Controls and Screening

A combination of statistical sampling and 100% inspection techniques keeps our assembly line under constant control. Parameters such as solder-paste thickness, component placement, cleanliness, etc. are statistically sampled, charted and fine tuned as necessary. Visual inspections are performed by trained operators after pick-and-place, soldering and cleaning operations. Units are 100% electrically tested prior to potting. All devices are temperature cycled, burned-in, hi-pot tested and final-electrical tested prior to external visual examination, packing and shipping.

Rapid Response to Problems

DATEL employs an outstanding corrective-action system to immediately address any detected shortcomings in either products or processes. Whenever our assembly, quality or engineering personnel spot a product/process problem, or if a product is returned with a potential defect, we immediately perform a detailed failure analysis and, if necessary, undertake corrective actions. Over time, this system has helped refine our assembly operation to yield one of the lowest product defect rates in the industry.



ISO 9001 REGISTERED

DS-0323A 8/02

DATEL, Inc. 11 Cabot Boulevard, Mansfield, MA 02048-1151
 Tel: (508) 339-3000 (800) 233-2765 Fax: (508) 339-6356
 Internet: www.datel.com Email: sales@datel.com

DATEL (UK) LTD. Tadley, England Tel: (01256)-880444
 DATEL S.A.R.L. Montigny Le Bretonneux, France Tel: 01-34-60-01-01
 DATEL GmbH München, Germany Tel: 89-544334-0
 DATEL KK Tokyo, Japan Tel: 3-3779-1031, Osaka Tel: 6-6354-2025

DATEL makes no representation that the use of its products in the circuits described herein, or the use of other technical information contained herein, will not infringe upon existing or future patent rights. The descriptions contained herein do not imply the granting of licenses to make, use, or sell equipment constructed in accordance therewith. Specifications are subject to change without notice. The DATEL logo is a registered DATEL, Inc. trademark.