

# SKB 60



**SEMIPONT® 2**

## Power Bridge Rectifiers

**SKB 60**

### Features

- Robust plastic case with screw terminals
- Large, isolated base plate
- Blocking voltage to 1600 V
- High surge currents
- Single phase bridge rectifier
- Easy chassis mounting
- UL recognized, file no. E 63 532

### Typical Applications

- Single phase rectifiers for power supplies
- Input rectifiers for variable frequency drives
- Rectifiers for DC motor field supplies
- Battery charger rectifiers

1) Painted metal sheet of minimum 250 x 250 x 1 mm:  $R_{th(th(c-a))} = 1,8 \text{ K/W}$

$V_{RSM}$ V	$V_{RRM}, V_{DRM}$ V	$I_D = 60 \text{ A}$ (full conduction) ( $T_c = 88 \text{ °C}$ )
400	400	SKB 60/04
800	800	SKB 60/08
1200	1200	SKB 60/12
1400	1400	SKB 60/14
1600	1600	SKB 60/16

Symbol	Conditions	Values	Units
$I_D$	$T_c = 85 \text{ °C}$	67	A
	inductive load		A
	$T_a = 45 \text{ °C}$ , chassis 1)	20	A
	$T_a = 45 \text{ °C}$ ; P13A/125 (P1A/120)	25 (44)	A
	$T_a = 35 \text{ °C}$ , P1A/200F	88	A
$I_{FSM}$	$T_{vj} = 25 \text{ °C}$ ; 10 ms	1000	A
	$T_{vj} = 125 \text{ °C}$ ; 10 ms	850	A
$i^2t$	$T_{vj} = 25 \text{ °C}$ ; 8,3 ... 10 ms	5000	A <sup>2</sup> s
	$T_{vj} = 125 \text{ °C}$ ; 8,3 ... 10 ms	3600	A <sup>2</sup> s
$V_F$	$T_{vj} = 25 \text{ °C}$ ; $I_F = 150 \text{ A}$	max. 1,6	V
$V_{(TO)}$	$T_{vj} = 125 \text{ °C}$	max. 0,85	V
$r_T$	$T_{vj} = 125 \text{ °C}$	max. 5	mΩ
$I_{RD}$	$T_{vj} = 25 \text{ °C}$ ; $V_{DD} = V_{DRM}$ ; $V_{RD} = V_{RRM}$	max. 0,5	mA
	$T_{vj} = 125 \text{ °C}$ ; $V_{RD} = V_{RRM}$	2	mA
$R_{th(j-c)}$	per diode	1	K/W
	total	0,25	K/W
$R_{th(c-s)}$	total	0,05	K/W
$T_{vj}$		- 40 ... + 125	°C
$T_{stg}$		- 40 ... + 125	°C
$V_{isol}$	a. c. 50 Hz; r.m.s.; 1 s / 1 min.	3600 ( 3000 )	V
$M_s$	to heatsink	5 ± 15 %	Nm
$M_t$	to terminals	5 ± 15 %	Nm
$m$		165	g
Case		G 17	

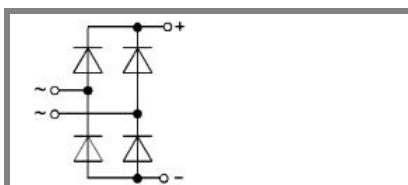

SKB

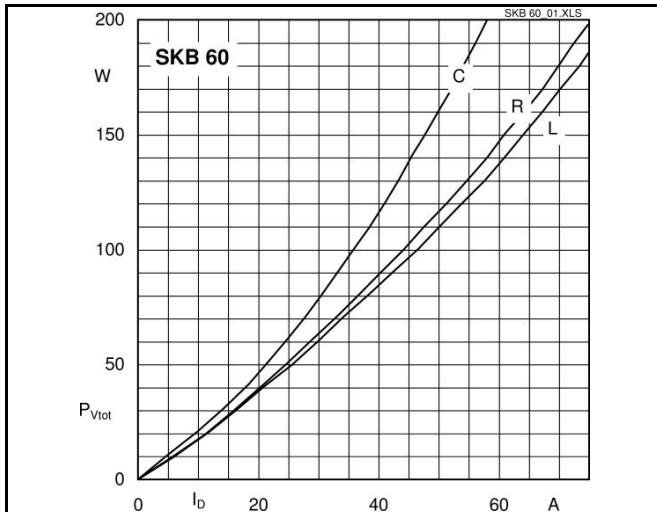

Fig. 3L Power dissipation vs. output current

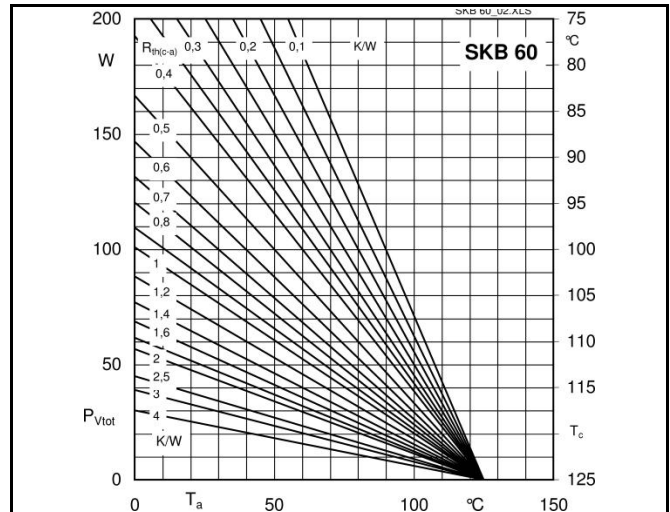

Fig. 3R Power dissipation vs. case temperature

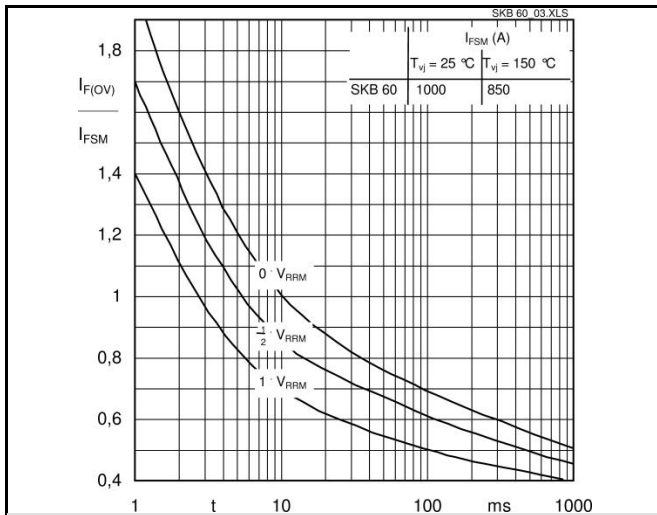

Fig. 6 Surge overload characteristics vs. time

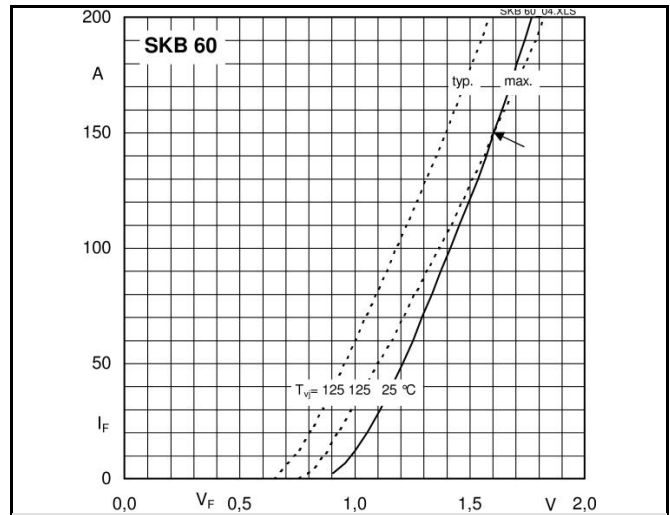

Fig. 9 Forward characteristics of a diode arm

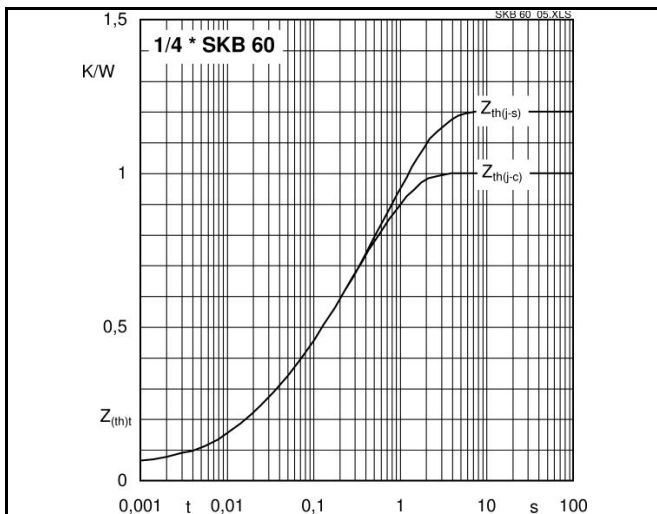
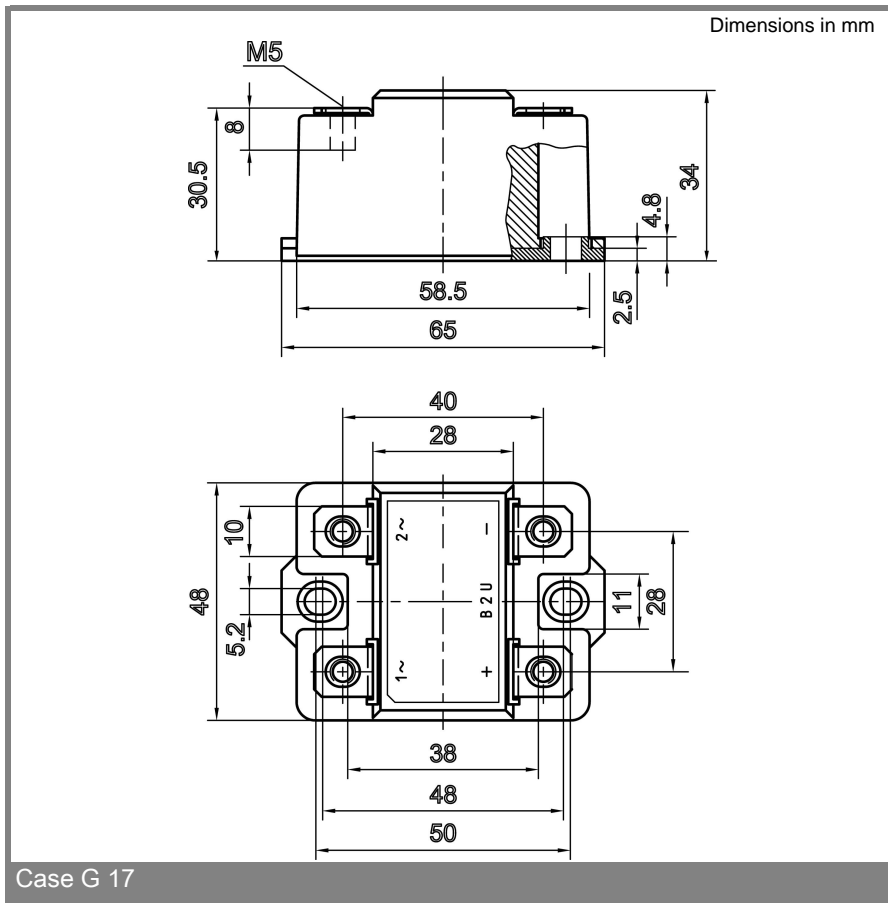

Fig. 12 Transient thermal impedance vs. time



Case G 17

This technical information specifies semiconductor devices but promises no characteristics. No warranty or guarantee expressed or implied is made regarding delivery, performance or suitability.