

PC board type

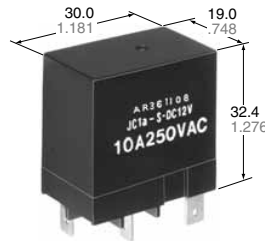

Plug-in type

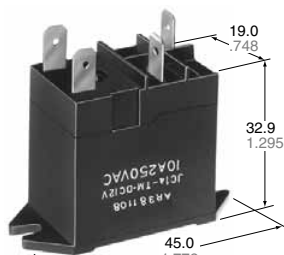

TM type

mm inch

### FEATURES

- **High inrush current capability**
  - 1 Form A: 163 A inrush (TV-8)
  - 2 Form A: 111 A inrush (TV-5)
- **High dielectric withstanding for transient protection:**  
JC can withstand 10,000 V surge in  $\mu$ s between coil and contact.
- **Electrical life:**
  - 1 Form A:  $10^5$  ope. at 15 A 250 V AC resistive load
  - 2 Form A:  $10^5$  ope. at 10 A 250 V AC resistive load
- **UL/CSA, VDE, TÜV, SEMKO also approved.**

### COMMENTS ABOUT Cd FREE

We have introduced Cadmium free type products to reduce the material which is not good for our environment. (The suffix "F" should be added to the part number.) If you are still using Cadmium containing parts, which don't have "F" on the suffix of the part number, please use Cadmium free parts from now on. The life of the Cadmium free parts may be shorter than the Cadmium containing parts based on the load condition, so please evaluate the Cadmium free parts with your actual application before use.

Compliance with RoHS Directive

### SPECIFICATIONS

#### Contact

Arrangement		1 Form A	2 Form A
Initial contact resistance, max. (By voltage drop 6 V DC 1 A)		30 m $\Omega$	
Contact material		AgSnO <sub>2</sub> type	
Contact force, min.		30 g	
Rating (resistive load)	Maximum switching power	3,750 VA	2,500 VA
	Maximum switching voltage	250 V AC	250 V AC
	Max. switching current	15 A	10 A
	Min. switching capacity*1	100 mA, 5 V DC	
Expected life (min. operation)	Mechanical	5 $\times$ 10 <sup>6</sup>	
	Electrical (resistive)	10 A 250 V AC	10 <sup>5</sup>
		5A 250 V AC	10 <sup>5</sup>

#### Coil

Nominal operating power	900 mW	1,000 mW
-------------------------	--------	----------

#1 This value can change due to the switching frequency, environmental conditions, and desired reliability level, therefore it is recommended to check this with the actual load.

#### Remarks

- \* Specifications will vary with foreign standards certification ratings.
- \*1 Measurement of same location as "Initial breakdown voltage" section
- \*2 Detection current: 10mA
- \*3 Excluding contact bounce time
- \*4 Half-wave pulse of sine wave: 11ms; detection time: 10 $\mu$ s
- \*5 Half-wave pulse of sine wave: 6ms
- \*6 Detection time: 10 $\mu$ s
- \*7 Refer to 6. Conditions for operation, transport and storage mentioned in AMBIENT ENVIRONMENT

#### Characteristics

Maximum operating speed	20 cpm.	
Initial insulation resistance*1	Min. 100 M $\Omega$ at 500 V DC	
Initial breakdown voltage*2	Between open contacts	2,000 V rms for 1 min.
	Between contacts sets	2,000 Vrms for 1 min.
	Between contacts and coil	4,000 Vrms for 1 min.
Operate time*3 (at nominal voltage)	Max. 30 ms	
Release time(without diode)*3 (at nominal voltage)	Max. 10 ms	
Temperature rise (at nominal voltage)	Max. 55°C	
Shock resistance	Functional*4	196 m/s <sup>2</sup> {20 G}
	Destructive*5	980 m/s <sup>2</sup> {100 G}
Vibration resistance	Functional*6	98 m/s <sup>2</sup> {10 G}, 10 to 55 Hz at double amplitude of 1.6 mm
	Destructive	117.6 m/s <sup>2</sup> {12 G}, 10 to 55 Hz at double amplitude of 2 mm
Conditions for operation, transport and storage*7 (Not freezing and condensing at low temperature)	Ambient temp.	-50°C to +60°C -58°F to +140°F
	Humidity	5 to 85%R.H.
Unit weight	Approx. 31 g 1.09 oz	

# TYPICAL APPLICATIONS

- Automatic garage door openers
- Microwave ovens
- Dryers
- Vending machines
- Copiers
- Air conditioners
- Stereo equipment
- TV sets

# ORDERING INFORMATION

Ex. JC 1a F — TM — DC12V — F

Contact arrangement	Mounting classification	Coil voltage	Contact material
1a: 1 Form A 2a: 2 Form A	Nil: PC board terminal S: Plug-in terminal TM: Top mounting	DC 5, 6, 12, 24, 48 V	F: AgSnO <sub>2</sub> type

- (Notes) 1. TV rated types available 1 Form A: TV-8; 2 Form A: TV-5.  
 2. Standard packing Carton: 50 pcs.; Case: 200 pcs.  
 3. UL/CSA, VDE, TÜV, and SEMKO certified products can also be supported. Please consult us.  
 4. Please inquire about the previous products (Cadmium containing parts).

# COIL DATA (at 20°C 68°F)

Contact arrangement	Nominal voltage. V DC	Pick-up voltage. V DC (max.)	Drop-out voltage. V DC (min.)	Coil resistance, Ω(±10%)	Nominal operating current, mA	Nominal operating power, W	Maximum allowable voltage, V DC (at 60°C)
1 Form A	6	4.8	0.6	40	150	0.9	6.6
	12	9.6	1.2	160	75	0.9	13.2
	24	19.2	2.4	640	37.5	0.9	26.4
	48	38.4	4.8	2,560	18.8	0.9	52.8
2 Form A	6	4.8	0.6	36	166.6	1.0	6.6
	12	9.6	1.2	144	83.3	1.0	13.2
	24	19.2	2.4	576	41.6	1.0	26.4
	48	38.4	4.8	2,304	20.8	1.0	52.8

# DIMENSIONS

mm inch

## PC board type JC1a

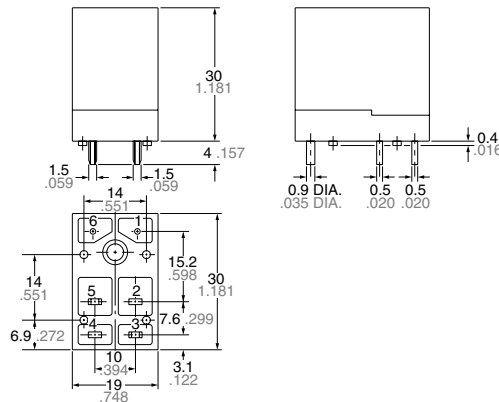

## Schematic

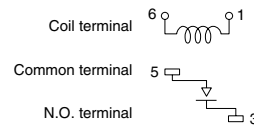

## PC board pattern (Bottom view)

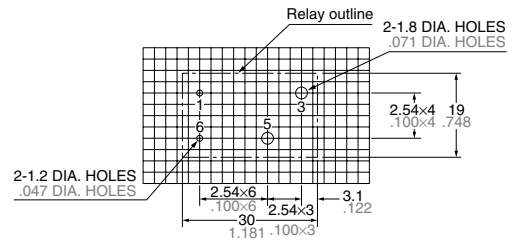

## PC board type JC2a

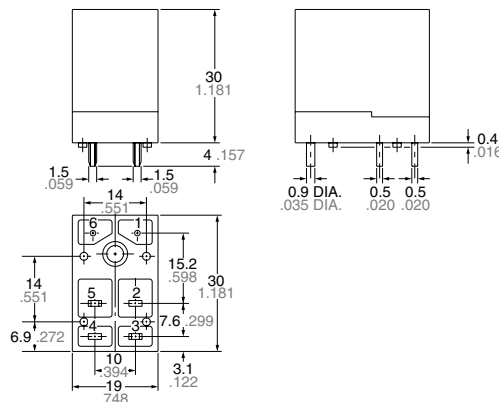

## Schematic

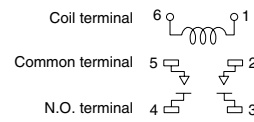

## PC board pattern (Bottom view)

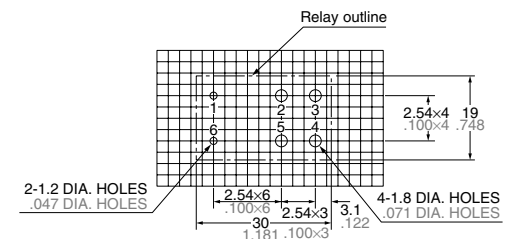

General tolerance: ±0.3 ±0.12

Tolerance: ±0.1 ±0.04

Top mount type

mm inch

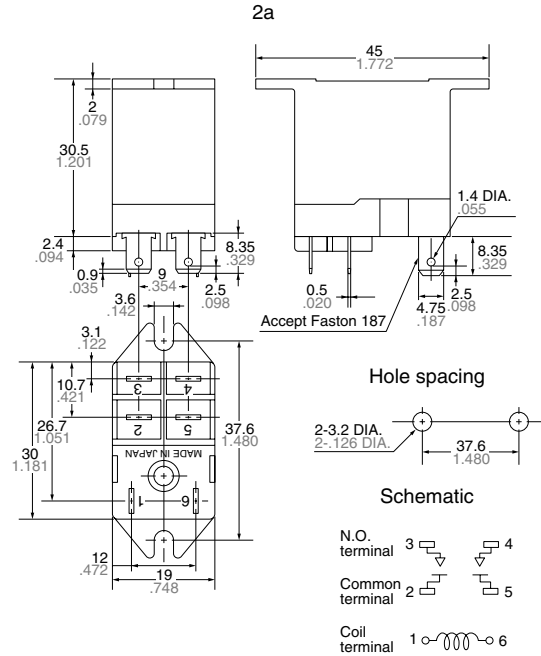
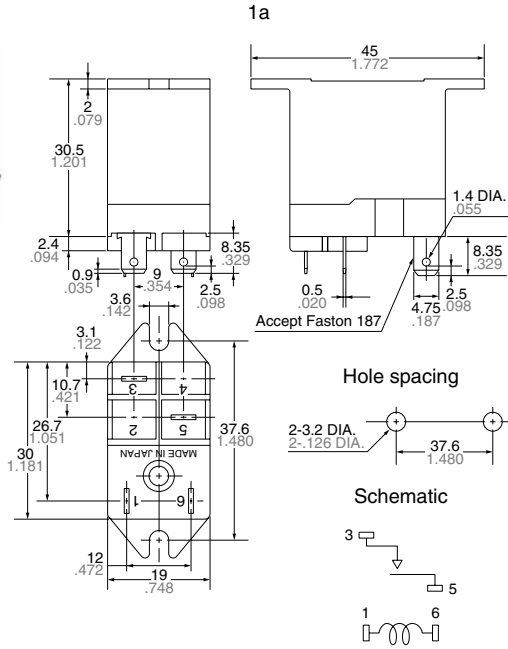

Plug-in type

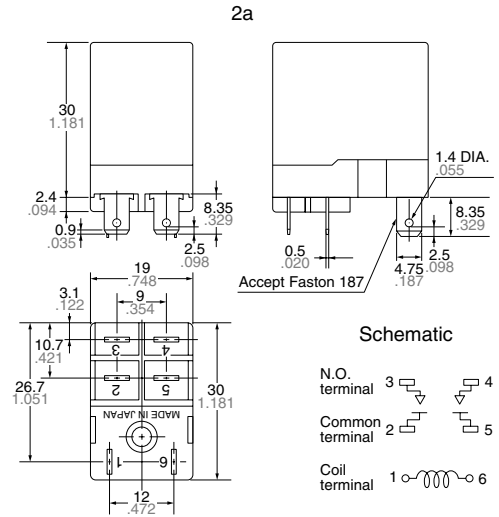
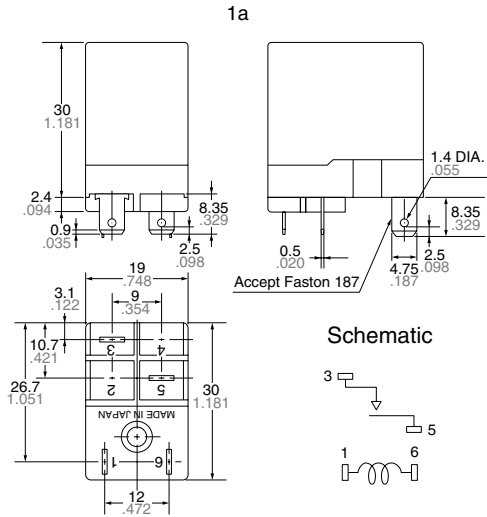

General tolerance:  $\pm 0.3 \pm 0.12$

REFERENCE DATA

JC1a type

1. Maximum value for switching capacity

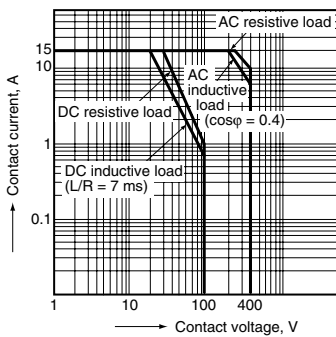

2. Life curve

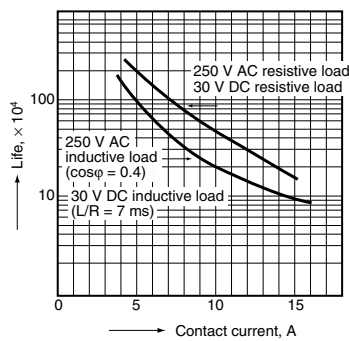

3.-(1) Coil temperature rise

Point measured: Inside the coil  
Ambient temperature: 26°C 79°F

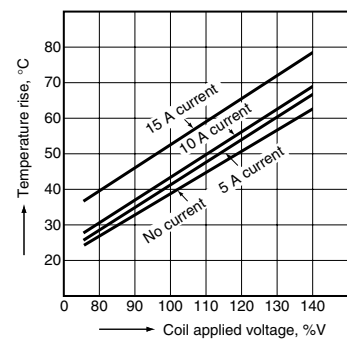

# JC

## 3.-(2) Coil temperature rise

Point measured: Inside the coil  
Ambient temperature: 40°C 104°F

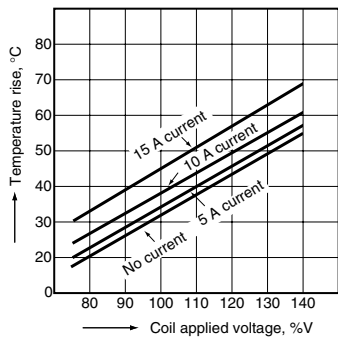

## 3.-(3) Coil temperature rise

Point measured: Inside the coil  
Ambient temperature: 60°C 140°F

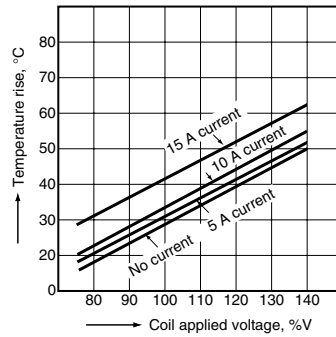

## 4. Operate / release time

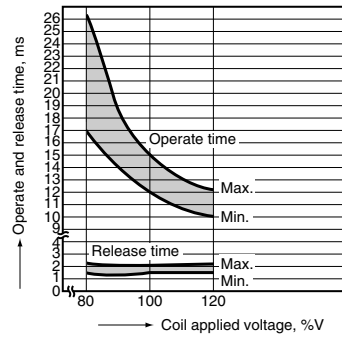

# JC2a type

## 1. Maximum value for switching capacity

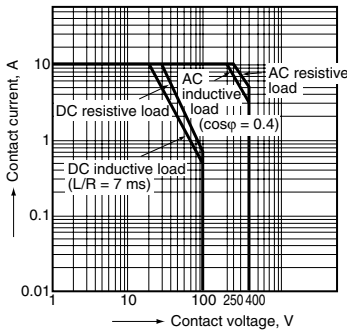

## 2. Life curve

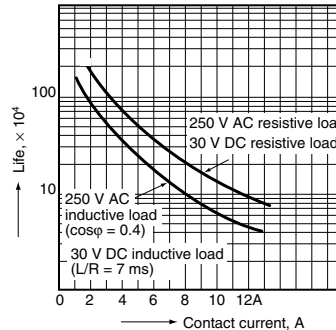

## 3.-(1) Coil temperature rise

Point measured: Inside the coil  
Ambient temperature: 26°C 79°F

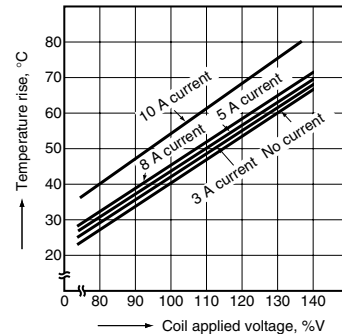

## 3.-(2) Coil temperature rise

Point measured: Inside the coil  
Ambient temperature: 40°C 104°F

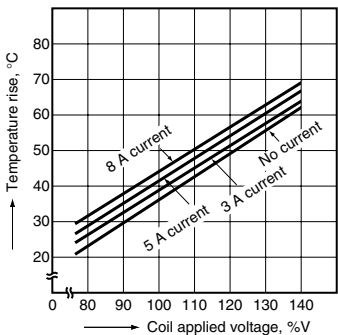

## 3.-(3) Coil temperature rise

Point measured: Inside the coil  
Ambient temperature: 60°C 140°F

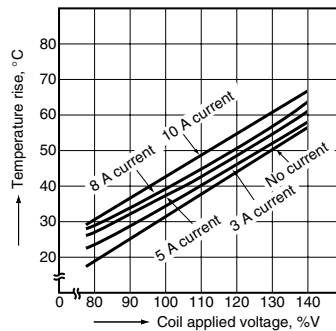

## 4. Operate / release time

