

DATE	REVISIONS	REV
9-27-96	E.C.N. #10241./	A

DRAWING NUMBER	REV
SSB-LXA100SRW	A

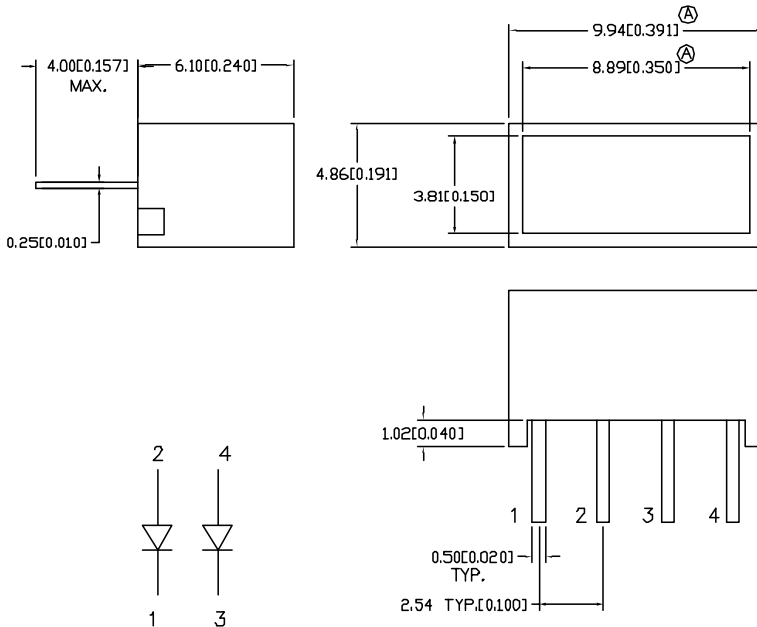

UNIT: mm (INCHES)
TOLERANCE ± 0.25 (± 0.01) UNLESS OTHERWISE SPECIFIED

ELECTRO-OPTICAL CHARACTERISTICS $T_A = 25^\circ\text{C}$ $I_f = 20\text{mA}$

PARAMETER	MIN	TYP	MAX	UNITS	TEST COND
PEAK WAVELENGTH		660 (RED)		nm	
FORWARD VOLTAGE		1.7	2.2	V_f	
REVERSE VOLTAGE	5.0			V_r	$I_r = 100\ \mu\text{A}$
AXIAL INTENSITY		40		mcd	$I_f = 20\text{mA}$
VIEWING ANGLE		160		2x theta	
EMITTED COLOR	RED				
EPOXY LENS FINISH	MILKY WHITE DIFFUSED				

LIMITS OF SAFE OPERATION AT 25°C

PARAMETER	MAX	UNITS
PEAK FORWARD CURRENT*	150	mA
STEADY CURRENT	30	mA
POWER DISSIPATION	100	mW
DERATE FROM 38°C	-0.5	mW/ $^\circ\text{C}$
OPERATING, STORAGE TEMP	-20 TO +85	$^\circ\text{C}$
LEAD SOLDERING TEMP	+230	$^\circ\text{C}$
2.0mm FROM BODY		3 SEC. MAX

* $t < 10\ \mu\text{s}$

RELIABILITY NOTE

OUR MANY YEARS OF EXPERIENCE DATA ACCUMULATION INDICATE THAT SOLDER HEAT IS A MAJOR CAUSE OF EARLY AND FUTURE FAILURE. PLEASE PAY ATTENTION TO YOUR SOLDERING PROCESS.



290 E. HELLEN ROAD
PALATINE, ILLINOIS 60067
(847) 359-2790

CONFIDENTIAL INFORMATION
THE INFORMATION CONTAINED IN THIS DOCUMENT IS THE PROPERTY OF LUMEX OPTO/COMPONENTS, INC. EXCEPT AS SPECIFICALLY AUTHORIZED IN WRITING BY LUMEX OPTO/COMPONENTS, INC., THE HOLDER OF THIS DOCUMENT SHALL KEEP ALL INFORMATION CONTAINED HEREIN CONFIDENTIAL AND SHALL PROTECT SAME IN WHOLE OR IN PART FROM DISCLOSURE AND DISSEMINATION TO ALL THIRD PARTIES.

DATE: 4-8-93	DWN:	CHK'D:	APP'D:
SCALE: N/A			

8.89mm x 3.81mm LIGHT BAR,
MILKY WHITE DIFFUSED

PAGE	DRAWING NUMBER	REV
1 OF 1	SSB-LXA100SRW	A

MS/OK