

**TENMA<sup>®</sup>**

---

**72-6851 & 72-6853**

*PROGRAMMABLE HIGH CURRENT DC POWER SUPPLIES*

---

**INSTRUCTION MANUAL**

# Table of Contents

Specification	2
Safety	4
EMC	5
Installation	6
Connections	6
Manual Operation	7
Maintenance and Repair	10
Remote Operation	11
Remote Commands	20

# Specification

## OUTPUT SPECIFICATIONS

Output Voltage Range:	0V to 35.3V (35V/10A); 0V to 18.15V (18V/20A).
Output Current Range:	0.01A to 10.2A (35V/10A); 0.01A to 20.2A (18V/20A).
Output Voltage Setting:	Direct keyboard entry or quasi-analogue rotary control; setting resolution 10mV.
Output Current Setting:	Direct keyboard entry or quasi-analogue rotary control; setting resolution 10mA.
Output Mode:	Constant voltage or constant current with automatic crossover.
Output Switch:	Electronic. Preset voltage and current displayed when off.
Output Terminals:	4mm terminals on front panel, screw terminals at rear.
Sensing:	Remote via rear panel screw terminals or direct via shorting strip (supplied).
Output Impedance:	<1m $\Omega$ in constant voltage mode. >5k $\Omega$ in constant current mode (voltage limit at max.).
Output Protection:	Forward protection by Over-Voltage-Protection (OVP) trip; maximum voltage that should be applied to the terminals is 50V. Reverse protection by diode clamp for reverse currents up to 3A.
OVP Setting:	Direct keyboard entry.
OVP Range:	1V to 40V (35V/10A); 1V to 25V (18V/20A).
OVP Delay:	<200 $\mu$ s
Load & Line Regulation:	<0.01% of maximum output for 90% load change or 10% line change.
Ripple & Noise:	<1mV rms typical in constant voltage. <3mA rms typical in constant current.
HF Common Mode Noise:	Typically <3mV rms, <10mV peak.
Transient Response:	20 $\mu$ s to within 50mV of setting for 90% load change.
Temperature Coefficient:	typically <100 ppm/ $^{\circ}$ C.
Protection Functions:	Overvoltage trip; regulator overtemperature; sense miswiring.
Status Indication:	Output off lamp; constant voltage mode lamp; constant current mode lamp; trip message on display.

## METER SPECIFICATIONS

Meter Types:	Dual 4 digit meters with 12.5mm (0.5") LEDs. Reading rate 4Hz.
Meter Resolution:	10mV, 10mA
Meter Accuracy:	Voltage 0.2% of reading $\pm$ 1 digit, current 0.5% of reading $\pm$ 1 digit.

## KEYBOARD FUNCTIONS

Delta Mode:	Increase or decrease voltage or current in user-selectable steps.
Store/Recall:	Store and recall voltage, current and OVP levels from non-volatile memory (25 memories).
Interface Selection:	Set digital interface type (RS232 or GPIB), baud rate and address.

Note: All voltage and current levels set via the keyboard are displayed on a separate 0.3" 4-digit display. This entry preview system ensures that the user can observe the value entered before it is effected thus avoiding possible error. The display is also used for setting additional functions. When the output switch is on and no other function is selected, the display shows output power in Watts.

## DIGITAL INTERFACES

Operational Functions:	Set voltage, set current, set OVP; set output on/off; read output voltage; read output current; read output power.
RS232:	Variable baud rate, 9600 baud maximum, 9 pin D-connector (female). Can be controlled as a single instrument or as part of an Addressable RS232 Chain (ARC).
GPIB:	Conforming with IEEE488.1 and IEEE488.2.

## OUTPUT SPECIFICATIONS - REMOTE OPERATION

Output Voltage Setting:	12 bit resolution (10mV steps)
Output Current Setting:	12 bit resolution (10mA steps)
Setting Accuracy:	Voltage: $\pm (0.1\% + 10\text{mV})$ ; Current: $\pm (0.2\% + 20\text{mA})$
Output Switch:	Electronic by interface command.
Readback Resolution:	Voltage: 10mV over the entire range. Current: 10mA over the entire range.
Readback Accuracy:	Voltage: $\pm (0.2\% \text{ of reading} + 1 \text{ digit})$ Current: $\pm (0.5\% \text{ of reading} + 1 \text{ digit})$

## RESPONSE TIME OVER RS232/GPIB:

Interface:	<15ms (single command, buffer empty).
Power Supply:	An internal time constant, T, (typically 22ms) governs the settling time of a step voltage increase. Settling time to within 1% of the step change = 4.6T, to 0.1% = 6.9T, to 0.01% = 9.2T; for example, after a 10V step the output will be within 1 digit (10mV = 0.1%) of its new value in typically 150ms. For load current of 1 Amp or more, settling times for downward steps will be very similar; however, response times will be longer at low loads.

## GENERAL

AC Input Voltage:	115V AC $\pm 14\%$ , 50/60Hz. Installation Category II.
Power Consumption:	700VA max.
Operating Range:	5°C to +40°C, 20% to 80% RH.
Storage Range:	-40°C to +70°C.
Environmental:	Indoor use at altitudes up to 2000m, Pollution Degree 2.
Size:	200 x 140 x 350mm (W x H x D); half rack width x 3U height; (optional rack mounting kit available).
Weight:	5.5kg.
Safety:	Complies with IEC 1010-1
EMC:	Complies with EN50081-1 and EN50082-1

# Safety

This power supply is a Safety Class I instrument according to IEC classification and has been designed to meet the requirements of IEC 1010-1 (Safety Requirements for Electrical Equipment for Measurement, Control and Laboratory Use). It is an Installation Category II instrument intended for operation from a normal single phase supply.

This instrument has been tested in accordance with IEC 1010-1 and has been supplied in a safe condition. This instruction manual contains some information and warnings which have to be followed by the user to ensure safe operation and to retain the instrument in a safe condition.

This instrument has been designed for indoor use in a Pollution Degree 2 environment in the temperature range 5°C to 40°C, 20% - 80% RH (non-condensing). It may occasionally be subjected to temperatures between +5°C and -10°C without degradation of its safety. Do not operate while condensation is present.

Use of this instrument in a manner not specified by these instructions may impair the safety protection provided. Do not operate the instrument outside its rated supply voltages or environmental range.

## WARNING! THIS INSTRUMENT MUST BE EARTHED

Any interruption of the mains earth conductor inside or outside the instrument will make the instrument dangerous. Intentional interruption is prohibited. The protective action must not be negated by the use of an extension cord without a protective conductor.

When the instrument is connected to its supply, terminals may be live and opening the covers or removal of parts (except those to which access can be gained by hand) is likely to expose live parts. The apparatus shall be disconnected from all voltage sources before it is opened for any adjustment, replacement, maintenance or repair. Capacitors inside the power supply may still be charged even if the power supply has been disconnected from all voltage sources but will be safely discharged about 10 minutes after switching off power.





Any adjustment, maintenance and repair of the opened instrument under voltage shall be avoided as far as possible and, if inevitable, shall be carried out only by a skilled person who is aware of the hazard involved.

This instrument uses a Lithium button cell for non-volatile memory battery back-up; typical life is 5 years. In the event of replacement becoming necessary, replace only with a cell of the correct type, i.e. 3V Li/MnO<sub>2</sub> 20mm button cell type 2032. Exhausted cells must be disposed of carefully in accordance with local regulations; do not cut open, incinerate, expose to temperatures above 60°C or attempt to recharge.

If the instrument is clearly defective, has been subject to mechanical damage, excessive moisture or chemical corrosion the safety protection may be impaired and the apparatus should be withdrawn from use and returned for checking and repair.

Make sure that only fuses with the required rated current and of the specified type are used for replacement. The use of makeshift fuses and the short-circuiting of fuse holders is prohibited. Do not wet the instrument when cleaning it.

The following symbols are used on the instrument and in this manual:-

	Earth (ground) terminal.
	mains supply OFF.
	mains supply ON.
	alternating current (ac)
	direct current (dc)

This power supply has been designed to meet the requirements of the European EMC Directive 89/336/EEC.

Compliance was demonstrated by meeting the test limits of the following standards:

### **Emissions**

EN50081-1 (1992) Generic emission standard for residential commercial and light industry. Test methods and limits used were:

- a) EN55022 Conducted, Class B
- b) EN55022 Radiated, Class B

### **Immunity**

EN50082-1 (1992) Generic immunity standard for residential, commercial and light industry. Test methods and limits used were:

- a) EN60801-2 (1993) Electrostatic Discharge, 8kV air discharge.
- b) IEC801-3 (1984) RF Field, 3V/m.
- c) IEC801-4 (1988) Fast Transient, 1kV peak (AC line) and 0.5kV peak (DC output, GPIB and RS232 interfaces) .

### **Cautions**

To ensure continued compliance with the EMC directive the following precautions should be observed:

- a) after opening the case for any reason ensure that all signal and ground connections are remade correctly before replacing the cover. Always ensure all case screws are correctly refitted and tightened.
- b) In the event of part replacement becoming necessary, only use components of an identical type, see the Service Manual.

# Installation

## Mains Operating Voltage

This instrument operates from a nominal 115V mains supply. Check that the local supply meets the AC Input requirement given in the Specification.

## Mains Lead

### **WARNING! THIS APPARATUS MUST BE EARTHED.**

Any interruption of the mains earth conductor inside or outside the instrument will make the instrument dangerous. Intentional interruption is prohibited.

## Mounting

This instrument is suitable both for bench use and rack mounting. It is delivered with feet for bench mounting. The front feet include a tilt mechanism for optimal panel angle.

A rack kit for mounting one or two of these Half-width 3U high units in a 19" rack is available from the Manufacturers.

## Ventilation

These instruments are very efficient but nevertheless can generate significant heat at full power. The supplies rely on convection cooling only and it is therefore important that ventilation is never restricted if performance and safety are to be maintained. If the supplies are mounted in a restricted space, e.g. a 19 inch rack, then adequate ventilation must be ensured by using, for example, a fan tray.

---

# Connections

The load should be connected to the positive (red) and negative (black) front panel OUTPUT terminals. These safety terminals will accept 4mm plugs, bare-ended wires or spade terminals without exposing any metal parts and are rated to 30A.

The load can alternatively be connected to the rear panel OUTPUT screw terminals where the SENSE connections are also located. Refer to the Connection to the Load section in the Manual Operation chapter for full details.

The terminal marked  is connected to the chassis and safety earth ground.

# Manual Operation

## Front Panel

The POWER switch is used to apply line voltage to the instrument. When switched to on (I) the instrument will be powered and the start-up procedure will be executed; this will take approximately 5 second to complete. If all is well the settings from the last power-down will be installed and the instrument will be ready for use.

The output terminals are located on the right of the front panel. The red terminal is positive and the black terminal is negative. Connection to the output terminals can be made with any of the following: 4mm plugs, spade terminals or wire ends. To minimise voltage drop, the connecting leads to the load should be of an adequate wire gauge and be kept short. The output terminals are duplicated on the rear panel, together with the sense terminals.

The keyboard is located to the left of the output terminals. This consists of 27 keys and a LED indicating the instrument output status. The use of the keyboard to control all instrument functions is discussed in the following sections.

To the left of the keyboard is the status display which consists of a 4-digit, 7-segment display and 10 LEDs. Normally the status display will show the output power (in Watts) when the output is on or will be blank when the output is off; however, other information will appear when selections are made from the keyboard. The relevant annunciator LED will indicate what the contents of the display represent at any time.

Above the keyboard are the main displays and LED indicators which show the conditions of the output. The displays show the set voltage and set current when the output is off and the voltage at the output terminals and output current when the output is on.

To the right of the LED indicators is a continuously rotating control which may be used to make fine adjustments to voltage or current as described later.

## General Principles of Manual Operation

The following sections explain in detail the use of the keyboard to control all instrument functions. If an error is encountered during keyboard operation the status display will show E<sub>nnnn</sub> where nnn is a decimal number. A full list of possible errors is given in the STATUS REPORTING section.

### Set Voltage

The set voltage is normally shown in the top left hand display marked V. The exception to this is when the output is on and in constant current (CI) mode. In this case the actual output voltage will be less than the set value and will be shown instead.

To set the voltage press the VOLTS key. The status display will show the set voltage value and the VOLTS LED will light. A new value may now be entered from the numeric keypad. The value will be in Volts and the POINT key may be used to enter decimal digits. Once the required value is entered press the CONFIRM key and the set voltage will be updated immediately. To exit without making any changes press the ESCAPE key. If a mistake is made during entry press the VOLTS key and start again. The maximum and minimum values accepted will depend on the particular model, see the specification section for details.

### Set Current

When the output is off the set current is shown in the top right hand display marked A. When the output is on and in constant voltage (CV) mode the output current is shown. When in constant current (CI) mode the output current is equal to the set current and this is shown.

To set the current press the AMPS key. The status display will show the set current value and the AMPS LED will light. A new value may now be entered from the numeric keypad. The value will be in Amps and the POINT key may be used to enter decimal digits. Once the required value is



entered press the CONFIRM key and the set current will be updated immediately. To exit without making any changes press the ESCAPE key. If a mistake is made during entry press the AMPS key and start again.

The maximum and minimum values accepted will depend on the particular model, see the specification section for details.

## Set OVP

The Over-Voltage Protection (OVP) value is not shown in the main display; however, it is active and if at any time the actual value of the output voltage exceeds the set value the OVP circuit will immediately shut down the output, thus avoiding any damage to the circuit under test. The OVP circuit will protect against adjustments by the user or the GPIB or RS232, external voltages impressed across the output terminals, or a failure in the circuitry of the instrument itself. If the OVP circuit trips for any reason the main displays will both show `trip` and the output will be shut down, i.e. switched off. The system will then attempt to recover from the trip and if successful the `trip` message will be removed and normal operation will resume.

To set the OVP press the OVP key. The status display will show the set OVP value and the OVP LED will light. A new value may now be entered from the numeric keypad. The value will be in VOLTS and the POINT key may be used to enter decimal digits. Once the required value is entered press the CONFIRM key and the set OVP will be updated immediately. To exit without making any changes press the ESCAPE key. If a mistake is made during entry press the OVP key and start again.

The maximum and minimum values accepted will depend on the particular model, see the specification section for details.

## Delta Volts

Delta Volts mode is entered by pressing the  $\Delta V$  key. The status display will show the set Delta Volts value and the  $\Delta V$  LED will light. A new value may now be entered from the numeric keypad. The value will be in Volts and the POINT key may be used to enter decimal digits. Once the required value is entered press the CONFIRM key and the set Delta Volts value will be updated immediately. To exit without making any changes press the ESCAPE key. If a mistake is made during entry press the  $\Delta V$  key and start again.

Whilst in Delta Volts mode, i.e. while the  $\Delta V$  LED is on, the  $\Delta$  and  $\nabla$  keys are active and will increment or decrement the set volts value by the set  $\Delta V$  value shown in the status display. The V LED next to the knob will also be on indicating that the knob is active for adjusting volts. Turning the knob will increment or decrement the set volts value in 10mV steps irrespective of the set  $\Delta V$  value.

The maximum value for  $\Delta V$  is 1.00V. The minimum value is 0.00V.

## Delta Amps

Delta Amps mode is entered by pressing the  $\Delta I$  key. The status display will show the set Delta Amps value and the  $\Delta I$  LED will light. A new value may now be entered from the numeric keypad. The value will be in Amps and the POINT key may be used to enter decimal digits. Once the required value is entered press the CONFIRM key and the set Delta Amps value will be updated immediately. To exit without making any changes press the ESCAPE key. If a mistake is made during entry press the  $\Delta I$  key and start again.

Whilst in Delta Amps mode, i.e. while the  $\Delta I$  LED is on, the  $\Delta$  and  $\nabla$  keys are active and will increment or decrement the set current value by the set  $\Delta I$  value shown in the status display. The A LED next to the knob will also be on indicating that the knob is active for adjusting current. Turning the knob will increment or decrement the set current value in 10mA steps irrespective of the set  $\Delta I$  Amps value.

The maximum value for  $\Delta I$  is 1.00A. The minimum value is 0.00A.

## Current Meter Damping

The output current meter damping is toggled on and off by pressing the DAMPING key. When damping is on the DAMP LED will also be on.

## Output On/Off

The output is alternately turned on and off by pressing the OUTPUT key. The status is shown by the ON LED next to the key.

## Store Settings

The instrument contains 25 stores each capable of holding the entire set-up. The stored data is non-volatile and is retained while power is off.

To save the instrument set-up to a store press the STORE key. The status display will show the number of the last store which was accessed. This store may be used or a new store number may be entered from the numeric key pad. When the required value is displayed press the CONFIRM key to store the data in that store. Pressing the ESCAPE key will exit without making any changes.

## Recall Settings

The instrument contains 25 stores each capable of holding the entire set-up. The stored data is non-volatile and is retained while power is off.

To recall the instrument set up from a store press the RECALL key. The status display will show the number of the last store which was accessed. This store may be used or a new store number may be entered from the numeric key pad. When the required value is displayed press the CONFIRM key to recall the data from that store. Pressing the ESCAPE key will exit without making any changes.

## Thermal Trip

If the instrument overheats a thermal trip will occur and the main displays will show the `trip` message. The output will then be shut down, i.e. the output will be switched off. This condition will persist until the instrument cools to below the trip temperature value, when the output will be usable again.

## Connection to the Load

### Output Terminals

Connection to the front panel output terminals can be made with 4mm plugs, spade terminals or wire ends. To minimise voltage drop, the connecting leads to the load should be of an adequate wire gauge and be kept short. Load wires should also be twisted together to reduce inductance.

The output is fully floating and either terminal can be connected to ground or raised by up to 300V peak above true ground; however, such voltages are hazardous and great care should be taken.

The current limit can be set to limit the continuous output current to levels down to 10mA. However, in common with all precision bench power supplies, a capacitor is connected across the output to maintain stability and good transient response. This capacitor charges to the output voltage, and short circuiting of the output will produce a short current pulse as the capacitor discharges which is independent of the current limit setting.

### Sense Terminals

To overcome errors introduced by connecting lead resistance at higher currents (10mΩ of lead resistance will drop 0.2V at 20 Amps) the remote sensing facility should be used. Remove the two shorting links made between the rear output and sense terminals and connect the sense terminals directly to the load; the power connections may be made from either the front or rear terminals. To ensure good coupling between the output and sense, the sense wires should be twisted with their corresponding output leads before the output leads are twisted together.

The voltage drop in each output lead must not exceed 1V.

The shorting links should be re-made between the rear sense and output terminals when remote sensing is not being used. However, the sense connection is also made internally through a low value resistor and only a small error between the set and actual voltage will result if the links are left disconnected.

### Sense Miswiring Trip

The output will be tripped off if the sense wires are wired to the wrong output or if an attempt is made to draw power from the sense wires; the `trip` message will be shown in both displays. The system will then attempt to recover from the trip and, if successful (because the wiring has been corrected), the `trip` message will be removed and normal operation will resume.

### Output Protection

In addition to OVP for forward overvoltage protection, the output is protected from reverse voltages by a diode; the continuous reverse current must not exceed 3 Amps, although transients can be much higher.

---

## Maintenance and Repair

For service repair and calibration please contact your local Tenma distributor or go to [www.tenma.com](http://www.tenma.com)

### Fuse

The correct fuse type is:

10 Amp 300V HBC time-lag, 5 x 20mm

Make sure that only fuses with the required rated current and of the specified type are used for replacement. The use of makeshift fuses and the short-circuiting of fuse-holders is prohibited.

To replace the fuse, first disconnect the instrument from the AC supply. Remove the 6 cover securing screws and lift off the cover. Replace the fuse with one of the correct type and refit the cover.

Note that the main function of the fuse is to make the instrument safe and limit damage in the event of failure of one of the switching devices. If a fuse fails it is therefore very likely that the replacement will also blow, because the supply has developed a fault; in such circumstances the instrument will need to be returned to the manufacturer for service.

### Cleaning

If the PSU requires cleaning use a cloth that is only lightly dampened with water or a mild detergent. Polish the display window with a soft dry cloth.

**WARNING! TO AVOID ELECTRIC SHOCK, OR DAMAGE TO THE PSU, NEVER ALLOW WATER TO GET INSIDE THE CASE. TO AVOID DAMAGE TO THE CASE OR DISPLAY WINDOW NEVER CLEAN WITH SOLVENTS.**

## Remote Operation

The instrument can be remotely controlled via its RS232 or GPIB interfaces. When using RS232 it can either be the only instrument connected to the controller or it can be part of an Addressable RS232 Chain (ARC) which permits up to 32 instruments to be addressed from one RS232 port.

Some of the following sections are general and apply to all 3 modes (single instrument RS232, ARC and GPIB); others are clearly only relevant to a particular interface or mode. It is only necessary to read the general sections plus those specific to the intended remote control mode.

Remote command format and the remote commands themselves are detailed in the Remote Commands chapter.

### Interface Selection

All power supplies in the range are fitted with both an ARC (Addressable RS232 Chain) interface and a GPIB interface. Before an interface can be used it must be selected and assigned an address and/or baud rate. To select an interface press the I/F key. The status display will show either "232" if RS232 is currently selected or "488" if GPIB is selected. The selected interface may be changed by pressing the  $\Delta$  or  $\Delta$  keys. Once the required interface is in the display press the CONFIRM key to make it active. Pressing the ESCAPE key will exit without making any changes.

### Address and Baud Rate Selection

For successful operation, each instrument connected to the GPIB or Addressable RS232 Chain (ARC) must be assigned a unique address and, in the case of addressable RS232, all must be set to the same baud rate.

Pressing the BAUD/ADDR key will alternately show baud rate or address if RS232 is selected or address only if GPIB is selected; the BAUD/ADDR LED will also be on.

To select baud rate the  $\Delta$  and  $\Delta$  keys are used to cycle through all available values. When the required value is displayed press the CONFIRM key to make it active. Pressing the ESCAPE key will exit without making any changes. Selectable baud rates are 300, 600, 1200, 2400, 4800 and 9600.

To select address enter the required number from the numeric key pad. When the required value is displayed press the CONFIRM key to make it active. Pressing the ESCAPE key will exit without making any changes. The range of addresses accepted is 0 to 30.

A change of address will become active immediately it is entered from the keyboard and the device will no longer respond to the previous address.

All device operations are performed through a single primary address, no secondary addressing is used; the default address is 11. When the address is changed the new setting is stored in non-volatile ram, and will remain unchanged even while power is off.

The address setting is ignored in single instrument RS232 operation.

### Remote/Local Operation

At power-on the instrument will be in the local state with the REMOTE LED off. In this state all keyboard operations are possible. When the instrument is addressed (to talk or listen) the remote state will be entered and the REMOTE LED will be turned on. In this state the keyboard is locked out and remote commands only will be processed. The instrument may be returned to the local state by pressing the LOCAL key; however, the effect of this action will remain only until the instrument is addressed again or receives another character from the interface, when the remote state will once again be entered. The Controller may disable the LOCAL key under GPIB control by sending a Local Lock Out command; the instrument keyboard will then remain inoperative until the Controller sends a Go To Local command or sets the REN interface line false.

## RS232 Interface

### RS232 Interface Connector

The 9-way D-type serial interface connector is located on the instrument rear panel. The pin connections are as shown below:

Pin	Name	Description
1	-	No internal connection
2	TXD	Transmitted data from instrument
3	RXD	Received data to instrument
4	-	No internal connection
5	GND	Signal ground
6	-	No internal connection
7	RXD2	Secondary received data (addressable RS232 only)
8	TXD2	Secondary transmitted data (addressable RS232 only)
9	GND	Signal ground (addressable RS232 only)

### Single Instrument RS232 Connections

For single instrument remote control only pins 2, 3 and 5 are connected to the PC. However, for correct operation links must be made in the connector at the PC end between pins 1, 4 and 6 and between pins 7 and 8, see diagram. Pins 7 and 8 of the instrument must **not** be connected to the PC, i.e. do not use a fully wired 9-way cable.

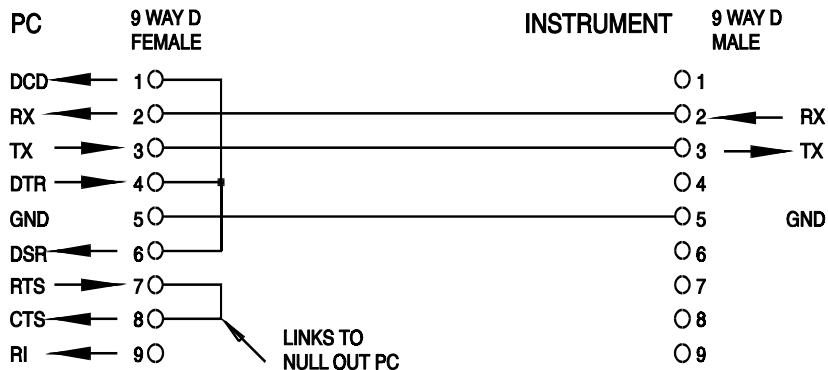

Baud Rate is set as described above in Address and Baud Rate Selection; the other parameters are fixed as follows:

Start Bits: 1                      Parity: None  
 Data Bits: 8                      Stop Bits: 1

### Addressable RS232 Connections

For addressable RS232 operation pins 7, 8 and 9 of the instrument connector are also used. Using a simple cable assembly, a 'daisy chain' connection system between any number of instruments, up to the maximum of 32 can be made, as shown below:

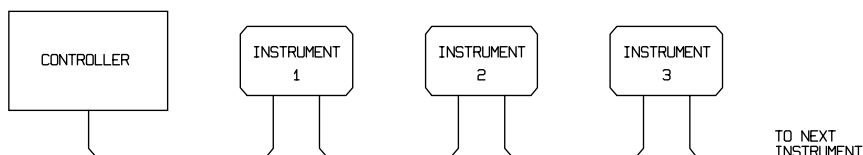

The daisy chain consists of the transmit data (TXD), receive date (RXD) and signal ground lines only. There are no control/handshake lines. This makes XON/XOFF protocol essential and allows

the inter-connection between instruments to contain just 3 wires. The wiring of the adaptor cable is shown below:

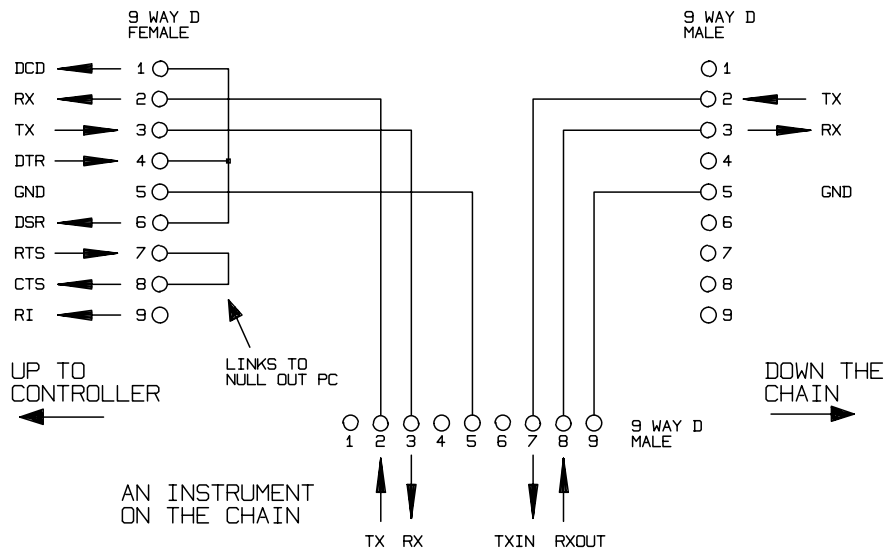

All instruments on the interface must be set to the same baud rate and all must be powered on, otherwise instruments further down the daisy chain will not receive any data or commands.

The other parameters are fixed as follows:

Start Bits: 1

Parity: None

Data Bits: 8

Stop Bits: 1

### RS232 Character Set

Because of the need for XON/XOFF handshake it is possible to send ASCII coded data only; binary blocks are not allowed. Bit 7 of ASCII codes is ignored, i.e. assumed to be low. No distinction is made between upper and lower case characters in command mnemonics and they may be freely mixed. The ASCII codes below 20H (space) are reserved for addressable RS232 interface control. In this manual 20H, etc. means 20 in hexadecimal

### Addressable RS232 (ARC) Interface Control Codes

All instruments intended for use on the ARC bus use the following set of interface control codes. Codes between 00H and 1FH which are not listed here as having a particular meaning are reserved for future use and will be ignored. Mixing interface control codes inside instrument commands is not allowed except as stated below for CR and LF codes and XON and XOFF codes.

When an instrument is first powered on it will automatically enter the Non-Addressable mode. In this mode the instrument is not addressable and will not respond to any address commands. This allows the instrument to function as a normal RS232 controllable device. This mode may be locked by sending the Lock Non-Addressable mode control code, 04H. The controller and instrument can now freely use all 8 bit codes and binary blocks but all interface control codes are ignored. To return to addressable mode the instrument must be powered off.

To enable addressable mode after an instrument has been powered on the Set Addressable Mode control code, 02H, must be sent. This will then enable all instruments connected to the ARC bus to respond to all interface control codes. To return to Non-Addressable mode the Lock Non-Addressable mode control code must be sent which will disable addressable mode until the instruments are powered off.

Before an instrument is sent a command it must be addressed to listen by sending the Listen Address control code, 12H, followed by a single character which has the lower 5 bits corresponding to the unique address of the required instrument, e.g. the codes A-Z or a-z give

the addresses 1-26 inclusive while @ is address 0 and so on. Once addressed to listen the instrument will read and act upon any commands sent until the listen mode is cancelled.

Because of the asynchronous nature of the interface it is necessary for the controller to be informed that an instrument has accepted the listen address sequence and is ready to receive commands. The controller will therefore wait for Acknowledge code, 06H, before sending any commands, The addressed instrument will provide this Acknowledge. The controller should time-out and try again if no Acknowledge is received within 5 seconds.

Listen mode will be cancelled by any of the following interface control codes being received:

- 12H Listen Address followed by an address not belonging to this instrument.
- 14H Talk Address for any instrument.
- 03H Universal Unaddress control code.
- 04H Lock Non-Addressable mode control code.
- 18H Universal Device Clear.

Before a response can be read from an instrument it must be addressed to talk by sending the Talk Address control code, 14H, followed by a single character which has the lower 5 bits corresponding to the unique address of the required instrument, as for the listen address control code above. Once addressed to talk the instrument will send the response message it has available, if any, and then exit the talk addressed state. Only one response message will be sent each time the instrument is addressed to talk.

Talk mode will be cancelled by any of the following interface control codes being received:

- 12H Listen Address for any instrument.
- 14H Talk Address followed by an address not belonging to this instrument.
- 03H Universal Unaddress control code.
- 04H Lock Non-Addressable mode control code.
- 18H Universal Device Clear.

#### *Full List of Addressable RS232 (ARC) Interface Control Codes*

- 02H Set Addressable Mode.
- 03H Universal Unaddress control code.
- 04H Lock Non-Addressable mode control code.
- 06H Acknowledge that listen address received.
- 0AH Line Feed (LF); used as the universal command and response terminator.
- 0DH Carriage Return (CR); formatting code, otherwise ignored.
- 11H Restart transmission (XON).
- 12H Listen Address - must be followed by an address belonging to the required instrument.
- 13H Stop transmission (XOFF).
- 14H Talk Address - must be followed by an address belonging to the required instrument.
- 18H Universal Device Clear.

## **GPIB Interface**

The 24-way GPIB connector is located on the instrument rear panel.

The pin connections are as specified in IEEE Std. 488.1-1987 and the instruments in the range comply with IEEE Std. 488.1-1987 and IEEE Std. 488.2-1987 and contain the following IEEE 488.1 subsets.



## GPIB Subsets

This instrument contains the following IEEE 488.1 subsets:

Source Handshake	SH1
Acceptor Handshake	AH1
Talker	T6
Listener	L4
Service Request	SR1
Remote Local	RL1
Parallel Poll	PP1
Device Clear	DC1
Device Trigger	DT0*
Controller	C0
Electrical Interface	E2

- \* Although no Device Trigger capability is included, the GET message will not cause a command error unless its position in the input stream dictates that it should; e.g. buried inside a <PROGRAM MESSAGE UNIT>.

## GPIB IEEE Std. 488.2 Error Handling

The IEEE 488.2 UNTERMINATED error (addressed to talk with nothing to say) is handled as follows. **If** the instrument is addressed to talk **and** the response formatter is inactive **and** the input queue is empty **then** the UNTERMINATED error is generated. This will cause the Query Error bit to be set in the Standard Event Status Register, a value of 3 to be placed in the Query Error Register and the parser to be reset. See the Status Reporting section for further information.

The IEEE 488.2 INTERRUPTED error is handled as follows. **If** the response formatter is waiting to send a response message **and** a <PROGRAM MESSAGE TERMINATOR> has been read by the parser **or** the input queue contains more than one END message **then** the instrument has been INTERRUPTED and an error is generated. This will cause the Query Error bit to be set in the Standard Event Status Register, a value of 1 to be placed in the Query Error Register and the response formatter to be reset thus clearing the output queue. The parser will then start parsing the next <PROGRAM MESSAGE UNIT> from the input queue. See the Status Reporting section for further information.

The IEEE 488.2 DEADLOCK error is handled as follows. **If** the response formatter is waiting to send a response message **and** the input queue becomes full **then** the instrument enters the DEADLOCK state and an error is generated. This will cause the Query Error bit to be set in the Standard Event Status Register, a value of 2 to be placed in the Query Error Register and the response formatter to be reset thus clearing the output queue. The parser will then start parsing the next <PROGRAM MESSAGE UNIT> from the input queue. See the Status Reporting section for further information.

## GPIB Parallel Poll

The power supplies offer complete parallel poll capabilities. The Parallel Poll Enable Register is set to specify which bits in the Status Byte Register are to be used to form the *ist* local message. The Parallel Poll Enable Register is set by the \*PRE <nrf> command and read by the \*PRE? command. The value in the Parallel Poll Enable Register is ANDed with the Status Byte Register; if the result is zero then the value of *ist* is 0 otherwise the value of *ist* is 1.

The instrument must also be configured so that the value of *ist* can be returned to the controller during a parallel poll operation. The instrument is configured by the controller sending a Parallel Poll Configure command (PPC) followed by a Parallel Poll Enable command (PPE). The bits in the PPE command are shown below:

bit 7 =	X	don't care
---------	---	------------



bit 6 =	1	Parallel poll enable
bit 5 =	1	
bit 4 =	0	
bit 3 =	Sense - sense of the response bit; 0 = low, 1 = high	
bit 2 =	?	bit position of the response
bit 1 =	?	
bit 0 =	?	

*Example.* To return the RQS bit (bit 6 of the Status Byte Register) as a 1 when true and a 0 when false in bit position 1 in response to a parallel poll operation send the following commands

\*PRE 64<pmt>, then PPC followed by 69H (PPE)

The parallel poll response from the generator will then be 00H if RQS is 0 and 01H if RQS is 1.

During parallel poll response the DIO interface lines are resistively terminated (passive termination). This allows multiple devices to share the same response bit position in either wired-AND or wired-OR configuration, see IEEE 488.1 for more information.

## Status Reporting

This section describes the complete status model of the instrument. Note that some registers are specific to the GPIB section of the instrument and are of limited use in an RS232 environment.

### Standard Event Status and Standard Event Status Enable Registers

These two registers are implemented as required by the IEEE std. 488.2.

Any bits set in the Standard Event Status Register which correspond to bits set in the Standard Event Status Enable Register will cause the ESB bit to be set in the Status Byte Register.

The Standard Event Status Register is read and cleared by the \*ESR? command. The Standard Event Status Enable register is set by the \*ESE <nrf> command and read by the \*ESE? command.

- Bit 7 - Power On. Set when power is first applied to the instrument.
- Bit 6 - Not used.
- Bit 5 - Command Error. Set when a syntax type error is detected in a command from the bus. The parser is reset and parsing continues at the next byte in the input stream.
- Bit 4 - Execution Error. Set when an error is encountered while attempting to execute a completely parsed command. The appropriate error number will be reported in the Execution Error Register, as listed below:
  - 001 Checksum error in non-volatile ram at power on.
  - 002 Output stage failed to respond - possibly a system fault.
  - 003 Output stage trip has occurred - attempting to recover.
  - 100 Maximum set voltage value exceeded.
  - 101 Maximum set amps value exceeded.
  - 102 Minimum set voltage exceeded.
  - 103 Minimum set amps value exceeded.
  - 104 Maximum delta voltage value exceeded.
  - 105 Maximum delta amps value exceeded.

- 107 Minimum set OVP value exceeded.
  - 108 Maximum set OVP value exceeded.
  - 109 Minimum delta amps value exceeded.
  - 110 Minimum delta voltage value exceeded.
  - 114 Illegal bus address requested.
  - 115 Illegal store number.
  - 116 Recall empty store requested.
  - 117 Stored data is corrupt.
  - 118 Output stage has tripped (OVP or Temperature).
  - 119 Value out of range.
- Bit 3 - Operation Time-out Error. Set when an attempt is made to set an output to a specific voltage value, with verify specified, and the output Volts do not settle within 5 seconds. this can happen if, for example, a large value of capacitance exists across the output and the current limit is set to a very low value.
- Bit 2 - Query Error. Set when a query error occurs. The appropriate error number will be reported in the Query Error Register as listed below.
- 1 Interrupted error
  - 2 Deadlock error
  - 3 Unterminated error
- Bit 1 - Not used.
- Bit 0 - Operation Complete. Set in response to the \*OPC command.

### Limit Event Status Register and Limit Event Status Enable Register

These two registers are implemented as an addition to the IEEE std.488.2. Their purpose is to allow the controller to be informed of entry to and/or exist from current limit by any output.

Any bits set in the Limit Event Status Register which correspond to bits set in the Limit Event Status Enable Register will cause the LIM bit to be set in the Status Byte Register.

The Limit Event Status Register is read and cleared by the LSR? command. The Limit Event Status Enable register is set by the LSE<nrf> command and read by the LSE? command.

- Bit 7 ... Bit 3 are not used.
- Bit 2 - Set when an output trip has occurred.
- Bit 1 - Set when output enters voltage limit.
- Bit 0 - Set when output enters current limit.

### Status Byte Register and Service Request Enable Register

These two registers are implemented as required by the IEEE std. 488.2.

Any bits set in the Status Byte Register which correspond to bits set in the Service Request Enable Register will cause the RQS/MSS bit to be set in the Status Byte Register, thus generating a Service Request on the bus.

The Status Byte Register is read either by the \*STB? command, which will return MSS in bit 6, or by a Serial Poll which will return RQS in bit 6. The Service Request Enable register is set by the \*SRE <nrf> command and read by the \*SRE? command.

- Bit 7 - FLT. This is the fault bit which will be set when an output fault is detected, i.e. an execution error 002 has occurred.
- Bit 6 - RQS/MSS. This bit, as defined by IEEE Std. 488.2, contains both the Requesting Service message and the Master Status Summary message. RQS is returned in response to a Serial Poll and MSS is returned in response to the \*STB? command.
- Bit 5 - ESB. The Event Status Bit. This bit is set if any bits set in the Standard Event Status Register correspond to bits set in the Standard Event Status Enable Register.
- Bit 4 - MAV. The Message Available Bit. This will be set when the instrument has a response message formatted and ready to send to the controller. The bit will be cleared after the Response Message Terminator has been sent.
- Bit 3 - Not used.
- Bit 2 - Not used.
- Bit 1 - Not used.
- Bit 0 - LIM. The Limit status bit. This bit is set if any bits set in the Limit Event Status Register correspond to bits set in the Limit Event Status Enable Register.

### Status Model

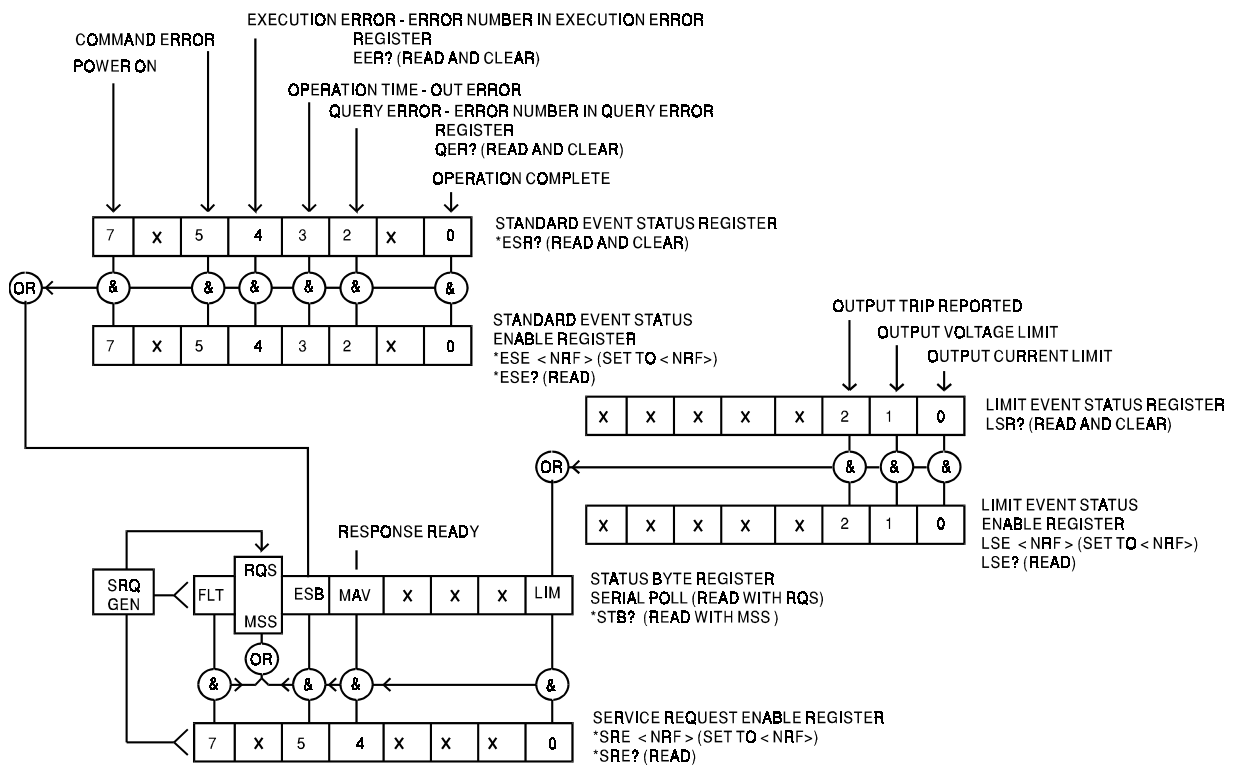

## Power on Settings

Most instrument settings are stored in non-volatile ram and will remain unchanged while power is off. The following instrument status values are set at power on:

	Status Byte Register	= 0
*	Service Request Enable Register	= 0
	Standard Event Status Register	= 128 (pon bit set)
*	Standard Event Status Enable Register	= 0
	Limit Event Status Register	= 0 (Then set to show new limit status)
*	Limit Event Status Enable Register	= 0
	Execution Error Register	= 0
	Query Error Register	= 0
*	Parallel Poll Enable Register	= 0

\* Registers marked thus are specific to the GPIB section of the instrument and are of limited use in an ARC environment.

The standby state will be set and the instrument will be in local with the keyboard active. A complete self-test will be performed just after power up and this will determine the values in the Failed Output Register and the state of the FLT bit in the Status Byte Register.

Due to the non-volatile storage the power on settings are essentially modified by any command, local or remote, which changes any value not listed above. If a defined state is require at start up by the controller the \*RST command should be issued which will load the settings as listed in the description of that command.

If for any reason an error is detected at power up in the non-volatile ram a warning will be issued and all settings will be returned to their default states as for a \*RST command.

# Remote Commands

## RS232 Remote Command Formats

Serial input to the instrument is buffered in a 256 byte input queue which is filled, under interrupt, in a manner transparent to all other instrument operations. The instrument will send XOFF when approximately 200 characters are in the queue. XON will be sent when approximately 100 free spaces become available in the queue after XOFF was sent. This queue contains raw (un-parsed) data which is taken, by the parser, as required. Commands (and queries) are executed in order and the parser will not start a new command until any previous command or query is complete. In non-addressable RS232 mode responses to commands or queries are sent immediately; there is no output queue. In addressable mode the response formatter will wait indefinitely if necessary, until the instrument is addressed to talk and the complete response message has been sent, before the parser is allowed to start the next command in the input queue.

Commands must be sent as specified in the commands list and must be terminated with the command terminator code 0AH (Line Feed, LF). Commands may be sent in groups with individual commands separated from each other by the code 3BH (;). The group must be terminated with command terminator 0AH (Line Feed, LF).

Responses from the instrument to the controller are sent as specified in the commands list. Each response is terminated by 0DH (Carriage Return, CR) followed by 0AH (Line Feed, LF).

<WHITE SPACE> is defined as character codes 00H to 20H inclusive with the exception of those which are specified as Addressable RS232 (ARC) control codes.

<WHITE SPACE> is ignored except in command identifiers. e.g. '\*C LS' is not equivalent to '\*CLS'.

The high bit of all characters is ignored.

The commands are case insensitive.

## GPIB Remote Command Formats

GPIB input to the instrument is buffered in a 256 byte input queue which is filled, under interrupt, in a manner transparent to all other instrument operations. The queue contains raw (un-parsed) data which is taken, by the parser, as required. Commands (and queries) are executed in order and the parser will not start a new command until any previous command or query is complete. There is no output queue which means that the response formatter will wait, indefinitely if necessary, until the instrument is addressed to talk and the complete response message has been sent, before the parser is allowed to start the next command in the input queue.

Commands are sent as <PROGRAM MESSAGES> by the controller, each message consisting of zero or more <PROGRAM MESSAGE UNIT> elements separated by <PROGRAM MESSAGE UNIT SEPARATOR> elements.

A <PROGRAM MESSAGE UNIT> is any of the commands in the remote commands list.

A <PROGRAM MESSAGE UNIT SEPARATOR> is the semi-colon character ';' (3BH).

<PROGRAM MESSAGES> are separated by <PROGRAM MESSAGE TERMINATOR> elements which may be any of the following:

NL        The new line character (0AH)

NL^END   The new line character with the END message

^END        The END message with the last character of the message

Responses from the instrument to the controller are sent as <RESPONSE MESSAGES>. A <RESPONSE MESSAGE> consists of one <RESPONSE MESSAGE UNIT> followed by a <RESPONSE MESSAGE TERMINATOR>.

A <RESPONSE MESSAGE TERMINATOR> is the new line character with the END message NL^END.

Each query produces a specific <RESPONSE MESSAGE> which is listed along with the command in the remote commands list.

<WHITE SPACE> is ignored except in command identifiers. e.g. '\*C LS' is not equivalent to '\*CLS'. <WHITE SPACE> is defined as character codes 00H to 20H inclusive with the exception of the NL character (0AH).

The high bit of all characters is ignored.

The commands are case insensitive.

## Command List

This section lists all commands and queries implemented in this power supply. Those marked (+) are not available under RS232 control.

Note that there are no dependent parameters, coupled parameters, overlapping commands, expression program data elements or compound command program headers and that each command is completely executed before the next command is started.

The following command sections use the following nomenclature:

<pmt> <PROGRAM MESSAGE TERMINATOR>

<rmt> <RESPONSE MESSAGE TERMINATOR>

<nrf> A number in any format. e.g. 12, 12.00, 1.2 e1 and 120 e-1 are all accepted as the number 12. Any number, when received, is converted to the required precision consistent with the use then rounded up to obtain the value of the command.

<nr1> A number with no fractional part, i.e. an integer.

<nr2> A number in fixed point format, e.g. 11.52, 0.78 etc.

## Common Commands

The commands in this section are those specified by IEEE Std. 488.2 as Common commands. All will function when used on the RS232 interface but some are of little use.

\*CLS Sequential command.

Operation complete message generated immediately after execution.

Clear status. Clears the Standard Event Status Register, Limit Event Status Register, Query Error Register and Execution Error Register. This indirectly clears the Status Byte Register.

\*ESE <nrf> Sequential command.

Operation complete message generated immediately after execution.

Set the Standard Event Status Enable Register to the value of <nrf>. If the value of <nrf>, after rounding, is less than 0 or greater than 255 an execution error is generated and error number 119 (out of range) is placed in the Execution Error Register.

- \*ESE?** Sequential command.  
Operation complete message generated immediately after <rmt> is sent.  
Returns the value in the Standard Event Status Enable Register in <nr1> numeric format.  
The syntax of the response is:
- <nr1><rmt>
- Example.* If the Standard Event Status Enable Register contains 01000001b the response to \*ESE? will be 65<rmt>.
- \*ESR?** Sequential command.  
Operation complete message generated immediately after <rmt> is sent.  
Returns the value in the Standard Event Status Register in <nr1> numeric format. The register is then cleared. The syntax of the response is:
- <nr1><rmt>
- Example.* If the Standard Event Status Register contains 01000001b the response to \*ESR? will be 65<rmt>.
- \*IDN?** Sequential command.  
Operation complete message generated immediately after <rmt> is sent.  
Returns the instrument identification. The exact response is determined by the instrument configuration and is of the form
- <NAME>,<model>P,0,<version><rmt>
- where <NAME> is the manufacturer's name, <MODEL> defines the type of instrument and <VERSION> is the revision level of the software installed.
- \*IST?** Sequential command.  
Operation complete message generated immediately after <rmt> is sent.  
Returns **ist** local message as defined by IEEE Std. 488.2. The syntax of the response is
- 0<rmt>
- if the local **ist** message is false or
- 1<rmt>
- if the local **ist** message is true.
- \*LRN?** Sequential command.  
Operation complete message generated immediately after <rmt> is sent.  
Returns the complete set up of the instrument as a character data block. The block contains a series of commands, separated by semi-colons, which specify the complete instrument set up and may thus be returned to the instrument to re-install the set up.  
The syntax of the response is
- LRN #0<Indefinite Length Binary Block data><rmt>
- The size of the character data block is instrument type dependent.  
The settings in the instrument are not affected by execution of the \*LRN? command.

- \*OPC** Sequential command.  
Operation complete message generated immediately after execution.  
Sets the Operation Complete bit (bit 0) in the Standard Event Status Register. This will happen immediately the command is executed because of the sequential nature of all operations.
- \*OPC?** Sequential command.  
Operation complete message generated immediately after <rmt> is sent.  
Query operation complete status. The syntax of the response is  
$$1<rmt>$$
  
The response will be available immediately the command is executed because of the sequential nature of all operations.
- \*PRE <nrf>** Sequential command.  
Operation complete message generated immediately after execution.  
Set the Parallel Poll Enable Register to the value <nrf>. If the value of <nrf>, after rounding, is less than 0 or greater than 255 an execution error is generated and error number 119 (Value out of range) is placed in the Execution Error Register.
- \*PRE?** Sequential command.  
Operation complete message generated immediately after <rmt> is sent.  
Returns the value in the Parallel Poll Enable Register in <nr1> numeric format. The syntax of the response is  
$$<nr1><rmt>$$
  
*Example.* If the Parallel Poll Enable Register contains 01000001b the response to \*PRE? will be 65<rmt>.
- \*RST** Sequential command.  
Operation complete message generated immediately after execution.  
Resets the instrument as follows. The output is set to minimum voltage, minimum current, maximum OVP, meter damping off and output OFF. No other action taken.
- \*RCL <nrf>** Sequential command.  
Operation complete message generated immediately after execution.  
Recall settings from store number <nrf>. The settings in the store pointed to by <nrf> are recalled and installed as the instrument settings. If the value of <nrf> are recalled and installed as the instrument settings. If the value of <nrf>, after rounding, is less than 1 or greater than 25 an execution error is generated and error number 115 (illegal store number) is placed in the Execution Error Register. If the requested store is empty execution error 116 (Recall empty store requested) is generated. If the contents of the selected store are corrupt execution error 117 (Stored data is corrupt) is generated. Any of the above error conditions will result in no change of the instrument settings.  
The scope of the \*RCL command is as follows:  
The output is set to stored values of Volts, current, OVP, delta V and delta A.  
The output status is set to the stored value.



- \*SRE <nrf>** Sequential command.  
Operation complete message generated immediately after execution.  
Set the Service Request Enable Register to <nrf>. If the value of <nrf>, after rounding, is less than 0 or greater than 255 an execution error is generated and error number 119 (Value out of range) is placed in the Execution Error Register.
- \*SRE?** Sequential command.  
Operation complete message generated immediately after <rmt> is sent.  
Returns the value of the Service Request Enable Register in <nr1> numeric format. The syntax of the response is  
$$\text{<nr1><rmt>}$$
*Example.* If the Service Request Enable Register contains 01000001b the response to \*SRE? will be 65<rmt>.
- \*STB?** Sequential command.  
Operation complete message generated immediately after <rmt> is sent.  
Returns the value of the Status Byte Register in <nr1> numeric format. The syntax of the response is  
$$\text{<nr1><rmt>}$$
*Example.* If the Status Byte Register contains 01000001b the response to \*STB? will be 65<rmt>.
- \*SAV <nrf>** Sequential command.  
Operation complete message generated immediately after execution.  
Save settings to store number <nrf>. The instrument settings are saved in the store pointed to by <nrf>. If the value of <nrf>, after rounding, is less than 1 or greater than 25 an execution error is generated and error number 115 (illegal store number) is placed in the Execution Error Register.  
The scope of the \*SAV command is as follows:  
The output is set to stored values of Volts, current, OVP, delta V and delta A.  
The output status is set to the stored value.
- \*TST?** Sequential command.  
Operation complete message generated immediately after <rmt> is sent.  
Examine the state of the FLT bit in the Status byte register and return the result. If the bit is clear the response is  
$$0\text{<rmt>}$$
any failure is indicated by a non-zero FLT bit and the response will be  
$$1\text{<rmt>}$$
  
The value in the FLT bit is 1 if an execution error 002 has been reported since the instrument was powered up.
- \*WAI** Sequential command.  
Operation complete message generated immediately after execution.  
Wait for operation complete true. As all commands are completely executed before the next is started this command takes no additional action.

## Instrument Specific Commands

The commands in this section are additional to those specified by IEEE Std. 488.2 as Common Commands.

- VV <nrf> Sequential command.  
Operation complete message is generated once the new output voltage has settled to within  $\pm 3$  digits or 5% of the required value. If the voltage fails to settle within 5 seconds the Operation Time-out Error (bit 3 in the Standard Event Status Register) will be set and the operation complete message will then be generated.  
Operation complete message is generated once the new output voltage has settled to within  $\pm 3$  digits or 5% of the required value. If the voltage fails to settle within 5 seconds the Operation Time-out Error (bit 3 in the Standard Event Status Register) will be set and the operation complete message will then be generated.  
Set the voltage to <nrf> and verify that the voltage is within  $\pm 3$  counts or 5% of the target value. The value of <nrf> must be in Volts; no multipliers are allowed. If the value of <nrf>, after rounding, is outside the range of the specified output an execution error will be generated and the corresponding error number will be placed in the Execution Error Register, 100 (Maximum set voltage value exceeded) if the value is too large and 102 (Minimum set voltage exceeded) if the value is too small.
- V <nrf> Sequential command.  
Operation complete message generated immediately after execution.  
This command is identical to VV <nrf> above except that no verification of the output voltage is performed, thus saving the possible 500ms required to read back the output voltage. This is useful when it is known that the slew time will be short or during constant current operation.
- I <nrf> Sequential command.  
Operation complete message generated immediately after execution.  
Set current limit to <nrf>. The value of <nrf> must be in Amps; no multipliers are allowed. If the value of <nrf>, after rounding, is outside the range of the specified output an execution error will be generated and the corresponding error number will be placed in the Execution Error Register, 101 (Maximum set Amps value exceeded) if the value is too large or 103 (Minimum set Amps value exceeded) if the value is too small.
- OVP <nrf> Sequential command.  
Operation complete message generated immediately after execution.  
Set OVP to <nrf>. The value of <nrf> must be in Volts; no multipliers are allowed. If the value of <nrf>, after rounding, is outside the range of the specified output an execution error will be generated and the corresponding error number will be placed in the Execution Error Register, 108 (maximum set OVP value exceeded) if the value is too large or 107 (Minimum set OVP value exceeded) if the value is too small.
- V? Sequential command.  
Operation complete message generated immediately after <rmt> is sent.  
Returns the set voltage in Volts in <nr2> numeric format.  
The syntax of the response is  
$$V<nr2><rmt>$$
  
*Example:* If the set voltage is 12.55 Volts the response to the command V? will be  
$$V\ 12.55<rmt>.$$

- I? Sequential command  
Operation complete message generated immediately after <rmt> is sent.  
Returns the current limit in Amps in <nr2> numeric format. The syntax of the response is  
I <nr2><rmt>  
*Example:* If the current limit is 1.000 Amps the response to the command I? will be  
I 1.000<rmt>.
- OVP? Sequential command.  
Operation complete message generated immediately after <rmt> is sent.  
Returns the OVP value in Volts in <nr2> numeric format. The syntax of the response is  
OVP <nr2><rmt>  
*Example:* If the OVP value is 33.00 Volts the response to the command OVP? will be  
OVP 33.00<rmt>.
- VO? Sequential command  
Operation complete message generated immediately after <rmt> is sent.  
Reads and returns the output voltage in Volts in <nr2> numeric format. The syntax of the response is  
<nr2>V<rmt>  
*Example:* If the output voltage is 12.55 Volts the response to the command VO? will be  
12.55V<rmt>.
- IO? Sequential command  
Operation complete message generated immediately after <rmt> is sent.  
Reads and returns the output current in Amps in <nr2> numeric format. The syntax of the response is  
<nr2>A<rmt>  
*Example:* If the output current is 0.934 Amps the response to the command IO? will be  
0.934A<rmt>
- DELTA V <nrf> Sequential command.  
Operation complete message generated immediately after execution.  
Set delta voltage to <nrf>. The value of <nrf> must be in Volts; no multipliers are allowed. If the value of <nrf>, after rounding, is outside the range of the specified output an execution error will be generated and the corresponding error number will be placed in the Execution Error Register, 104 (Maximum delta voltage value exceeded), if the value is too large or 109 (Minimum delta voltage value exceeded) if the value is too small.
- DELTA I <nrf> Sequential command  
Operation complete message generated immediately after execution.  
Set delta Amps to <nrf>. The value of <nrf> must be in Amps; no multipliers are allowed. If the value of <nrf>, after rounding, is outside the range of the specified output an execution error will be generated and the corresponding error number will be placed in the Execution Error Register, 105 (Maximum delta Amps value exceeded), if the value is too large or 108 (Minimum delta amp value exceeded) if the value is too small.

**DELTAV?** Sequential command  
Operation complete message generated immediately after <rmt> is sent.  
Returns the delta voltage value in Volts in <nr2> numeric format. The syntax of the response is

DELTAV <nr2><rmt>

*Example:* If the delta voltage is 0.55 Volts the response to the command  
DELTAV? will be DELTAV 0.55<rmt>

**DELTAI?** Sequential command  
Operation complete message generated immediately after <rmt> is sent.  
Returns the delta current value in Amps in <nr2> numeric format. The syntax of the response is

DELTAI <nr2><rmt>

*Example:* If the delta current is 0.550 Amps the response to the command  
DELTAI? will be DELTAI 0.550<rmt>

**INCVV** Sequential command  
Operation complete message generated immediately after execution.  
Increment the output voltage by the delta voltage value and verify that the voltage is within  $\pm 3$  counts or 5% of the target value. If the value of the output voltage is outside the range for the specified output the value is set to the maximum value allowed, no error is generated.

**INCV** Sequential command  
Operation complete message generated immediately after execution.  
This command is identical to INCVV above except that no verification of the output voltage is performed, thus saving the possible 500ms required to read back the output voltage. This is useful when it is known that the slew time will be short or during constant current operation.

**DECVV** Sequential command  
Operation complete message generated immediately after execution.  
Decrement the output voltage by the delta voltage value and verify that the voltage is within  $\pm 3$  counts or 5% of the target value. If the value of the output voltage is outside the range for the specified output the value is set to the minimum value allowed, no error is generated.

**DECV** Sequential command  
Operation complete message generated immediately after execution.  
This command is identical to DECVV above except that no verification of the output voltage is performed, thus saving the possible 500ms required to read back the output voltage. This is useful when it is known that the slew time will be short or during constant current operation.

**INCI** Sequential command  
Operation complete message generated immediately after execution.  
Increment the set current by the delta current value. If the value of the set current is outside the range for the specified output the value is set to the maximum value allowed, no error is generated.

DECI	<p>Sequential command</p> <p>Operation complete message generated immediately after execution.</p> <p>Decrement the set current by the delta current value. If the value of the set current is outside the range for the specified output the value is set to the minimum value allowed, no error is generated.</p>
POWER	<p>Sequential command</p> <p>Operation complete message generated immediately after &lt;rmt&gt; is sent.</p> <p>Returns the power being output from the instrument, in watts, in &lt;nr2&gt; numeric format. The syntax of the response is</p> <p style="text-align: center;">&lt;nr2&gt;W&lt;rmt&gt;</p> <p><i>Example:</i> If the output power is 175.3 watts the response to the command POWER? will be</p> <p style="text-align: center;">175.3W&lt;rmt&gt;</p>
OP <nrf>	<p>Sequential command</p> <p>Operation complete message generated immediately after execution.</p> <p>Sets the output status ON or OFF. If the value of &lt;nrf&gt;, after rounding, is 0 the output status will be set to OFF if 1 the output status will be ON. If the value of &lt;nrf&gt; is not 0 or 1 execution error 119 (Value out of range) will be generated.</p>
DAMPING <nrf>	<p>Sequential command</p> <p>Operation complete message generated immediately after execution.</p> <p>Sets the current meter damping to OFF or ON. If the value of &lt;nrf&gt;, after rounding, is 0 the meter damping will be set to OFF, if 1 the meter damping will be set to ON. If the value of &lt;nrf&gt; is not 0 or 1 execution error 119 (Value out of range) will be generated.</p>
LSR?	<p>Sequential command</p> <p>Operation complete message generated immediately after &lt;rmt&gt; is sent.</p> <p>Returns the value in the Limit Event Status Register in &lt;nr1&gt; numeric format. The register is then cleared. The syntax of the response is</p> <p style="text-align: center;">&lt;nr1&gt;&lt;rmt&gt;</p> <p><i>Example:</i> If the Limit Event Status Register contains 01000001b the response to LSR? will be</p> <p style="text-align: center;">65&lt;rmt&gt;</p>
LSE <nrf>	<p>Sequential command</p> <p>Operation complete message generated immediately after execution.</p> <p>Set the Limit Event Status Enable Register to the value of &lt;nrf&gt;. If the value of &lt;nrf&gt;, after rounding, is less than 0 or greater than 255 an execution error is generated and error number 119 (Value out of range) is placed in the Execution Error Register.</p>
LSE?	<p>Sequential command</p> <p>Operation complete message generated immediately after &lt;rmt&gt; is sent.</p> <p>Returns the value in the Limit Event Status Enable Register in &lt;nr1&gt; numeric format. The syntax of the response is</p> <p style="text-align: center;">&lt;nr1&gt;&lt;rmt&gt;</p> <p><i>Example:</i> If the Limit Event Status Enable Register contains 01000001b the response to LSE? will be</p> <p style="text-align: center;">65&lt;rmt&gt;</p>

QER?	<p>Sequential command</p> <p>Operation complete message generated immediately after &lt;rmt&gt; is sent.</p> <p>Returns the value in the Query Error Register in &lt;nr1&gt; numeric format. The register is then cleared. The syntax of the response is</p> <p style="text-align: center;">&lt;nr1&gt;&lt;rmt&gt;</p>
BUZZER <nrf>	<p>Sequential command</p> <p>Operation complete message generated immediately after execution.</p> <p>Sets the buzzer status to ON or OFF. If the value of &lt;nrf&gt;, after rounding, is 0 the buzzer status will be set to OFF, if 1 the buzzer status will be set to ON. If the value of &lt;nrf&gt; is not 0 or 1 execution error 119 (Value out of range) will be generated.</p>
BUZZ	<p>Sequential command.</p> <p>Operation complete message generated immediately after execution.</p> <p>Sounds the buzzer and sets the buzzer status to ON.</p>
LRN #0<Indefinite Length Binary Block data><pmt>	<p>Sequential command. (†)</p> <p>Operation complete message generated immediately after execution.</p> <p>Install all instrument settings from a previous *LRN? query. The response from a *LRN? command is formatted such that the complete message may be returned to the instrument at any time to restore the settings in effect when the *LRN? command was issued.</p> <p>The scope of the LRN command is as follows;</p> <p>The output is set to the values of Volts, current, OVP, delta V and delta A in the data block.</p> <p>The output status is set to the value in the data block.</p>
STO?	<p>Sequential command. (†)</p> <p>Operation complete message generated immediately after &lt;rmt&gt; is sent.</p> <p>Returns the contents of the stores in the instrument as an Indefinite Length Binary Block. The block is prefixed with the STO command and may thus be returned to the instrument to re-install the stored settings.</p> <p>The syntax of the response is</p> <p style="text-align: center;">STO #0&lt;Indefinite Length Binary Block data&gt;&lt;rmt&gt;</p> <p>The size of the data block is instrument type dependent. The settings in the instrument are not affected by execution of the STO? command.</p>
STO #0<Indefinite Length Binary Block data><rmt>	<p>Sequential command (†)</p> <p>Operation complete message generated immediately after execution.</p> <p>Install all stored data from a previous STO? query. The response from a STO? command is formatted such that the complete message may be returned to the instrument at any time to restore the data in effect when the STO? command was issued. The instrument settings are not affected by the STO command but the contents of the stores are completely updated.</p>

## Remote Command Summary - Common Commands

*CLS	Clear Status.
*ESE <nrf>	Set the Standard Event Status Enable Register to the value of <nrf>.
*ESE?	Returns the value in the Standard Event Status Enable Register.
*ESR?	Returns the value in the Standard Event Status Register.
*IDN?	Returns the instrument identification.
*IST?	Returns ist local message.
*LRN?	Returns the complete set up of the instrument.
*OPC	Sets the Operation Complete bit in the Standard Event Status Register.
*OPC?	Returns the Operation Complete status.
*PRE <nrf>	Set the Parallel Poll Enable Register to the value <nrf>.
*PRE?	Returns the value in the Parallel Poll Enable Register.
*RCL <nrf>	Recall Settings from store <nrf>.
*RST	Resets the instrument.
*SRE <nrf>	Set the Service Request Enable Register to <nrf>.
*SRE?	Returns the value of the Service Request Enable Register.
*STB?	Returns the value of the Status Byte Register.
SAV<nrf>	Save settings to store number <nrf>.
*TST?	Examine the state of the FLT bit in the Status byte register and return the result.
*WAI	Wait for operation complete true.

## Remote Command Summary - Other commands

V <nrf>	Set the output voltage to <nrf>.
VV <nrf>	Set the output voltage to <nrf> and verify.
I <nrf>	Set current limit to <nrf>.
OVP <nrf>	Set OVP to <nrf>.
V?	Returns the set voltage in Volts.
I?	Returns the current limit in Amps.
OVP?	Returns the OVP value in Volts.
VO?	Reads and returns the voltage in Volts.
IO?	Reads and returns the output current in Amps.
DECI	Decrement the set current by the delta current value.
DECV	Decrement the output voltage by the delta voltage value.
DECVV	Decrement the output voltage by the delta voltage value and verify.
DELTAI <nrf>	Set delta Amps to <nrf>.
DELTAV <nrf>	Set delta voltage to <nrf>.
DELTAI?	Returns the delta current value in Amps.
DELTAV?	Returns the delta voltage value in Volts.
INCI	Increment the set current by the delta current value.
INCV	Increment the output voltage by the delta voltage value.
INCVV	Increment the output voltage by the delta voltage value and verify.
POWER?	Returns the power being output from the instrument, in Watts.
OP <nrf>	Set the output status ON or OFF.
DAMPING <nrf>	Sets the meter damping to OFF or ON.
LSR?	Returns the value in the Limit Event Status Register.
LSE <nrf>	Set the Limit Event Status Enable Register to the value of <nrf>.
LSE?	Returns the value in the Limit Event Status Enable Register.
EER?	Returns the value in the Execution Error Register.
QER?	Returns the value in the Query Error Register.
BUZZER <nrf>	Sets the buzzer status to ON or OFF.
BUZZ	Sounds the buzzer and sets the buzzer status to ON.
LRN #0< Indefinite Length Binary Block data><pmt>	Install all stored data from a previous STO? query.
STO?	Returns the contents of the stores.
STO #0<Indefinite Length Binary Block data><pmt>	Install all stored data from a previous STO? query.



**TENMA<sup>®</sup>**  
**TEST EQUIPMENT**  
405 Pioneer Blvd.  
Springboro, Ohio 45066

Book Part No. 48511-0450 Issue 2