

Fiber Optic GaAlAs LED in SMA Receptacle Types OPF371A, OPF371B, OPF371C, OPF371D

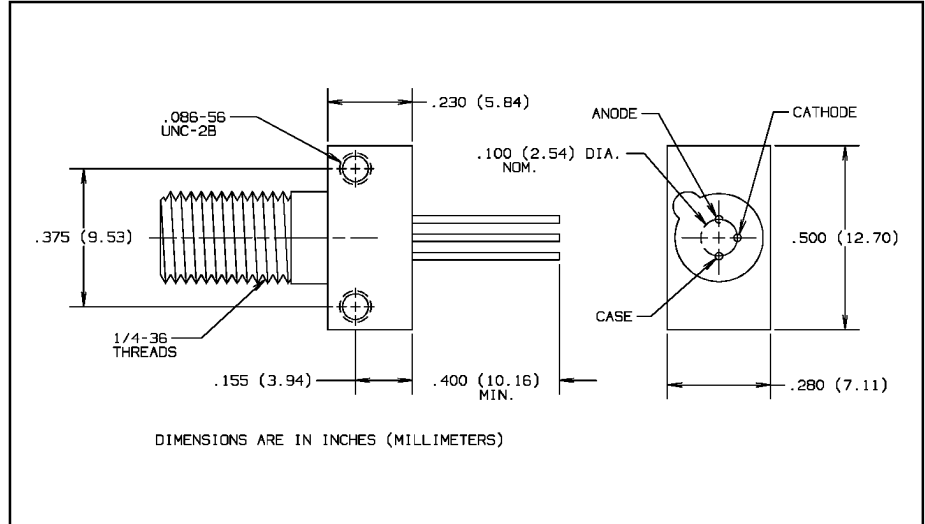
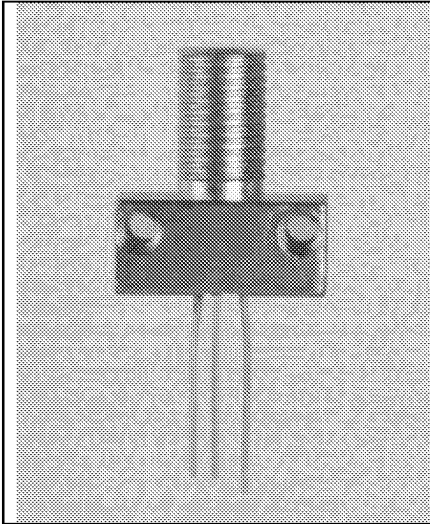

Features

- Component pre-mounted and ready to use
- Pre-tested with fiber to assure performance
- Popular SMA style receptacle

Description

The OPF371 series LED consists of a low cost plastic cap LED, pre-mounted and aligned in an SMA receptacle. This configuration is designed for PC board or panel mounting. Includes lock washer and jam nut, two 2-56 screws, and a dust cap.

The LED's are designed to interface with multimode optical fibers from 50/125 to 200/300 microns.

Absolute Maximum Ratings ($T_A = 25^\circ\text{C}$ unless otherwise noted)

Reverse Voltage	1.0 V
Continuous Forward Current	100 mA ⁽⁴⁾
Storage Temperature Range	-55° C to +100° C
Operating Temperature Range	-40° C to +85° C
Lead Soldering Temperature [1/16 inch (1.6 mm) from case for 5 sec. with soldering iron]	240° C ⁽¹⁾

Notes:

- (1) RMA flux is recommended. Duration can be extended to 10 sec. max when flow soldering.
- (2) Graded index fiber, 50 μm core, N.A. = 0.20.
- (3) To convert radiant power output to dBm, use the following expression: $\text{dBm} = 10 \log (\mu\text{W}/1000)$.
- (4) Derate linearly @ 1.0 mA/° C above 25° C.
- (5) Prebias @ 5 mA current.

LED Burn-in

All LED's are subject to 100% burn-in testing. Test conditions are 96 hours at 100 mA continuous current in 25° C ambient.

TYPICAL COUPLED POWER into OPTICAL FIBER

Typical Coupled Power $I_F = 100 \text{ mA @ } 25^\circ\text{C}$						
Fiber	Refractive Index	N.A.	OPF371D	OPF371C	OPF371B	OPF371A
50/125 μm	Graded	0.20	7.5 μW	12.5 μW	19 μW	29 μW
62.5/125 μm	Graded	0.28	27 μW	35 μW	51 μW	89 μW
100/140 μm	Graded	0.29	60 μW	87 μW	129 μW	200 μW
200/300 μm^*	Step	0.41	320 μW	463 μW	606 μW	750 μW

*PCS - Plastic Clad Silica

Types OPF371A, OPF371B, OPF371C, OPF371D

Electrical Characteristics ($T_A = 25^\circ\text{C}$ unless otherwise noted)

SYMBOL	PARAMETER	MIN	TYP	MAX	UNITS	TEST CONDITIONS	
P_O	Radiant Power Output	OPF371D	5.0	7.5		μW	$I_F = 100\text{ mA}^{(2)}$
		OPF371C	10.0	12.5			
		OPF371B	15.0	19.0			
		OPF371A	25.0	29.0			
V_F	Forward Voltage		1.8	2.0	V	$I_F = 100\text{ mA}$	
λ_p	Peak Output Wavelength	830	850	870	nm	$I_F = 50\text{ mA}$	
B	Spectral Bandwidth Between Half Power Points		35		nm	$I_F = 50\text{ mA}$	
t_r	Output Rise Time		6.0	8.0	ns	$I_F = 100\text{ mA}, 10\%-90\%^{(5)}$	
t_f	Output Fall Time		6.0	10.0	ns	$I_F = 100\text{ mA}, 90\%-10\%^{(5)}$	

Typical Performance Curves

