

HITACHI

KAOHSIUNG HITACHI
ELECTRONICS CO.,LTD
P.O. BOX 26-27
2,13TH EAST ST. K.E.P.Z.
KAOHSIUNG TAIWAN R.O.C.
TEL:(07) 8215811 (7 LINE)
FAX:(07) 8215815

FOR MESSRS. _____

DATE. Jun.04,2004

CUSTOMER'S ACCEPTANCE SPECIFICATIONS

SP14Q003 CONTENTS

No.	ITEM	SHEET No.	PAGE
1	COVER	7B64PS 2701-SP14Q003-3	1-1/1
2	RECORD OF REVISION	7B64PS 2702- SP14Q003-3	2-1/1
3	GENERAL SPECIFICATION	7B64PS 2703- SP14Q003-3	3-1/1
4	ABSOLUTE MAXIMUM RATINGS	7B64PS 2704- SP14Q003-3	4-1/1
5	ELECTRICAL CHARACTERISTICS	7B64PS 2705- SP14Q003-3	5-1/1
6	OPTICAL CHARACTERISTICS	7B64PS 2706- SP14Q003-3	6-1/2~2/2
7	BLOCK DIAGRAM	7B64PS 2707- SP14Q003-3	7-1/1
8	INTERFACE TIMING CHART	7B64PS 2708- SP14Q003-3	8-1/3~3/3
9	OUTLINE DIMENSIONS	7B63PS 2709- SP14Q003-3 7B64PS 2709- SP14Q003-3	9-1/2 9-2/2
10	APPEARANCE STANDARD	7B64PS 2710- SP14Q003-3	10-1/3~3/3
11	PRECAUTION IN DESIGN	7B64PS 2711- SP14Q003-3	11-1/3~3/3
12	DESIGNATION OF LOT MARK	7B64PS 2712- SP14Q003-3	12-1/1
13	PRECAUTION FOR USE	7B64PS 2713- SP14Q003-3	13-1/1

* When products will be discontinued , customers will be informed by HITACHI
with twelve months prior announcement.

ACCEPTED BY: _____

PROPOSED BY: Jimmy H.O

KAOHSIUNG HITACHI ELECTRONICS CO.,LTD.	Sh. No.	7B64PS 2701- SP14Q003-3	PAGE	1-1/1
---	------------	-------------------------	------	-------

RECORD OF REVISION

DATE	SHEET No.	SUMMARY																					
Mar.12,'04	7B64PS 2708- SP14Q003-2 Page 8-3/3	8.3 TIMING OF POWER SUPPLY AND INTERFACE SIGNAL Added tDLD min. → 50 Revised tCH max. 50 → 30																					
Jun.04,'04	7B64PS 2705- SP14Q003-3 Page 5-1/1	5.1 ELECTRICAL CHARACTERISTICS Added																					
		<table border="1" style="width: 100%; border-collapse: collapse;"> <thead> <tr> <th style="width: 30%;">ITEM</th> <th style="width: 15%;">SYMBOL</th> <th style="width: 10%;">MIN.</th> <th style="width: 10%;">TYP.</th> <th style="width: 10%;">MAX</th> </tr> </thead> <tbody> <tr> <td>Power Supply Voltage Logic</td> <td>VDD-VSS</td> <td>3.2</td> <td>3.3</td> <td>3.4</td> </tr> <tr> <td rowspan="3">Recommend LC Driving Voltage</td> <td rowspan="3">VDD-V0</td> <td>22.5</td> <td>23.5</td> <td>24.5</td> </tr> <tr> <td>21.3</td> <td>22.3</td> <td>23.3</td> </tr> <tr> <td>20.6</td> <td>21.6</td> <td>22.6</td> </tr> </tbody> </table>	ITEM	SYMBOL	MIN.	TYP.	MAX	Power Supply Voltage Logic	VDD-VSS	3.2	3.3	3.4	Recommend LC Driving Voltage	VDD-V0	22.5	23.5	24.5	21.3	22.3	23.3	20.6	21.6	22.6
		ITEM	SYMBOL	MIN.	TYP.	MAX																	
		Power Supply Voltage Logic	VDD-VSS	3.2	3.3	3.4																	
Recommend LC Driving Voltage	VDD-V0	22.5	23.5	24.5																			
		21.3	22.3	23.3																			
		20.6	21.6	22.6																			
5.2 ELECTRICAL CHARACTERISTICS OF BACKLIGHT Added Note1~4																							
7B64PS 2706- SP14Q003-3 Page 6-2/2	6.2 OPTICAL CHARACTERISTICS OF BACKLIGHT Added The LCD driving voltage should be adjusted at the voltage where the peak contrast is obtained.																						
7B64PS 2710- SP14Q003-3 Page 10-1/3	10.1 APPEARANCE INSPECTION CONDITION Revised 45°→25°																						

3. GENERAL SPECIFICATIONS

(1) Part Name	SP14Q003
(2) Outer Dimensions	167.0(W)mm x 109.0(H)mm x 10.0(D)mm(max.)
(3) Effective Display Area	120 mm min. x 89 mm min.
(4) Dot Size	0.345(W)min. x 0.345(H)min.
(5) Dot Pitch	0.360(W)mm x 0.360(H)mm
(6) Dot Number (Resolution)	320 (W) x 240 (H)
(7) Duty Ratio	1/240
(8) LCD Type	Blue type (negative type) The upper polarizer is anti-glare type. The bottom polarizer is transmissive type.
(9) Viewing Direction	6 O'clock
(10) Backlight Type	Cold cathode fluorescent lamp.

4. ABSOLUTE MAXIMUM RATINGS

4.1 ELECTRICAL ABSOLUTE MAXIMUM RATINGS.

VSS=0V:STANDARD

ITEM	SYMBOL	MIN.	MAX.	UNIT	COMMENT
Power Supply for Logic	VDD-VSS	0	6	V	
Power Supply for LC Driving	VDD-VEE	0	27.5	V	
Input Signal Voltage	V_i	-0.3	VDD+0.3	V	(Note 1)
Input Signal Current	I_i	0	1	A	
Static Electricity	-	-	100	-	(Note 2)

Note 1 : \overline{DOFF} , FLM , LOAD , CP , D0~D3.

Note 2 : Make certain you are grounded when handling LCM.

4.2 ENVIRONMENTAL ABSOLUTE MAXIMUM RATINGS.

ITEM	OPERATING		STORAGE		COMMENT
	MIN.	MAX.	MIN.	MAX.	
Ambient Temperature	0°C	50°C (Note 5)	-20°C	60°C	(Note 2,3,6)
Humidity	(Note 1)		(Note 1)		Without Condensation
Vibration	-	2.45m/s ² (0.25G)	-	11.76m/s ² (1.2G) (Note 5)	(Note 4)
Shock	-	29.4m/s ² (3 G)	-	490.0m/s ² (50 G) (Note 5)	XYZ Directions
Corrosive Gas	Not Acceptable		Not Acceptable		

Note 1 : $T_a \leq 40^\circ\text{C}$: 85%RH max.

$T_a > 40^\circ\text{C}$: Absolute humidity must be lower than the humidity of 85%RH at 40°C

Note 2 : T_a at $-20^\circ\text{C} < 48\text{h}$, at $60^\circ\text{C} < 168\text{h}$.

Note 3 : Background color changes slightly depending on ambient temperature.
The phenomenon is reversible.

Note 4 : 5Hz~100Hz (Except resonance frequency and X,Y,Z each direction within 1h)

Note 5 : This module should be operated normally after finish the test.

Note 6 : When LCM will be operated at 0°C , the life time of CFL will be reduced.

Please make sure that characteristics of the inverter meet the CFL specification.

KAOHSIUNG HITACHI ELECTRONICS CO.,LTD.	DATE	Jun.04,'04	Sh. No.	7B64PS 2704-SP14Q003-3	PAGE	4-1/1
---	------	------------	------------	------------------------	------	-------

5. ELECTRICAL CHARACTERISTICS

5.1 ELECTRICAL CHARACTERISTICS

ITEM	SYMBOL	CONDITION	MIN.	TYP.	MAX.	UNIT
Power Supply Voltage for Logic	VDD-VSS	-	4.75	5.0	5.25	V
			3.2	3.3	3.4	
Power Supply Voltage for LC Driving	VEE-VSS	-	-23.1	-22.0	-20.9	V
Input Signal Voltage (Note 1)	Vi	H LEVEL	0.8VDD	-	VDD	V
		L LEVEL	0	-	0.2VDD	V
Power Supply Current for Logic (Note 2)	IDD	VDD-VSS=5.0V VEE-VSS= -22.0V	-	6.0	-	mA
Power Supply Current for LC Driving (Note 2)	IEE	VDD-VSS=5.0V VEE-VSS= -22.0V	-	5.0	-	mA
Recommended LC Driving Voltage (Note 3)	VDD-V0	Ta= 0°C , $\phi = 0^\circ$	22.5	23.5	24.5	V
		Ta=25°C , $\phi = 0^\circ$	21.3	22.3	23.3	V
		Ta=50°C , $\phi = 0^\circ$	20.6	21.6	22.6	V
Frame Frequency (Note 4)	fFLM	-	70	75	80	Hz

Note 1 : $\overline{\text{DOFF}}$, FLM , LOAD , CP , D0~D3.

Note 2 : FLM=75Hz , test pattern is all "Q".

VDD-V0=22.3V , Ta=25°C

Note 3 : Recommended LC driving voltage may fluctuate about $\pm 1.0V$ by each module.
Test pattern is all "Q"

Note 4 : Please set the frame frequency so as to avoid flicker and rippling on the display.

5.2 ELECTRICAL CHARACTERISTICS OF BACKLIGHT

ITEM	SYMBOL	MIN.	TYP.	MAX.	UNIT	NOTE
Lamp Voltage	VL	-	300	-	Vrms	Ta=25°C
Frequency	FL	-	70	85	kHz	Ta=25°C
Lamp Current	IL	4	5	6	mArms	Ta=25°C
Starting Discharge Voltage	VS	(1000)	-	-	Vrms	Ta=25°C

Note 1 : Please make sure that your inverter is designed to meet the above specifications.

Note 2 : Starting discharge voltage is increased when LCM is operating at lower temperature , please check the characteristics of your inverter , so as to ensure discharge at low temperature.

Note 3 : Average life time of CFL will be decreased when LCM is operating at lower temperature.

Note 4 : Lower driving frequency of CFL inverter may cause mechanical noise of the backlight system .
Before designing the inverter , please consider the driving frequency of noise.

6. OPTICAL CHARACTERISTICS

6.1 OPTICAL CHARACTERISTICS

Ta=25°C (BACKLIGHT ON)

ITEM	SYMBOL	CONDITIONAL	MIN.	TYP.	MAX.	UNIT	NOTE
Viewing Area	$\phi 2-\phi 1$	$K \geq 2.0$	-	40	-	deg	1,2
Contrast Ratio	K	$\phi = 0^\circ, \theta = 0^\circ$	-	6	-	-	3
Response Time (Rise)	tr	$\phi = 0^\circ, \theta = 0^\circ$	-	120	-	ms	4
Response Time (Fall)	tf	$\phi = 0^\circ, \theta = 0^\circ$	-	150	-	ms	4

(Measure condition by HITACHI)

Note 1 : Definition of θ and ϕ

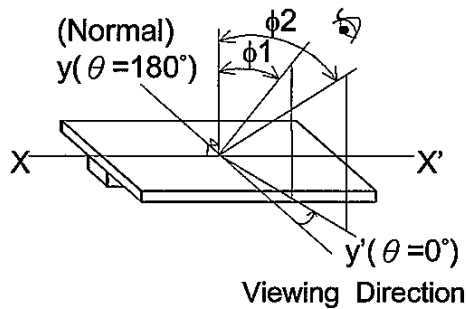

Note 3 : Definition of contrast "K"

$$K = \frac{\text{Brightness on Selected Dot (B1)}}{\text{Brightness on Non-Selected Dot (B2)}}$$

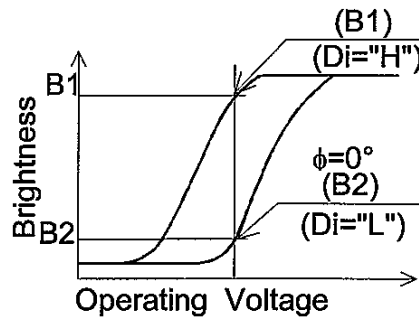

Note 2 : Definition of viewing angle $\phi 1$ and $\phi 2$.

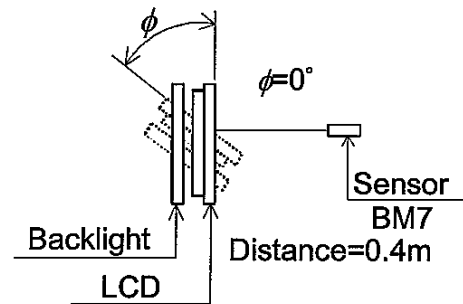
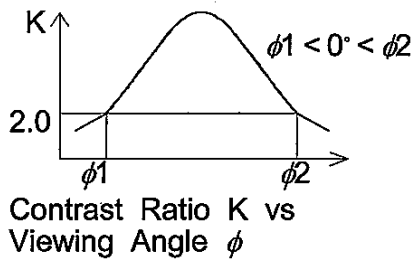

Note 4 : Definition of optical response

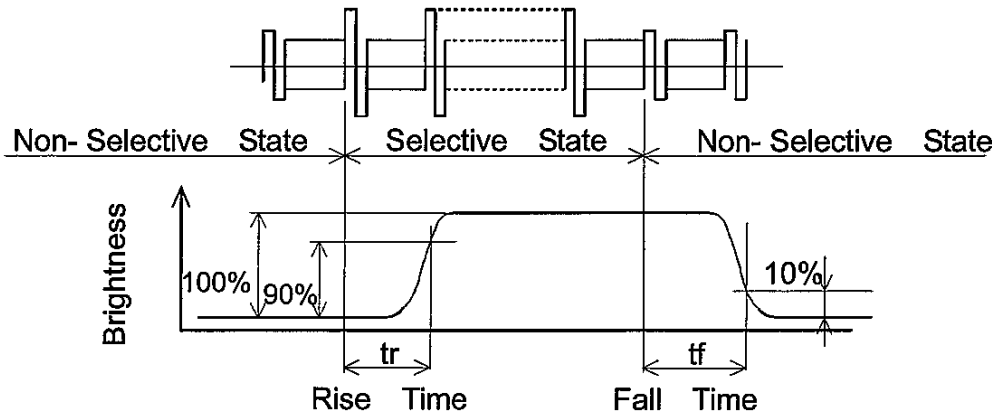

6.2 OPTICAL CHARACTERISTICS OF BACKLIGHT

ITEM	MIN.	TYP.	MAX.	UNIT	NOTE
Brightness	-	100	-	cd/m ²	IL=5mA (Note 1,2)
Rise Time	-	5	-	minute	IL=5mA Brightness 80%
Brightness Uniformity	-	-	±30	%	(Note 1,3)

CFL : Initial, Ta=25°C

Display data should be all "ON".

The LCD driving voltage should be adjusted at the voltage where the peak contrast is obtained.

Note 1 : Measurement after 10 minutes of CFL operating.

Note 2 : Brightness control : 100%

Note 3 : Measure of the following 9 places on the display.
Definition of the brightness tolerance.

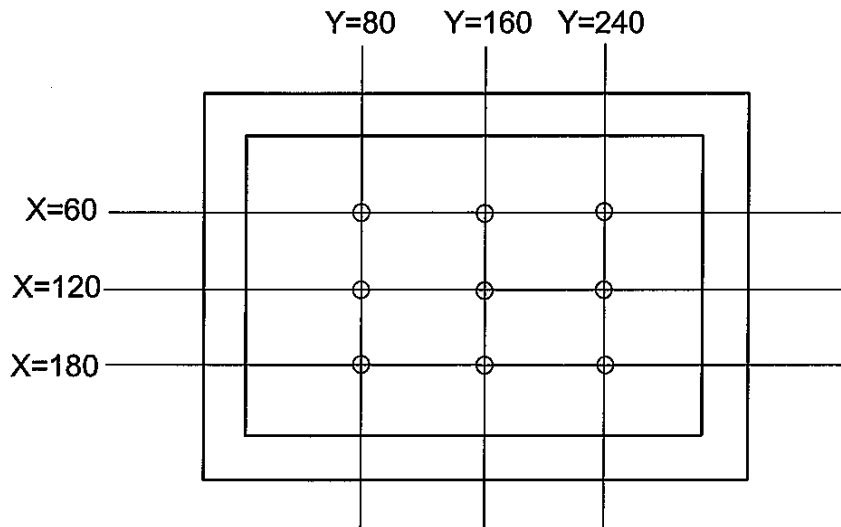

Definition of the brightness tolerance.

$$\left(\frac{\text{Max. or Min. Brightness} - \text{Average Brightness}}{\text{Average Brightness}} \right) \times 100$$

7. BLOCK DIAGRAM

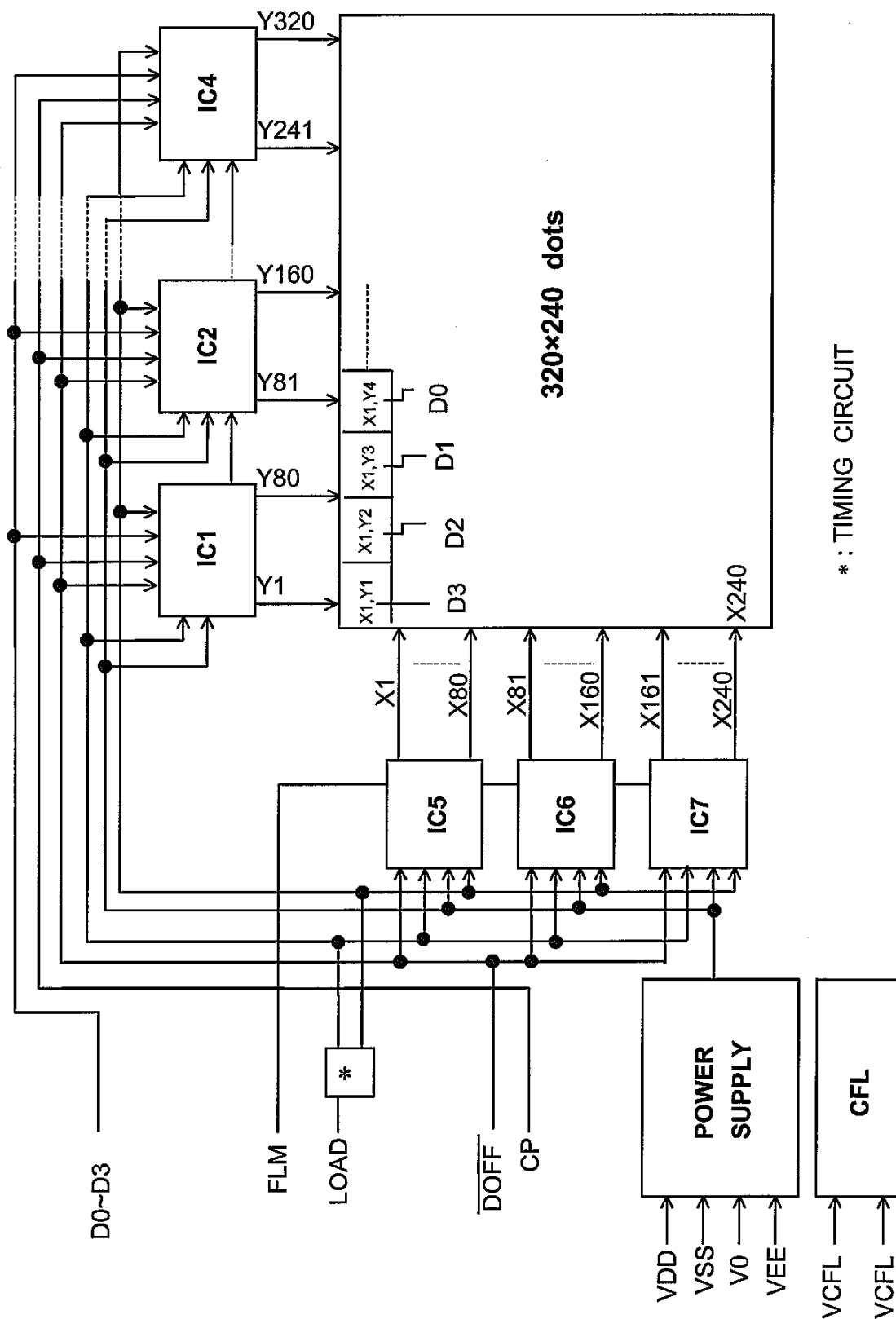

8. INTERFACE TIMING CHART

8.1 INTERFACE TIMING CHART

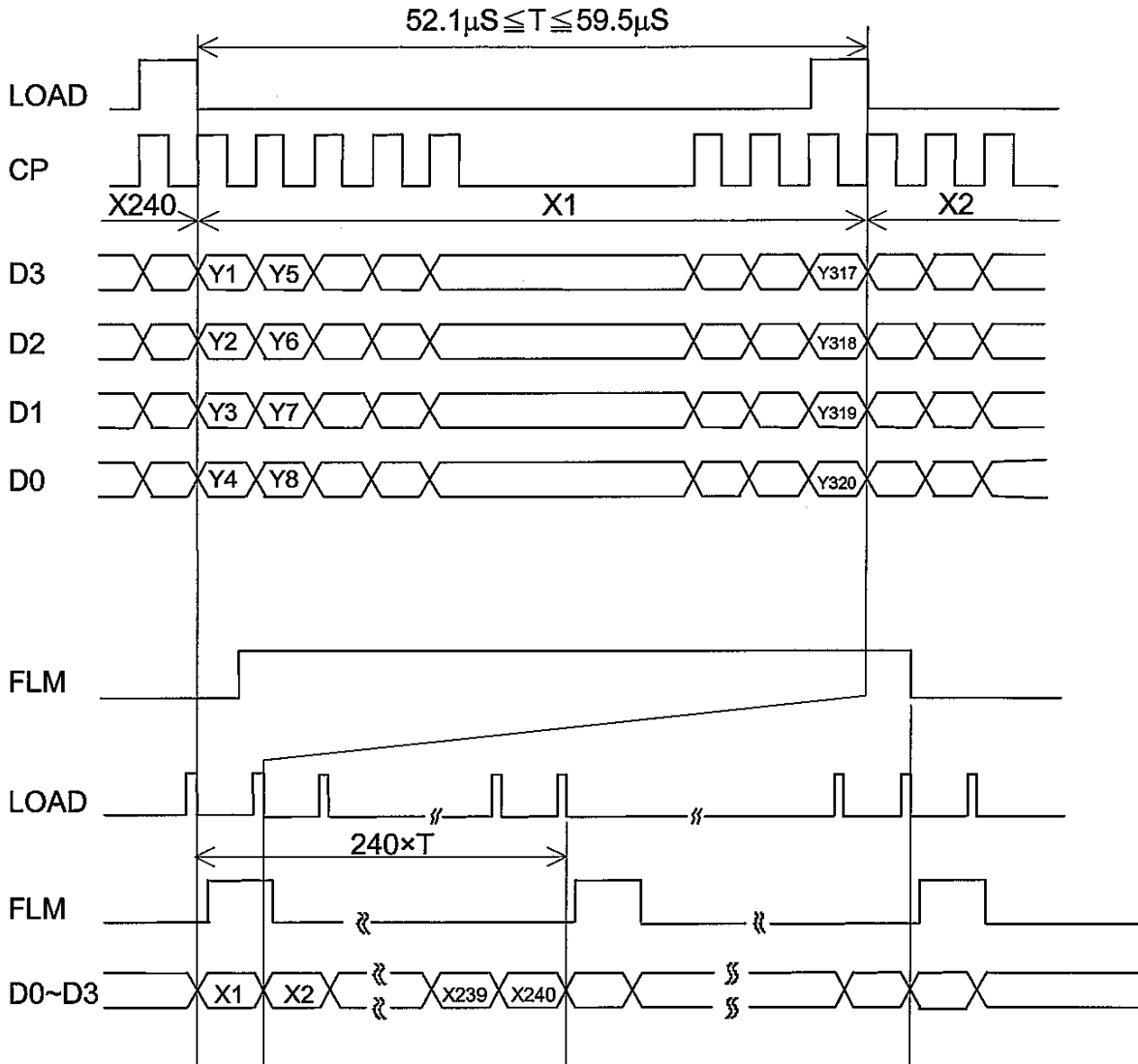

Downloaded from Elcodis.com electronic components distributor

8.2 TIMING CHARACTERISTICS

ITEM	SYMBOL	MIN.	TYP.	MAX.	UNIT
Clock Frequency	fCP	-	-	6.5	MHz
Clock Pulse Width	tw	63	-	-	ns
Clock Rise, Fall Time	tr,tf	-	-	20	ns
Data Set Up Time	tDSU	50	-	-	ns
Data Hold Time	tDHD	50	-	-	ns
Load Set Up Time	tLSU	80	-	-	ns
Load Clock Time	tLC	80	-	-	ns
"Frame" Set Up Time	tSETUP	100	-	-	ns
"Frame" Hold Time	tHOLD	100	-	-	ns
"Load" Pulse Width	tWC	125	-	-	ns

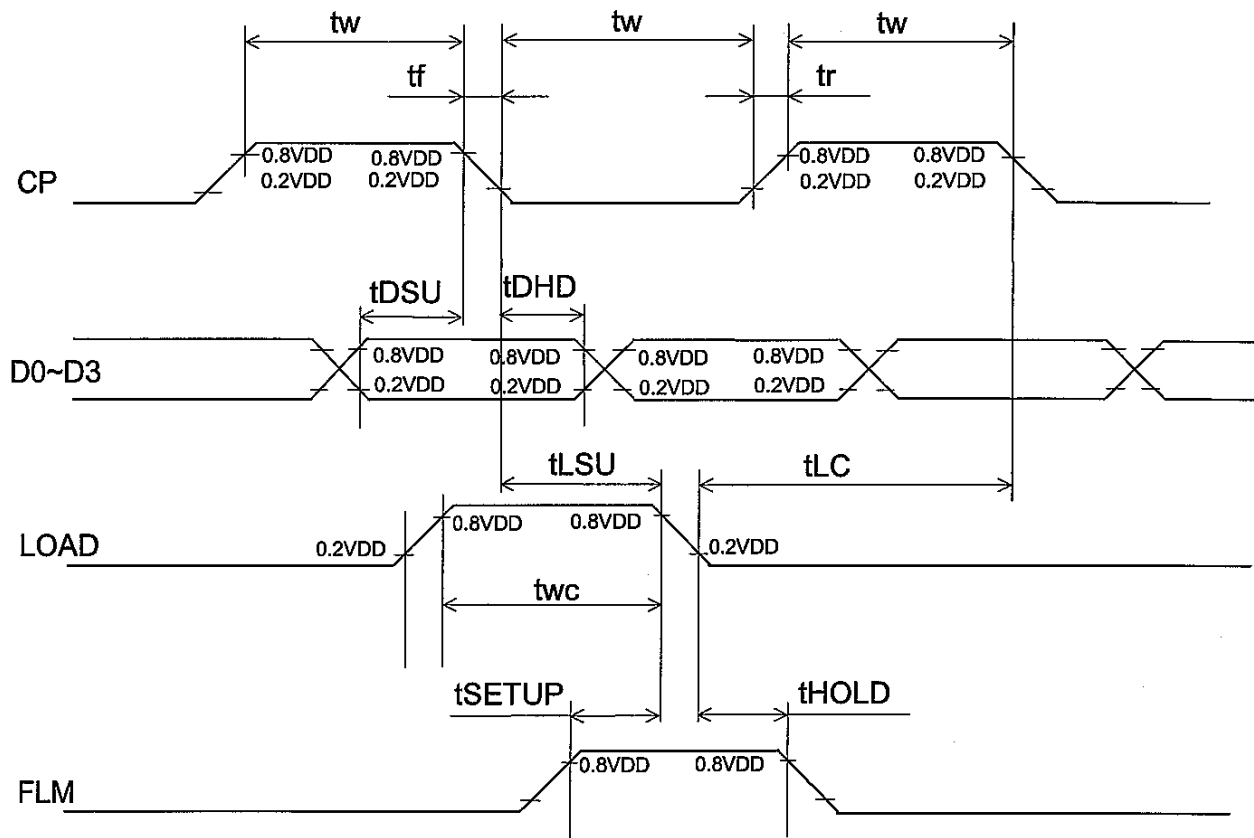

8.3 POWER ON/OFF TIMING SEQUENCE

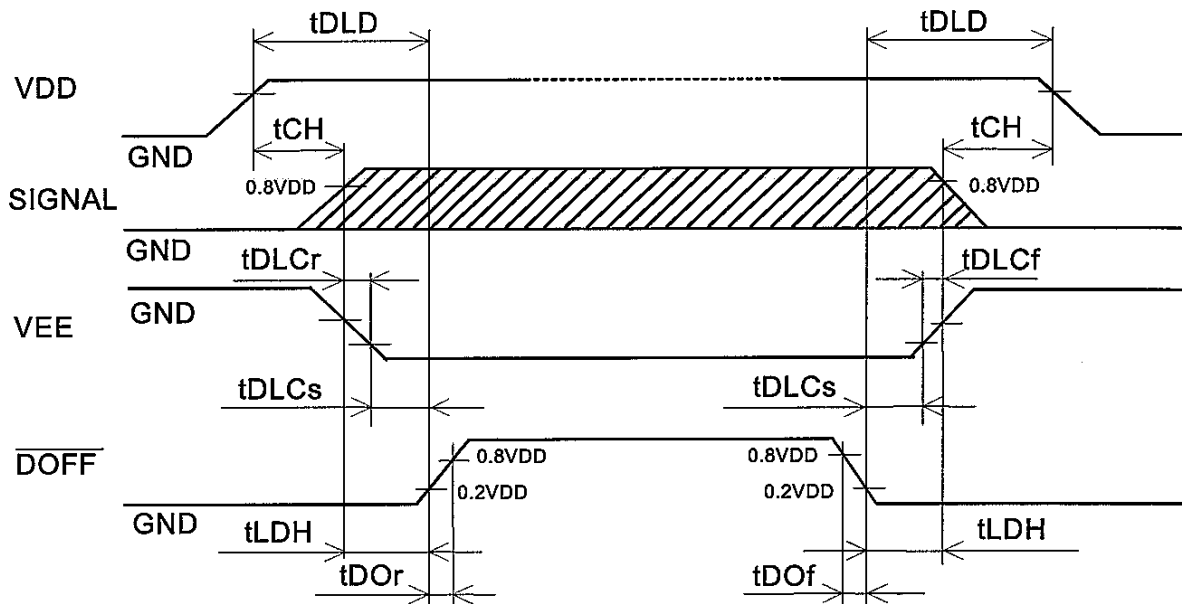

SYMBOL	MIN.	MAX.	UNIT	COMMENT
t_{DLd}	50	-	ms	(Note 1)
t_{CH}	0	30	ms	
t_{LDH}	0	-	ms	
t_{DOr}	-	100	ns	(Note 2)
t_{DOF}	-	100	ns	
t_{DLcR}	0	-	ms	
t_{DLcF}	0	-	ms	
t_{DLcS}	20	-	ms	

Note 1 Please keep the specified sequence because wrong sequence may cause permanent damage to the LCD panel.

Note 2 HITACHI recommends you to use \overline{DOFF} function.

Display quality may deteriorate if you don't use \overline{DOFF} function.

8.4 POWER SUPPLY FOR LCM

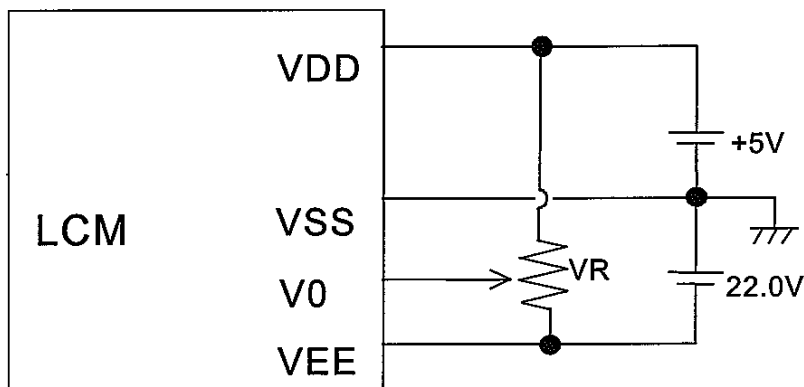

Note 1 : VR : 10kOHM

Note 2 : We recommend to ADD fuse (1A) to VDD line.

9. OUTLINE DIMENSIONS
9.1 OUTLINE DIMENSIONS

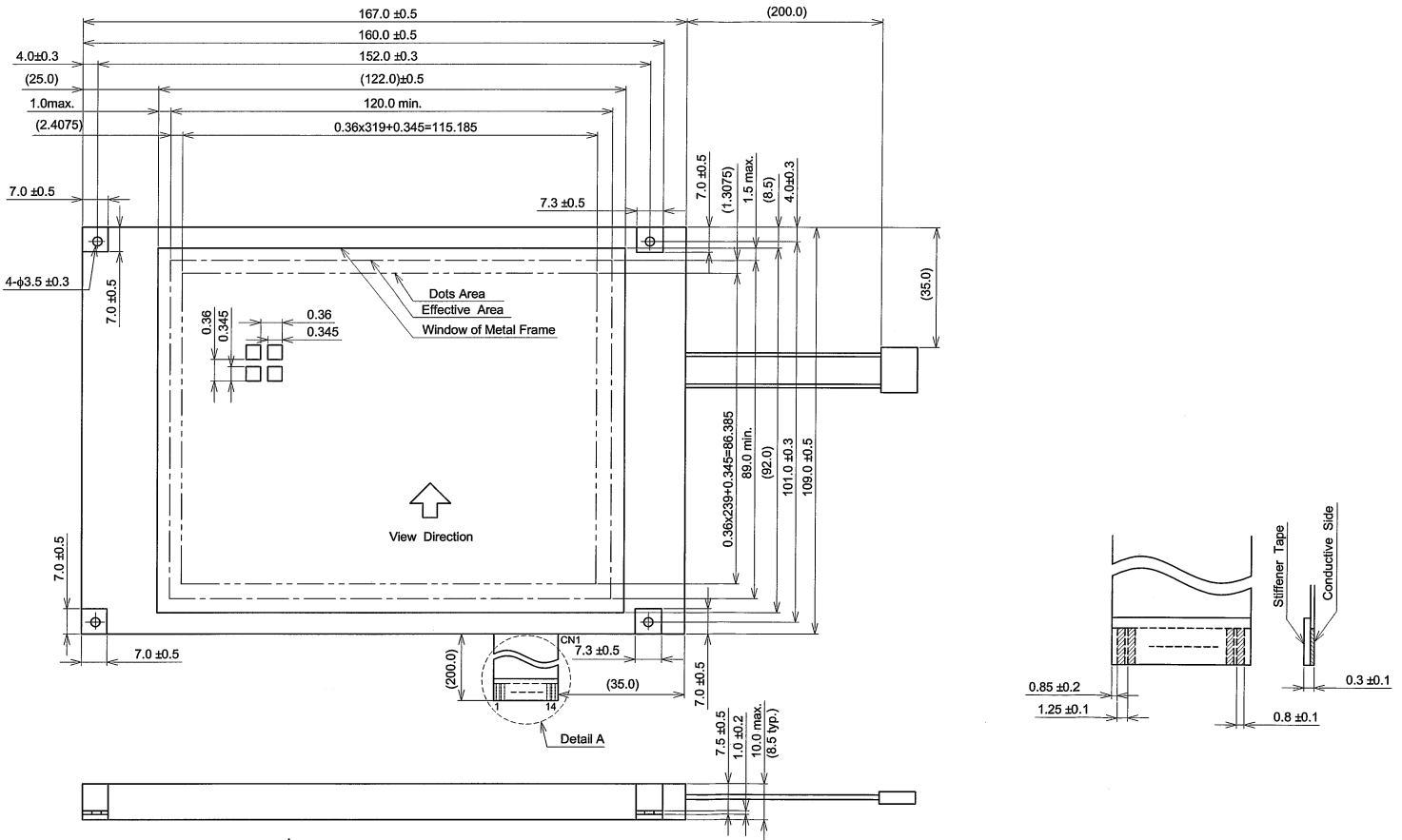

Note 1 : Measurement when adding 9.8×10^4 Pa at the measuring point.

Scale : NTS
Unit : mm

KAOHSIUNG HITACHI ELECTRONICS CO.,LTD.	DATE	Jun.04,'04	Sh. No.	7B63PS 2709-SP14Q003-3	PAGE	9-1/2
---	------	------------	------------	------------------------	------	-------

9.2 DISPLAY PATTERN

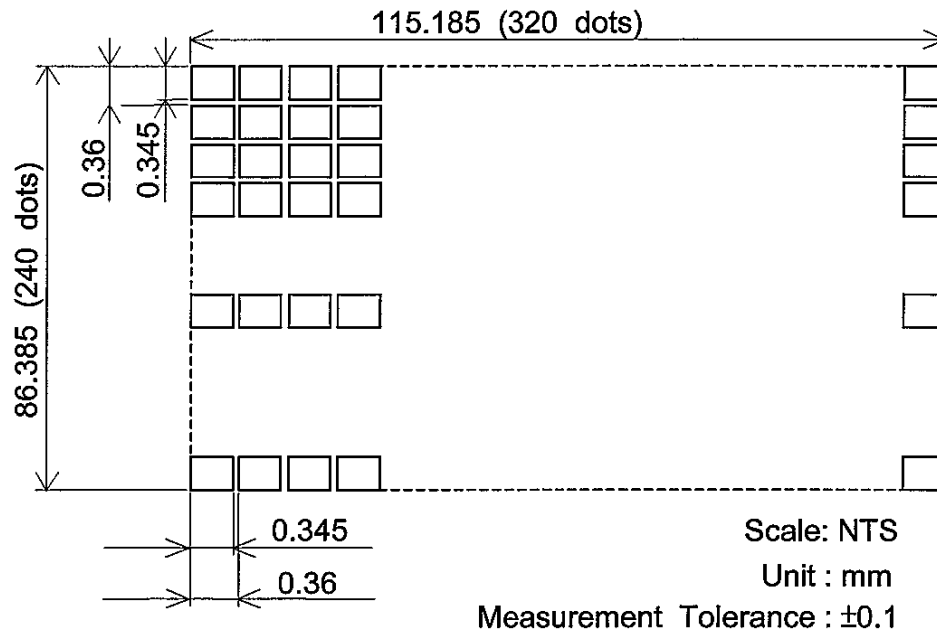

9.3 INTERFACE PIN CONNECTION

FFC : PITCH 1.25mm 14 PINS

INTERFACE	PIN No.	SIGNAL	LEVEL	FUNCTION	
LCM	CN1	1	D0	H/L	Display data
		2	D1		
		3	D2		
		4	D3		
	5	DOFF	H/L	H : ON / L : OFF	
	6	FLM	H	First line marker	
	7	N.C	-	-	
	8	LOAD	H→L	Data latch	
	9	CP	H→L	Data shift	
	10	VDD	-	Power supply for logic	
	11	VSS	-	GND	
	12	VEE	-	Power supply for LC	
	13	V0	-	Operating voltage LC driving	
	14	VSS	-	GND	

RECOMMEND SUITABLE CONNECTOR : (MOLEX) 5597-14APB

INTERFACE	PIN No.	SIGNAL	LEVEL	FUNCTION	
CFL	CN2	1	VCFL	-	Power supply for CFL
		2	N.C	-	-
		3	N.C	-	-
		4	VCFL	-	CFL GND

CFL I/F : J.A.E./IL - G - 4S -S3C2

10. APPEARANCE STANDARD

10.1 APPEARANCE INSPECTION CONDITIONS

Visual inspection should be done under the following condition.

- (1) The inspection should be done under in the dark room.
- (2) The CFL should be lighted with the prescribed inverter.
- (3) The distance between eyes of an inspector and the LCD module is 25cm.
- (4) The viewing zone is shown the figure .

Viewing angle $\leq 25^\circ$

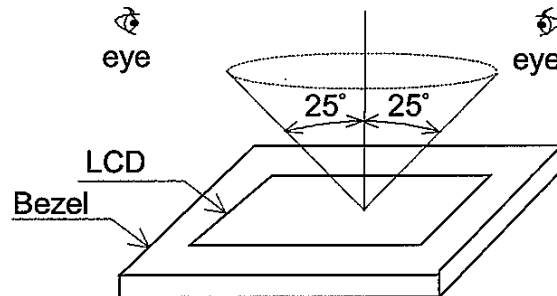

10.2 DEFINITION OF EACH ZONE

A zone : Within the viewing area specified at page 9-1/2 of this document.

B zone : Area between the edge line of LCD glass and the viewing area line specified at page 9-1/2 of this document.

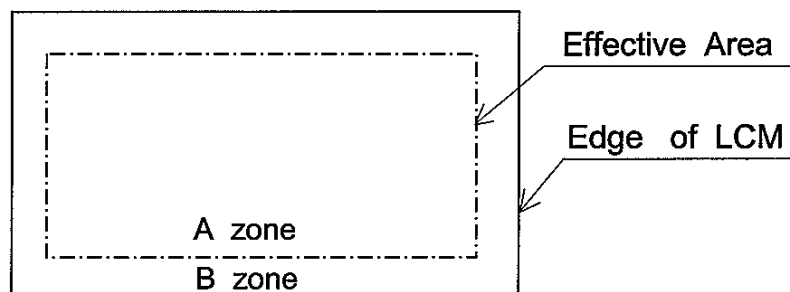

10.3 APPEARANCE SPECIFICATION

*) If a problem occurs in respect to any of these items ,
both parties (Customer and HITACHI) will discuss in more detail.

No.	ITEM	CRITERIA			A	B
L C D	Scratches	Distinguished one is not acceptable (to be judged by HITACHI limit sample)			*	-
	Dent	Same as Above			*	-
	Wrinkles in Polarizer	Same as Above			*	-
	Bubbles	Average Diameter D(mm)		Maximum Number Acceptable	O	-
	Wrinkles in Polarizer	$D \leq 0.2$		Ignore		
		$0.2 < D \leq 0.3$		12		
		$0.3 < D \leq 0.5$		3		
		$0.5 < D$		None		
	Stains, Foreign Materials, Dark Spot	Filamentous			O	-
		LENGTH L(mm)	WIDTH W(mm)	Maximum Number Acceptable		
		$L \leq 2.0$	$W \leq 0.03$	Ignore		
		$L \leq 3.0$	$0.03 < W \leq 0.05$	6		
		$L \leq 2.5$	$0.05 < W \leq 0.1$	1		
		Round			O	-
		Average Diameter D(mm)	Maximum Number Acceptable	Minimum Space		
		$D < 0.2$	Ignore	-		
		$0.2 \leq D < 0.33$	8	10mm		
		$0.33 \leq D$	None	-		
	The whole number		Filamentous + Round = 10		O	O
	Those wiped out easily are acceptable				O	O
Color Tone	To be judged by HITACHI limit sample			O	-	
Color Uniformity	Same as Above			O	-	
Pinhole	Average Diameter D(mm)		Maximum Number Acceptable	O	-	
	$D \leq 0.15$		Ignore			
	$0.15 < D \leq 0.3$		10			
	$D \leq 0.015$		Ignore			
Contrast Irregularity (Spot)	Average Diameter D(mm)	Contrast	Maximum Number Acceptable	O	-	
	$D \leq 0.25$	To be judged by HITACHI	Ignore			-
	$0.25 < D \leq 0.35$		10			20mm
	$0.35 < D \leq 0.5$		4			20mm
	$0.5 < D$		None			-

No.	ITEM	CRITERIA				A	B
		Width D(mm)	Length L(mm)	Maximum Number Acceptable	Minimum Space		
L C D	Contrast Irregularity (Line) (Filamentous)	$W \leq 0.25$	$L \leq 1.2$	2	20mm	O	-
		$W \leq 0.2$	$L \leq 1.5$	3	20mm		
		$W \leq 0.15$	$L \leq 2.0$	3	20mm		
		$W \leq 0.1$	$L \leq 3.0$	4	20mm		
		Total		6			
	Rubbing Scratch	To be judged by HITACHI standard				O	-

No.	ITEM	CRITERIA	
C F	Dark Spots, White Spots Foreign Materials (Spot)	$D \leq 0.4$	Ignore
		$D > 0.4$	None
L B /	Foreign Materials (Line)	$W \leq 0.2$ $L < 2.5$	≤ 1
		$W \leq 0.2$ $L > 2.5$	None
L	Scratches	$W > 0.2$	None
		$W \leq 0.1$	Ignore
		$0.1 < W \leq 0.2$ $L \leq 11.0$	≤ 1
		$0.1 < W \leq 0.2$ $L \geq 11.0$	None
		$W > 0.2$	None

Note 1 :

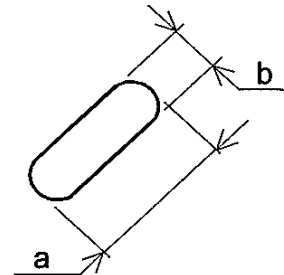
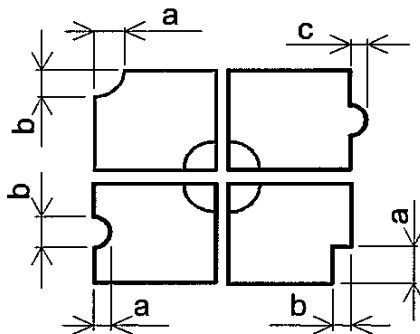

$$\frac{a+b}{2} = D \text{ Average diameter}$$

c Salient

Note 2 : Definition of length L and width W

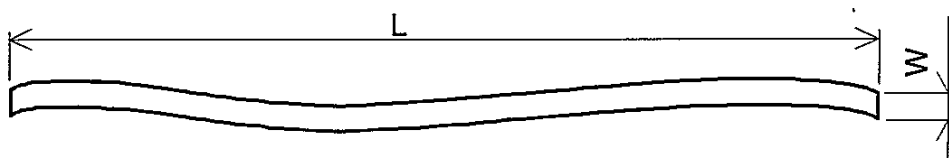

11. PRECAUTION IN DESIGN

11.1 LC DRIVING VOLTAGE (VEE) AND VIEWING ANGLE RANGE.

Setting VEE out of the recommended condition will be a cause for a change of viewing angle range.

11.2 PRECAUTIONS AGAINST STATIC CHARGE

As this module contains C-MOS LSIs, it is not strong against electrostatic discharge. Make certain that the operator's body is connected to the ground through a wrist band etc. And don't touch I/F pins directly.

11.3 POWER ON SEQUENCE

Input signals should not be applied to LCD module before power supply voltage is applied and reaches to specified voltage (VDD).

If above sequence is not kept, C-MOS LSIs of LCD modules may be damaged due to latch up problem.

11.4 PACKAGING

- (1) No. leaving product is preferable in the place of high humidity for a long period of time. For their storage in the place where temperature is 35 °C or higher, special care to prevent them from high humidity is required. A combination of high temperature and high humidity may cause them polarization degradation as well as bubble generation and polarizer peel-off. Please keep the temperature and humidity within the specified range for use and storage.
- (2) Since polarizers tend to be easily damaged, they should be handled full with care so as not to get them touched, pushed or rubbed.
- (3) As the adhesives used for adhering polarizers are made of organic substances which will be deteriorated by a chemical reaction with such chemicals as acetone, toluene, ethanol and isopropyl alcohol. The following solvents are recommended for use:
normal hexane
Please contact us when it is necessary for you to use chemicals.
- (4) Lightly wipe to clean the dirty surface with absorbent cotton waste or other soft material like chamois, soaked in the chemicals recommended without scrubbing it hardly. To prevent the display surface from damage and keep the appearance in good state, it is sufficient, in general, to wipe it with absorbent cotton.
- (5) Immediately wipe off saliva or water drop attached on the display area because its long period adherence may cause deformation or faded color on the spot.
- (6) Foggy dew deposited on the surface due to coldness will be caused for polarizer damage, stain and dirt on product. When necessary to take out the products from some place at low temperature for test, etc.
It is required for them to be warmed up in a container once at the temperature higher than that of room.
- (7) Touching the display area and contact terminals with bare hands and contaminating them are prohibited, because the stain on the display area and poor insulation between terminals are often caused by being touched by bare hands.
(Some cosmetics are detrimental to polarizers.)

KAOHSIUNG HITACHI ELECTRONICS CO.,LTD.	DATE	Jun.04,'04	Sh. No.	7B64PS 2711-SP14Q003-3	PAGE	11-1/3
---	------	------------	------------	------------------------	------	--------

(8) In general the quality of glass is fragile so that it tends periphery. Be careful not to give it sharp shock caused by dropping down, etc.

11.5 CAUTION FOR OPERATION

- (1) It is an indispensable condition to drive LCDs within the specified voltage limit since the higher voltage than the limit causes the shorter LCD life. An electrochemical reaction due to direct current causes LCDs undesirable deterioration, so that the use of direct current driver should be avoided.
- (2) Response time will be extremely delayed at lower temperature than the operating temperature range and on the other hand at higher temperature LCDs show dark blue color in them. However those phenomena do not mean malfunction or out of order with LCDs which will come back in the specified operating temperature range.
- (3) If the display area is pushed hard during operation, some font will be abnormally displayed but it resumes normal condition after turning off once.
- (4) A slight dew depositing on terminals is a cause for electrochemical reaction resulting in terminal open circuit. Usage under the relative condition of 40°C 50%RH or less is required.

11.6 STORAGE

In case of storing for a long period of time (for instance, for years) for the purpose of replacement use, the following ways are recommended.

- (1) Storage in a polyethylene bag with the opening sealed, so the fresh air will not be entered from outside.
- (2) Placing in a dark place where neither exposure to direct sunlight nor light is, keeping temperature in the range from 0 °C to 35 °C.
- (3) Storing with no touch on polarizer surface by anything else. (It is recommended to store them as they have been contained in the inner container at the time of delivery from us.)

KAOHSIUNG HITACHI ELECTRONICS CO.,LTD.	DATE	Jun.04,'04	Sh. No.	7B64PS 2711-SP14Q003-3	PAGE	11-2/3
---	------	------------	------------	------------------------	------	--------

11.7 SAFETY

- (1) It is recommendable to crash damaged or unnecessary LCDs into pieces and wash off liquid crystal by either of solvents such as acetone and ethanol , which should be burned up later.
- (2) When any liquid leaked out of a damaged glass cell comes in contact with your hands , please wash it off well with soap and water.

KAOHSIUNG HITACHI ELECTRONICS CO.,LTD.	DATE	Jun.04,'04	Sh. No.	7B64PS 2711-SP14Q003-3	PAGE	11-3/3
---	------	------------	------------	------------------------	------	--------

12. DESIGNATION OF LOT MARK

LOT MARK

Lot mark is consisted of 4 digital number.

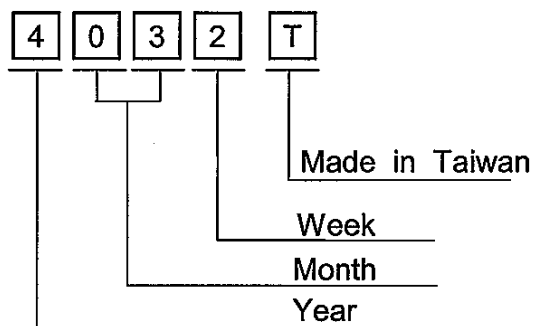

YEAR	FIGURE IN LOT MARK
2004	4
2005	5
2006	6
2007	7
2008	8

Note 1 : Some products have alphabet at the end or the first.

MONTH	FIGURE IN LOT MARK	MONTH	FIGURE IN LOT MARK
Jan.	01	Jul.	07
Feb.	02	Aug.	08
Mar.	03	Sep.	09
Apr.	04	Oct.	10
May	05	Nov.	11
Jun.	06	Dec.	12

WEEK (DAY IN CALENDAR)	FIGURE IN LOT MARK
01~07	1
08~14	2
15~21	3
22~28	4
29~31	5

Location of lot mark : On the back side of LCM

4 0 3 2 T

13. PRECAUTION FOR USE

13.1 A limit sample should be provided by the both parties on an occasion when the both parties agreed its necessity. Judgment by a limit sample shall take effect after the limit sample has been established and confirmed by the both parties.

13.2 On the following occasions, the handling of the problem should be decided through discussion and agreement between responsible persons of the both parties.

- 1) When a question is arisen in the specifications.
- 2) When a new problem is arisen which is not specified in this specifications.
- 3) When an inspection specifications change or operating condition change in customer is reported to HITACHI, and some problem is arisen in this specification due to the change.
- 4) When a new problem is arisen at the customer's operating set for sample evaluation in the customer site.

The precaution that should be observed when handling LCM have been explained above. If any points are unclear or if you have any request , please contact HITACHI.

KAOHSIUNG HITACHI ELECTRONICS CO.,LTD.	DATE	Jun.04,'04	Sh. No.	7B64PS 2713-SP14Q003-3	PAGE	13-1/1
---	------	------------	------------	------------------------	------	--------