

HR2S



Safety Relay Modules

**Compact Design and Maintenance Improvements
for Outstanding Usability!**



HR2S-301P

HR2S-301N

HR2S-332N-
T075/T15/T30

With time-delay output

Compliant with
Performance level (PL) **e**
Category 4
EN ISO 13849-1

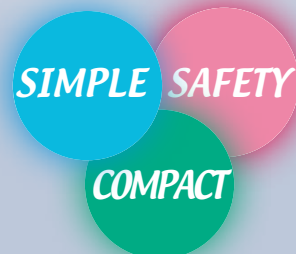

IDEC CORPORATION

HR2S

Safety Relay Modules

Slim safety relay module with spring terminals enables easy wiring!



HR2S-301P

SIMPLE

Simple wiring procedure

No complex work required. Just insert a ferrule into the terminal. The wire is locked into the spring terminal so a screwdriver is not required when inserting the wire.

Insert



1 No tools needed. Directly insert a ferrule into the terminal. The wire is locked.

Removal



1 Insert a flat screwdriver into the terminal entrance.



2 Remove the wire by releasing the lock with a screwdriver.

Removable terminal block enables easy replacement

The terminals can be attached and removed easily with a flat screwdriver allowing easy replacement of the module.



The terminal cover detects improper connection

The terminal cover does not close if the terminal is not fully inserted into the module.



Not fully inserted

Operation modes can be changed with a single action

The switch on the front panel allows switching between Auto and Manual modes.



SAFETY

Complies with international standards

- Safety Category 4, Performance Level e according to EN ISO 13849-1: 2008
- TÜV SÜD European and North American (NRTL)



COMPACT

Compact design enables installation in a narrow space

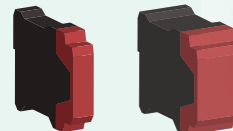

HR2S-301P
HR2S-301N

22.5mm

HR2S-332NT

45mm



HR2S-301P



- Compliant with categories 2 and 3 when used with a safety switch.
- Compliant with categories 2 (type 2) and 4 (type 4) when used with a safety light curtain.

3NO and 1NC output contacts

Auxiliary output (NC) can be used for monitoring.

HR2S-301N



Compliant with Category 4

3NO and 1NC output contacts

Auxiliary output (NC) can be used for monitoring.

HR2S-332NT-075/15/30

Time-delay output



3NO (safety output) and 3NO (time-delay safety output)

Time-delay output compliant with category 4

Time setting can be selected from 31 different time ranges

- HR2S-332N-T075=0.5/1/1.5/2/2.5/3/3.5/4/4.5/5/5.5/6/6.5/7/7.5s
- HR2S-332N-T15=1/2/3/4/5/6/7/8/9/10/11/12/13/14/15s
- HR2S-332N-T30=2/4/6/8/10/12/14/16/18/20/22/24/26/28/30s

(110127)

HR2S-301P/HR2S-301N Safety Relay Modules

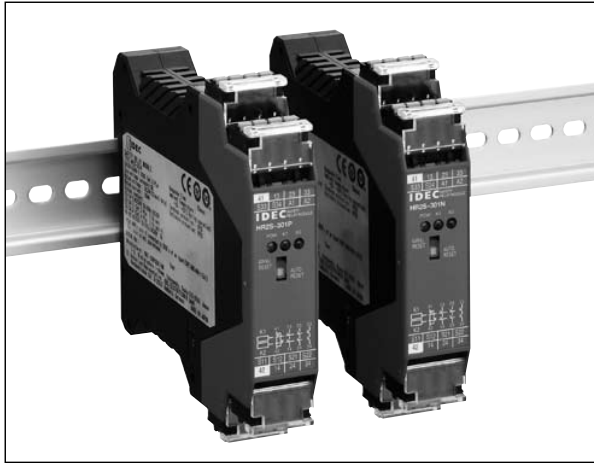

Dimensions

All dimensions in mm

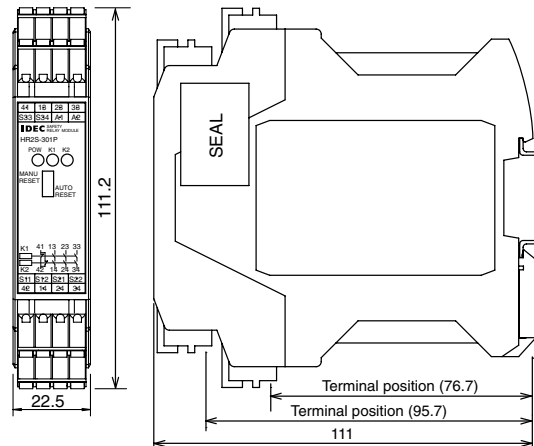

HR2S-301P/HR2S301N

Package Quantity: 1

Contact Configuration		Input	Supply Voltage	Part No.
Safety Output	Auxiliary Contact			
3NO	1NC	Positive	24V DC -15% to +10%	HR2S-301P
		Negative	24V DC -15% to +10%	HR2S-301N

Specifications

Applicable Standards	EN ISO 13849-1: 2008 EN 954-1: 1996 EN 50178: 1997 EN 55011/A2: 2007 EN 61000-6-2: 2005 IEC/EN 61496-1: 2006 UL508/R2005-07 (Note 1) CAN/CSA C22.2 No.14: 2005 (Note 1)
Applicable Standards for Use	EN 60204-1: 2006
Performance level (PL)	e (EN ISO 13849-1)
Safety Category (Note 2)	3 or 4 (EN ISO 13849-1)
Stop Category	0 (IEC/EN 60204-1)
Operating Temperature	-10 to +55°C (no freezing)
Relative Humidity	30 to 85% (no condensation)
Altitude	0 to 2000m (operating)
Insulation Resistance	100Ω minimum (500V DC megger, same measurement positions as dielectric strength)
Dielectric Strength	Between outside housing and internal circuit: 3,750V AC, 1 minute Between outputs of different poles: 2,500V AC, 1 minute Between input and output terminals: 2,500V AC, 1 minute Between power supply and output terminals: 2,500V AC, 1 minute
Shock Resistance	300 m/s ² , pulse width 11m sec, 3 shocks in each of 3 axes
Bump	100 m/s ² , pulse width 16m sec, 1000 times in each of 3 axes
Vibration Resistance	10 to 55 Hz, 1 octave/minute, 0.7 mmp-p in each of 3 axes, 20 sweeps, 5 to 55 Hz, 30 m/s ² , for 2 hours in each of 3 axes
Degree of Protection	Terminals: IP20 Housing: IP40
Rated Voltage	24V DC -15% +10%
Power Consumption	2.2W (26.4V DC)
Overcurrent Protection	Built-in, electronic (approx. 0.9A)
Contact Resistance	200 mΩ maximum (Note 3)
Turn-On Time	50 ms maximum (Note 4)
Minimum Applicable Load	24V DC / 5 mA (Reference value)
Response Time	20 ms maximum (Note 4) (Note 5)
Overvoltage Category	III (IEC60664-1)
Pollution Degree	2 (IEC60664-1)

Rated Insulation Voltage (output contact)		250V (IEC60664-1)	
Output Contact Ratings	Terminals 13-14 23-24 33-34	Rated Load (Note 6) (Note 7)	250V AC / 30V DC (resistive load) (Note 8) Category 3 or lower: 5.0A maximum Category 4 or lower: 3.6A maximum
		Safety AC15	240V AC / 2A cosφ=0.3
	Circuit DC13	24V DC / 1A L/R=48 ms	
	No. of Outputs	3 (NO contact output)	
Output Contact Ratings	Terminals 41-42	Rated Load (Note 7)	250V AC / 30V DC (resistive load) Category 3 or lower: 5.0A maximum Category 4 or lower: 3.6A maximum
		Safety AC15	240V AC / 2A cosφ=0.3
	Circuit DC13	24V DC / 1A L/R=48 ms	
	No. of Outputs	1 (NC contact output)	
Mechanical Durability	5,000,000 operations minimum		
Electrical Durability	100,000 operations minimum		
Wire Size	0.2 mm ² to 1.5 mm ² (24 to 16 AWG)		
Weight (approx.)	200g		

Note 1: UL and CSA are approved by TÜV SÜD America Inc., an accredited NRTL.

Note 2: HR2S-301N is recommended for use in category 4 safety applications. The requirements of the safety category must be determined according to the safety equipment. We recommend that you consult a third party organization. Categories may change depending on the combination of the safety equipment. Categories may also change depending on the output contact ratings.

Note 3: Measured using 5 or 6V DC, 1A voltage drop method.

Note 4: When measured at the rated voltage (at 20°C), excluding contact bounce time.

Note 5: The time from when the safety input turns OFF to when the safety output turns OFF.

Note 6: Leave 5 mm of space between the sides of the module when more than 3A is continuously applied to the relay contact.

Note 7: The module is not suitable for use with a load less than the minimum applicable load. Once a large load is applied, contacts may not operate with a small load.

Note 8: The maximum current of the safety output contact is specified by the approved standard.

Category 4 HR2S-301N, HR2S-301P + Type 4 OSSD's 3.6A
Category 3 HR2S-301P 5.0A

• To prevent the safety output contact from overcurrent, use a fuse. To satisfy Category 4, use a fuse with a maximum current of 3.6A. This fuse is not required if the short circuit current is less than 5A.

HR2S-301P/HR2S-301N Safety Relay Modules

Terminal Arrangement

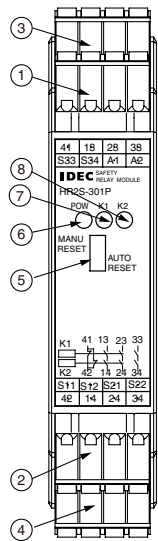

Part Description

Part No.	Part Names and Functions
1	CN1: Power supply input, start/off-check input
2	CN2: Safety input (dual channel)
3	CN3: Safety output contact
4	CN4: Safety output contact
5	Switch: Select AUTO or MANU mode
6	POW: Power LED
7	K1: ON-LED for safety output
8	K2: ON-LED for safety output

Terminal Arrangement

Terminal	Markings	I/O Signals	Notes
CN1	A1	Power supply +24V DC input	Use a dry contact.
	A2	Power supply 0V input	
	S33	Start/off-check input	
	S34		
CN2	S11	Safety input 1	Common
	S12		Function
	S21	Safety input 2	Common
	S22		Function
CN3 CN4	41-42	Monitor contact for safety output (NC)	Rated load 250V AC / 30V DC, 1A (Resistive load)
	13-14 23-24 33-34	Safety output contact (NO)	Rated load 250V AC / 30V DC (Note) (Resistive load)

Note: 5.0A max. Category 3 or lower HR2S-301P
3.6A max. Category 4 HR2S-301N, HR2S-301P + Type 4 OSSD's

HR2S-301P Wiring Diagram

Safety Category 4 Circuit Example (using a safety light curtain)

*EDM function disabled

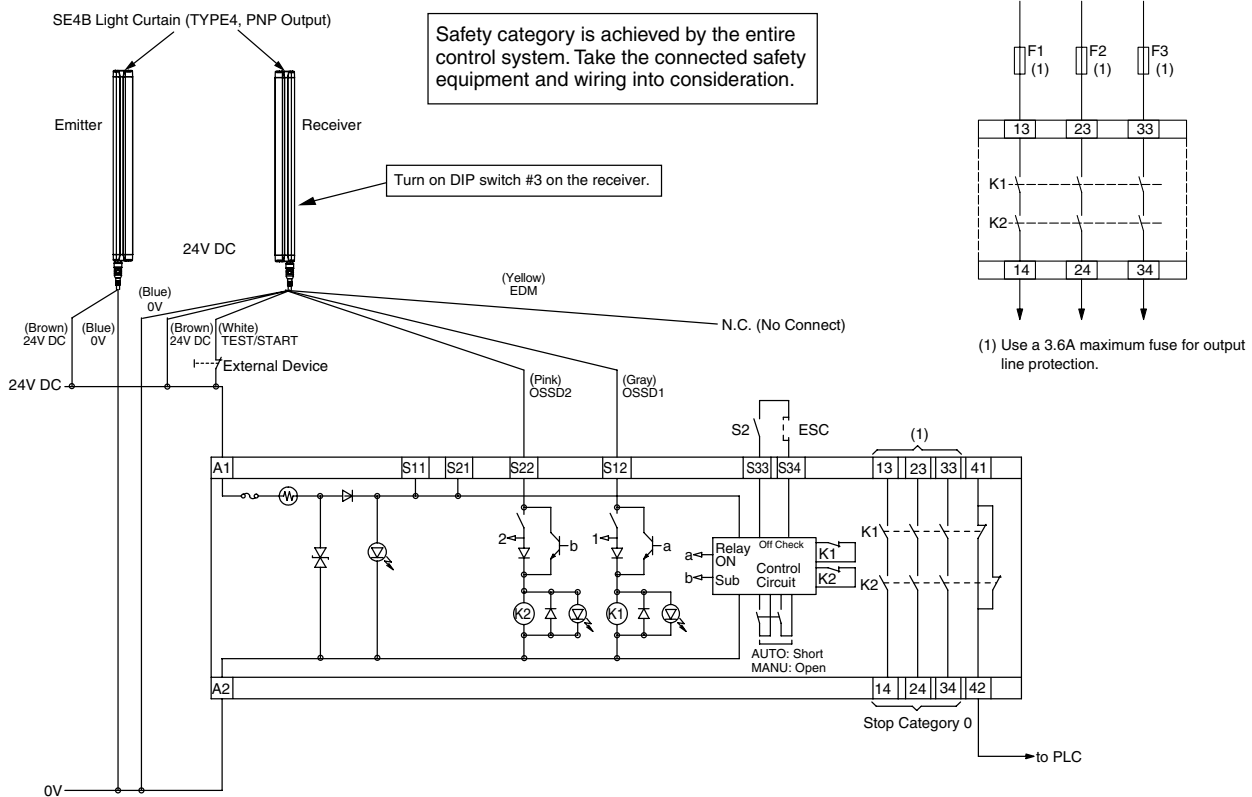

The SE4B light curtains are used in the above system.

- ESC: External Start Condition
- F1 to 3: Protective fuse for the output of safety relay module
- K1 to 2: Safety Contactor
- S2: Start Switch
- S33-S34: Feedback loop

HR2S-301P/HR2S-301N Safety Relay Modules

HR2S-301P Operation Chart

Using OSSD outputs of a light curtain (EPSE)

AUTO mode

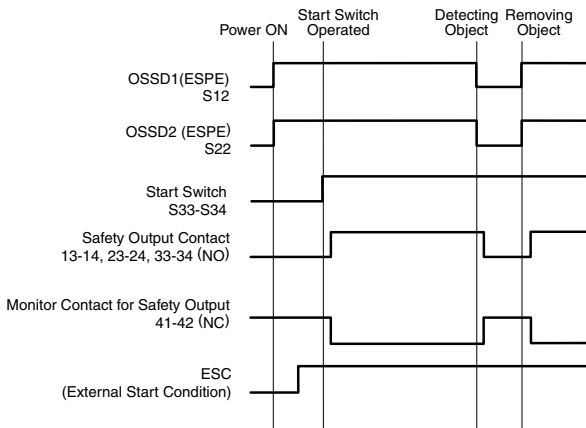

MANU mode

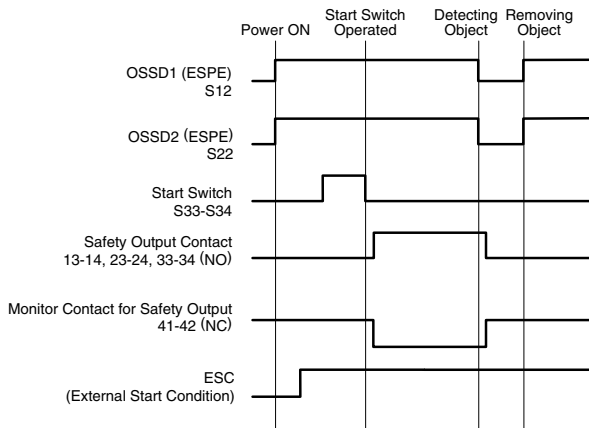

HR2S-301N Wiring Diagram

Safety Category 4 (3) Circuit Example (using an emergency stop switch)

Safety category is achieved by the entire control system. Take the connected safety equipment and wiring into consideration.

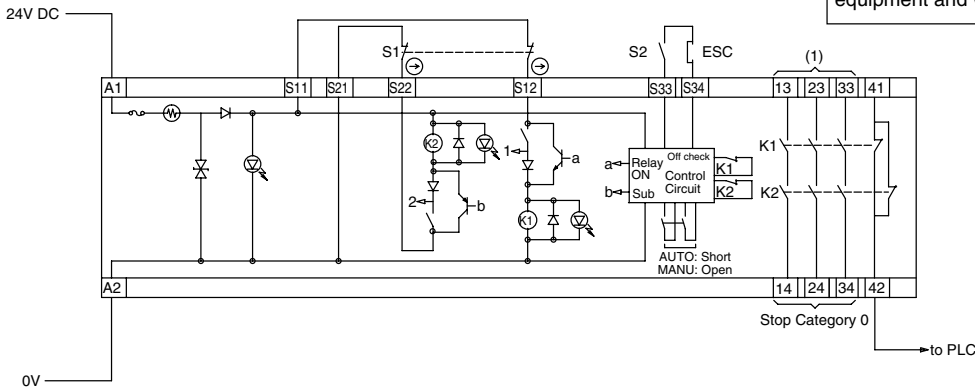

- ESC: External start condition
- F1 to 3: Protective fuse for the output of safety relay module
- S1: Emergency stop switch with 2NC contacts, safety switch (recommended)
- S2: Start Switch
- S33-S34: Feedback loop

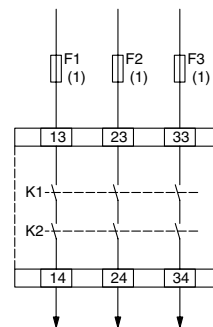

(1) Use a 3.6A maximum fuse for output line protection.

HR2S-301P/HR2S-301N Safety Relay Modules

Safety Category 3 Circuit Example (using multiple emergency stop switches and a safety switch)

Safety category is achieved by the entire control system. Take the connected safety equipment and wiring into consideration.

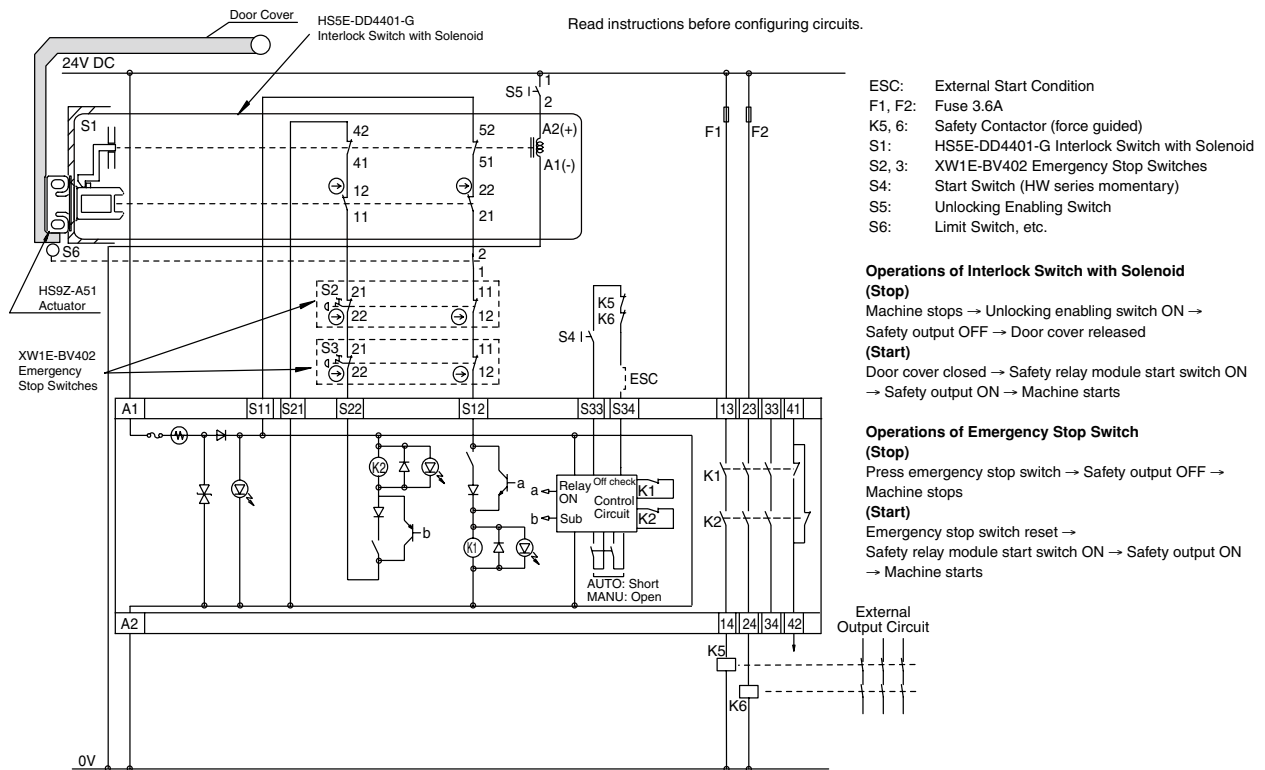

HR2S-301N Operation Chart

Using an emergency stop switch

AUTO mode

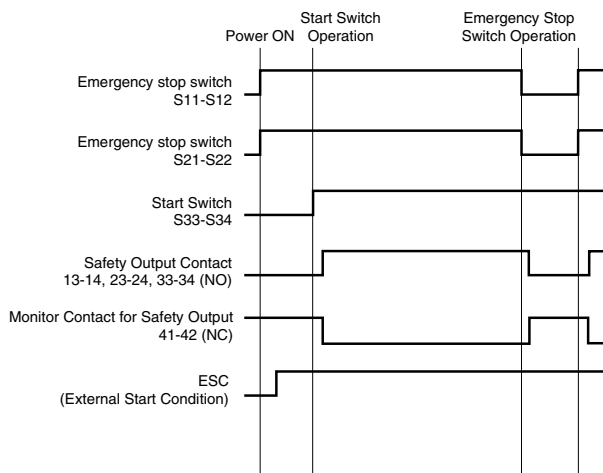

MANU mode

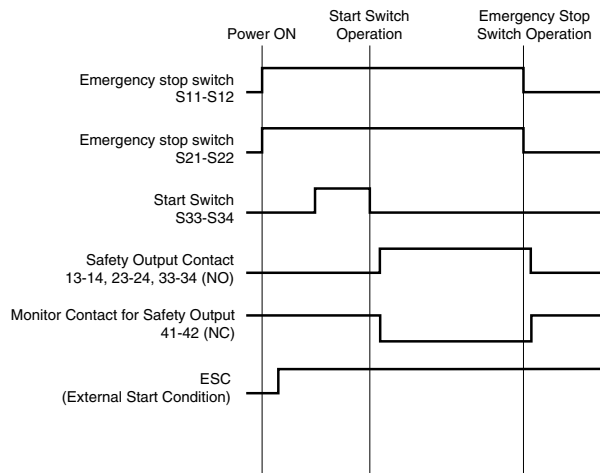

HR2S-332N-T075/T15/T30 Safety Relay Modules

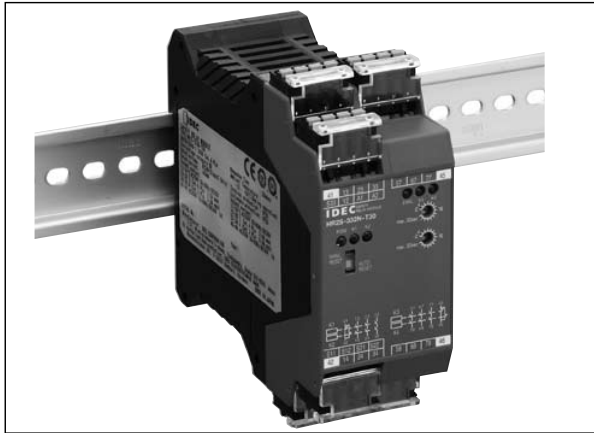

HR2S-332N-T075/T15/T30

Package Quantity: 1

Contact Configuration			Input	Supply Voltage	Part No.
Safety Output	Time-delay Safety Output	Auxiliary Contact			
3NO	3NO	2NC	Negative	24V DC -15% to +10%	HR2S-332N-T075 HR2S-332N-T15 HR2S-332N-T30

Note: Time-delay duration can be set in 15 steps. 7.5 sec. (0.5, 1.0 ... 7.0, 7.5); 15 sec. (1, 2 ... 14, 15); 30 sec. (2, 4 ... 28, 30)

Specifications

Applicable Standards	EN ISO 13849-1: 2008 EN 954-1: 1996 EN 50178: 1997 EN 55011/A2: 2007 EN 61000-6-2: 2005 EN 61496-1: 2004 UL508/R2005-07 (Note 1) CAN/CSA C22.2 No.14: 2005 (Note 1)
Applicable Standards for Use	EN 60204-1: 2006
Performance level (PL)	e (EN ISO13849-1)
Safety Category	4 (EN ISO13849-1)
Stop Category	0, 1 (IEC/EN 60204-1) (Note 2)
Operating Temperature	-10 to +55°C (no freezing)
Relative Humidity	30 to 85% (no condensation)
Altitude	0 to 2000m (operating)
Insulation Resistance	100 MΩ minimum (500V DC megger, same measurement positions as dielectric strength)
Dielectric Strength	Between outside housing and internal circuit: 3,750V AC, 1 minute Between outputs of different poles: 2,500V AC, 1 minute Between input and output terminals: 2,500V AC, 1 minute Between power supply and output terminals: 2,500V AC, 1 minute
Shock Resistance	300 m/s ² , pulse width 11m sec, 3 times in each of 3 axes
Bump	100 m/s ² , pulse width 16m sec, 1000 times in each of 3 axes
Vibration Resistance	10 to 55 Hz, 1 octave/minute, 0.7 mmp-p in each of 3 axes, 20 sweeps, 5 to 55 Hz, 30 m/s ² , for 2 hours in each of 3 axes
Degree of Protection	Terminals: IP20 Housing: IP40
Rated Voltage	24V DC -15% to +10%
Power Consumption	4.6W (26.4V DC)
Overcurrent Protection	Built-in, electronic (approx. 0.9A)
Contact Resistance	200 mΩ maximum (measured using 5 or 6V DC, 1A voltage drop method)
Turn-On Time	50 ms maximum
Minimum Applicable Load	24V DC / 5 mA (reference value)
Response Time	20 ms maximum (Note 3) (Note 4)
Overvoltage Category	III (IEC60664-1)
Pollution Degree	2 (IEC60664-1)
Rated Insulation Voltage (output contact)	250V (IEC60664-1)

Dimensions

All dimensions in mm

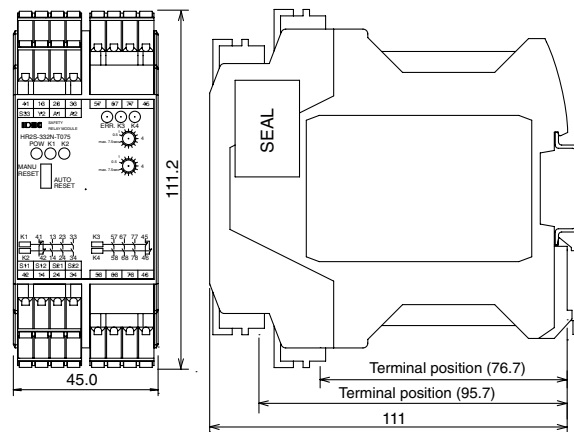

Output Contact Ratings	Terminals	Rated Load (Note 5) (Note 6)		250V AC / 30V DC (resistive load) (Note 7) Category 3 or lower: 5.0A maximum Category 4 or lower: 3.6A maximum
		Safety	AC15	
Terminals 13-14 23-24 33-34	Circuit	AC15	240V AC / 2A cosφ=0.3	240V AC / 2A cosφ=0.3 24V DC / 1A L/R=48 ms
		DC13	24V DC / 1A L/R=48 ms	
		No. of Outputs	3 (NO contact output)	
Terminals 41-42	Circuit	AC15	240V AC / 2A cosφ=0.3	250V AC / 30V DC (resistive load) Category 3 or lower: 5.0A maximum Category 4 or lower: 3.6A maximum
		DC13	24V DC / 1A L/R=48 ms	
		No. of Outputs	1 (NC contact output)	
Terminals 57-58 67-68 77-78	Circuit	AC15	240V AC / 2A cosφ=0.3	250V AC / 30V DC (resistive load) (Note 7) Category 3 or lower: 5.0A maximum Category 4 or lower: 3.6A maximum
		DC13	24V DC / 1A L/R=48 ms	
		No. of Outputs	3 (NO contact output)	
Terminals 45-46	Circuit	AC15	240V AC / 2A cosφ=0.3	250V AC / 30V DC (resistive load) Category 3 or lower: 5.0A maximum Category 4 or lower: 3.6A maximum
		DC13	24V DC / 1A L/R=48 ms	
		No. of Outputs	1 (NC contact output)	
Mechanical Durability		5,000,000 operations minimum		
Electrical Durability		100,000 operations minimum		
Wire Size		0.2 mm ² to 1.5 mm ² (24 to 16 AWG)		
Weight (approx.)		320g		

Note 1: UL and CSA are approved by TÜV SÜD America Inc., an accredited NRTL.

Note 2: Safety output contact: Stop Category 0

Time-delay output contact: Stop Category 1

Note 3: When measured at the rated voltage (at 20°C), excluding contact bounce time.

Note 4: The time from when the safety input turns OFF to when the safety output turns OFF.

Note 5: Leave 5 mm of space between the sides of the module when more than 3A is continuously applied to the relay contact.

Note 6: The module is not suitable for use with a load less than the minimum applicable load. Once a large load is applied, contacts may not operate with a small load.

Note 7: The maximum current of the safety output contact is specified by the approved standard.

Category 4: 3.6A Category 3: 5.0A

To prevent the safety output contact from overcurrent, use a fuse. To satisfy Category 4, use a fuse with a maximum current of 3.6A. This fuse is not required if the short circuit current is less than 5A.

HR2S-332N-T075/T15/T30 Safety Relay Modules

Terminal Arrangement

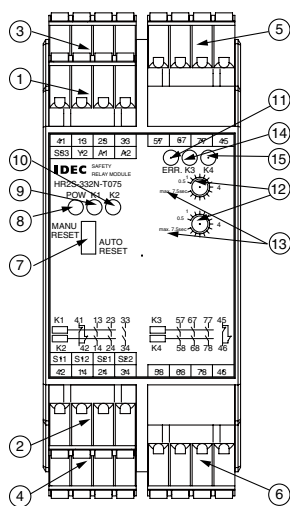

Part Description

Part No.	Part Names and Functions
1	CN1: Power supply input, start/off-check input
2	CN2: Safety input (dual channel)
3	CN3: Safety output contact
4	CN4: Safety output contact
5	CN5: Time-delay safety output contact
6	CN6: Time-delay safety output contact
7	Switch: Select AUTO or MANU mode
8	POW: Power LED
9	K1: ON-LED for safety output
10	K2: ON-LED for safety output
11	ERR: Error (timer) LED
12	Switches: Time-delay. The same value should be set for both switches. Otherwise, an error occurs. Characters: Maximum time-delay duration is displayed. 0.75: 7.5 sec., 15: 15 sec., 30: 30 sec.
14	K3: ON-LED for safety output
15	K4: ON-LED for safety output

Terminal Arrangement

Terminals	Markings	I/O Signals	Remarks	
CN1	A1	Power supply +24V DC input	Use a dry contact.	
	A2	Power supply 0V input		
	S33	Start/off-check input		
CN2	S11	Safety input 1	Common	Use a dry contact.
	S12		Function	
	S21	Safety input 2	Common	
	S22		Function	
CN3 CN4	41-42	Monitor contact for safety output (NC)	Rated load 250V AC / 30V DC 1A (Resistive load)	
	13-14	Safety output contact (NO)	Rated load 250V AC / 30V DC (Note) (Resistive load)	
	23-24			
CN5 CN6	33-34	Time-delay safety output contact (NC)	Rated load 250V AC / 30V DC 1A (Resistive load)	
	45-46			
	57-58			Time-delay safety output contact (NO)
	67-68			
77-78	Rated load 250V AC / 30V DC (Note) (Resistive load)			

Note: 5.0A maximum Category 3 or lower
3.6A maximum Category 4

HR2S-332N-T075/T15/T30 Wiring Diagram

Safety Category 4 Circuit Example (using an emergency stop switch)

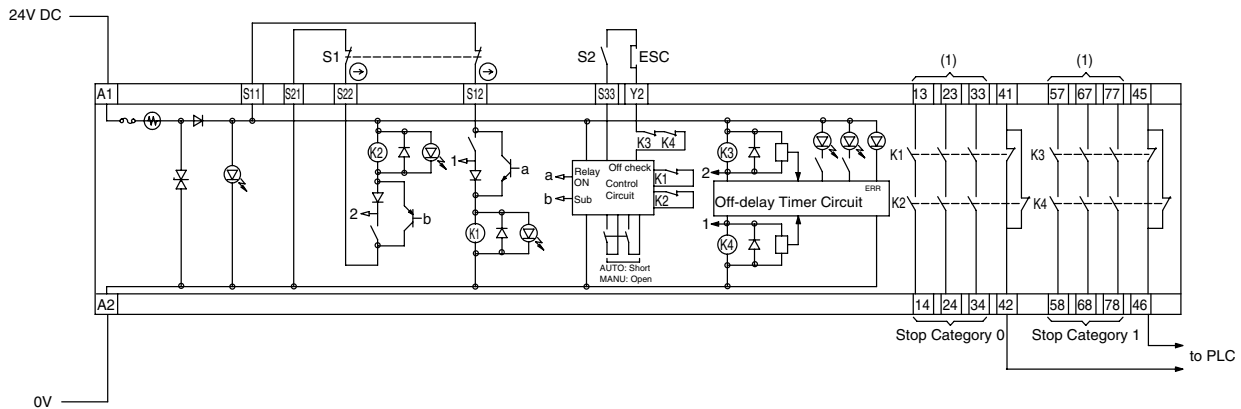

- ESC: External Start Condition
- F1 to 6: Protective fuse for the output of safety relay module
- S1: Emergency stop switch with 2NC contacts, safety switch (recommended)
- S2: Start Switch
- S33-Y2: Feedback loop

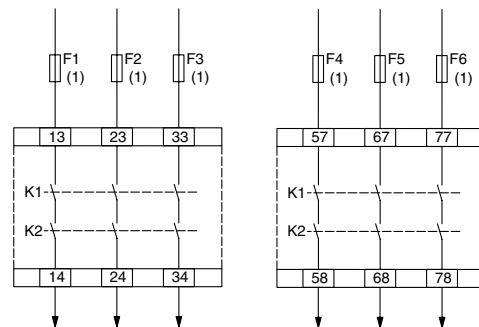

(1) Use a 3.6A maximum fuse for output line protection.

HR2S-332N-T075/T15/T30 Safety Relay Modules

Safety Category 3 Circuit (using multiple emergency stop switches)

Safety category is achieved by the entire control system. Take the connected safety equipment and wiring into consideration.

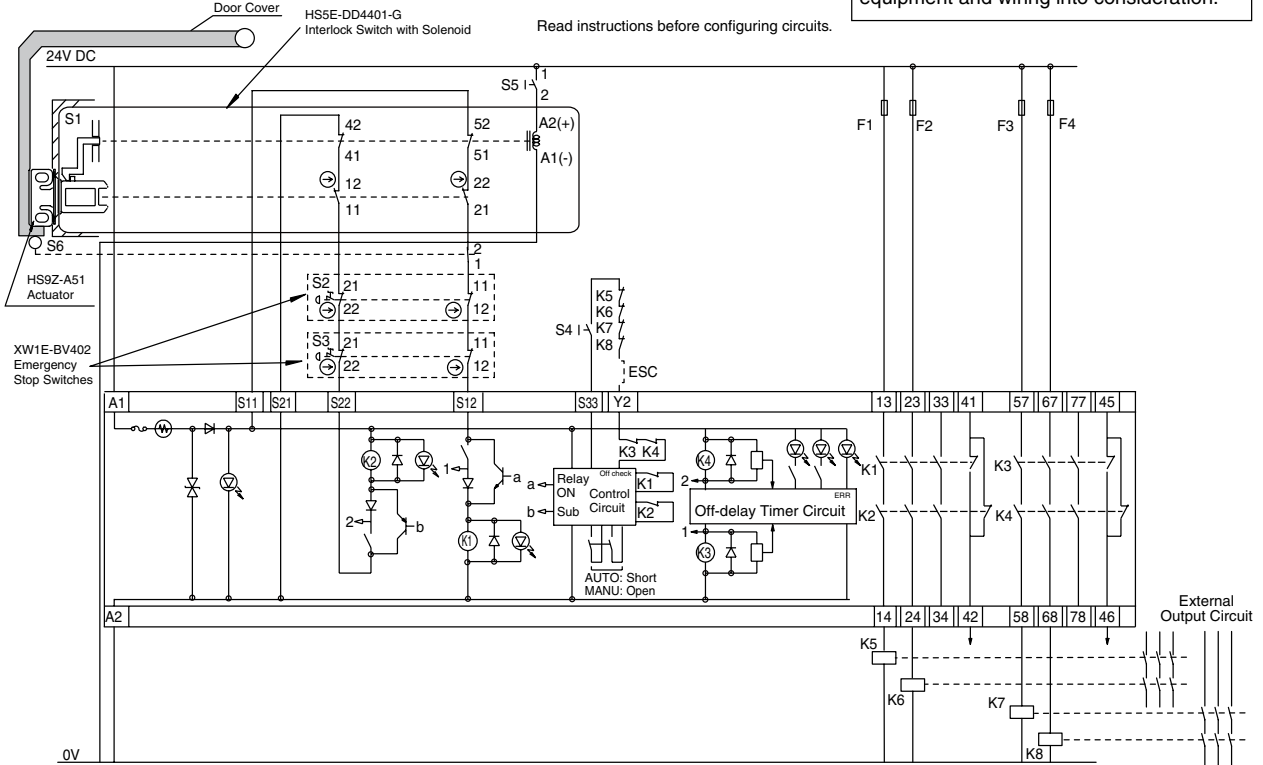

- ESC: External Start Condition
- F1 to F4: Fuse 3.6A
- K5 to 8: Safety Contactor
- S1: HS5E-DD4401-G Interlock Switch with Solenoid
- S2,3: XW1E-BV402 Emergency Stop Switches
- S4: Start Switch (HW series momentary)
- S5: Unlocking Enabling Switch
- S6: Limit Switch, etc.

- Operations of Interlock Switch with Solenoid**
- (Stop)**
Machine stops → Unlocking enabling switch ON → Safety output OFF → Door cover released
- (Start)**
Door cover closed → Safety relay module start switch ON → Safety output ON → Machine starts
- Operations of Emergency Stop Switch**
- (Stop)**
Press emergency stop switch → Safety output OFF → Machine stops
- (Start)**
Emergency stop switch reset → Safety relay module start switch ON → Safety output ON → Machine starts

HR2S-332N-T075/T15/T30 Operation Chart

Using emergency stop switches

AUTO mode

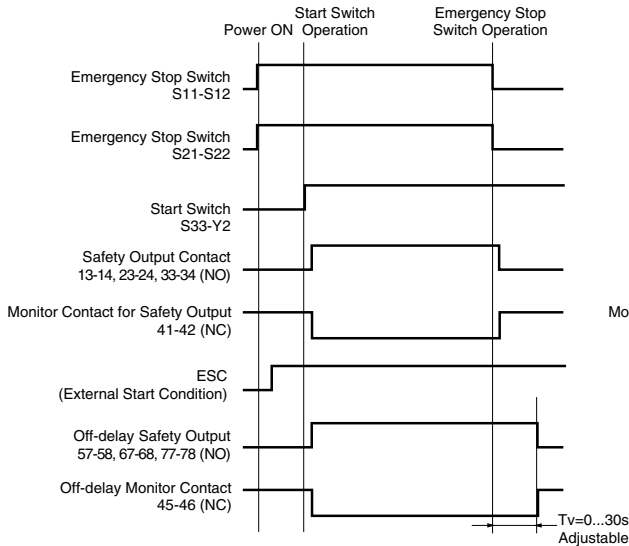

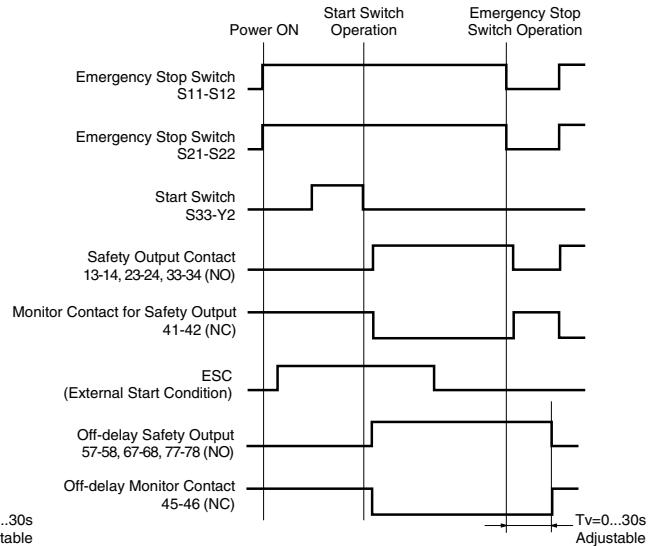

MANU mode

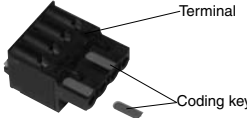

HR2S Safety Relay Modules

Maintenance Parts

Name	Part No.	Ordering No.	Package Quantity	Remarks
Terminal / Coding Key 	HR9Z-PMT1	HR9Z-PMT1PN04	1 set (4 terminals and 18 coding keys)	Coding keys are used to prevent incorrect insertion of terminals.
Terminal Cover 	HR9Z-PMC1	HR9Z-PMC1PN10	10	Used to make sure that the terminals are fully inserted.
Protective Tape 	HR9Z-PE1	HR9Z-PE1PN05	5	Used to protect the AUTO/MANU switch on the front of the module.

Residual Risk (EN ISO/ISO12100-1)

The wiring diagrams in this catalog have been tested under actual operating conditions. The HR2S safety relay module can be used in a safety circuit by connecting to the safety equipment compliant to applicable standards. Consider residual risk in the following circumstances.

a) When circuits other than described in this catalog are used.

b) When the applicable standards of machine operation are not observed, or when the machine is not adjusted or maintained properly (observe a maintenance schedule).
 c) When the contacts of relays and contactors for connecting with safety outputs are not forced guided compliant with EN 50205.



Safety Precautions

- For safe operation, be sure to turn the power off before wiring or installation.
- Use within the specified voltage. Do not use power supplies that produce high ripple voltage or abnormal voltage.
- Do not use the module with an electrical load that exceeds the switching capacity.
- Do not use the module in places where inflammable or explosive gases exist. Otherwise, fire or explosion may occur due to a voltage arc caused by switching of contacts.
- The module is designed for use in typical machinery manufacturing facilities. The module shall not be used for nuclear controls, train, aeronautics, automobiles, engines, medical, or entertainment devices or facilities.
- Leave spaces of at least 5 mm from the sides of the module when electricity of 3A or more is continuously applied to the relay contact.
- The category of the control system (hereinafter called category) is determined based on the entire control system. Determination of the category and performance level for the control system (design of the safety-related parts of the control system) must be performed by safety experts.
- This module is classified as overvoltage category III. Make sure to take appropriate measures when designing the control system.
- Life of the module depends on conditions such as switching and electrical loads. Before operation, be sure to test under actual conditions and within the switching capacity.
- Use this module in a completely sealed control panel. Also, leave spaces of at least more than 50 mm from the top and the bottom of the module.
- Performance may be decreased when used in an environment where dust, cutting oil, or an organic solvent, are present. Contact IDEC for details.
- A resettable fuse, which does not require replacement is installed in the control circuit to prevent over current. If the switch is activated, turn off the module. When the problem is resolved, turn on the power again.

Instructions

Connecting Control Devices

Emergency stop switches

Use emergency stop switches with direct opening action compliant with EN /IEC 60947-5-1 or EN /IEC 60947-5-5.

Interlock switches

Use interlock switches with direct opening action mechanism compliant with EN /IEC 60947-5-1.

Safety light curtains and beam sensor switches

Use reliable devices compliant with the required category.

Limitation on safety light curtains:

Short-circuit diagnosis function between OSSDs for safety light curtains is not provided with this module.

Therefore, category 4 is satisfied by connecting TYPE 4 safety light curtains defined in EN / IEC 61496-1. (TYPE 4 safety light curtain: short-circuit diagnosis function between OSSDs installed)

OSSD: ESPE connected to the control system of machines that turns off when the detection device operates during normal machine operation.

Electromagnetic switches

Use reliable electromagnetic switches with force guided contact.

If a NC contact of electromagnetic switches, without it being a force guided contact, is connected to the start/off-check input, failure of the electromagnetic switch contacts cannot be detected.

Protection of contact output

For an inductive load, it is recommended to provide a surge absorber to the output contacts to prevent the contacts from welding.

When an overvoltage larger than the value rated for output contact is expected, protect the output contact with a fuse.

Other control devices

- When connecting other control devices make sure that the device complies with the required category.
- Be sure to turn the power off before switching between AUTO/MANU.

Below are warnings for the start/off-check input.

AUTO mode:

Do not use a start switch. Otherwise, the contacts of the start switch may weld and cause unexpected operation which may lead to hazards.

MANU mode:

When using a start switch, be sure to use NO (normally open) momentary switches.

For the start/off-check input, use devices with back check functions (mirror contact). Otherwise, damage may occur due to failures arising from the start switch and other causes.

After the AUTO/MANU mode is set, affix a protective tape to the switch to prevent the setting from being changed.

Installation

Mount the module to a panel using DIN rail (35 mm wide). This module can be mounted in any direction. Install the module in a control panel with a protection degree of IP54 or better.

When mounting on DIN rails, use an end clip (IDEC BNL6 end clip, optional) to prevent the module from falling off.

Wiring

Wire size

Stranded wire: 0.2 to 1.5 mm², AWG 24 to 16

Solid wire: 0.2 to 1.5 mm², AWG 24 to 16

Connect after terminating the stranded wire with a ferrule (sleeve type).

Use wiring compliant with applicable standards.

Close the terminal cover after the wiring is complete. If the terminal cover does not close, the connector may not be fully inserted.

Before wiring, make sure that there are no problems with the wires.

Connect dry voltage contacts to inputs S11 - S12 (S21 - S22), S33, S34, and Y2.

* Except when connecting safety light curtains.

Precautions when using multiple HR2S modules

A single switch (see SW1 in the diagram below) cannot be connected to multiple inputs. Use switches with independent contacts.

(Do not connect one safety device to two HR2S safety inputs in a parallel connection.)

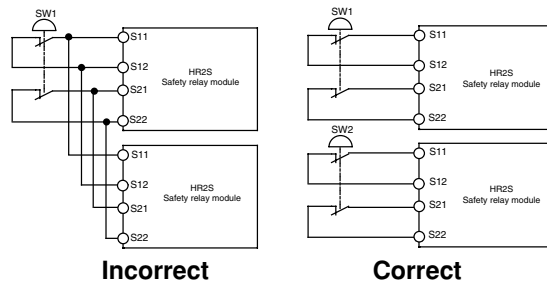

Note: Same for start/off-check input

Power supply terminal

For an external power supply, be sure to use a switching power supply compliant with the EMC Directive, IEC 60950, and NEC CLASS2. Reverse connection of the power supply may result in damage.

Ferrule (sleeve type): Use crimping metal terminals of 8 to 10 mm in length.

(Reference)

Weidmuller : H0.5/14, H0.5/16, H0.75/14, H0.75/16, H1/14, H1/16, H1.5/14, H1.5/16

PHOENIX CONTACT: AI0.5-8, AI0.5-10, AI0.75-8, AI0.75-10, AI1-8, AI1-10, AI1.5-8, AI1.5-10

Wiring length

External wiring length of a safety stop input and start/off-check input is specified as follows:

IDEC does not guarantee normal operation if a wire of a length other than specified is used.

Safety stop input: Up to 50m in total

Start/off-check input: Up to 50m in total

(Wiring resistance: 5Ω maximum)

HR1S Safety Relay Modules

Ideal for use on CE marked equipment using safety circuits with interlock switches and emergency stop switches.

- Failure diagnosis function with dual safety circuits.
- Internal relay operations can be monitored with an LED Indicator.
- Finger-safe protection.
- 35 mm-wide DIN rail mounting.
- Standard and time-delay modules available.
- Safety circuit expansion unit available.
- EN (European Norm), IEC (international standard) compliant.
- TÜV SÜD approved.



FS1A Safety Controllers

No programming is required. Configuration complete by turning on a logic switch.

- A safety circuit can be configured easily just by selecting a logic from up to 24 pre-programmed logics.
- Mode selection, partial/entire stop can be achieved just by selecting a logic.
- One SafetyOne module can connect with various safety inputs such as emergency stop switches and light curtains.
- The status of safety I/Os and the SafetyOne errors can be monitored.
- Solenoid drive output is provided, eliminating the need for a PLC.
- IEC 61508 safety integrity level 3, ISO 13849-1 performance level e, and EN954-1 control category 4 compliant.



Specifications and other descriptions in this catalog are subject to change without notice.



IDEC CORPORATION

7-31, Nishi-Miyahara 1-Chome, Yodogawa-ku, Osaka 532-8550, Japan
Tel: +81-6-6398-2571, Fax: +81-6-6392-9731
E-mail: marketing@idec.co.jp

IDEC CORPORATION (USA)
1175 Elko Drive, Sunnyvale,
CA 94089-2209, USA
Tel: +1-408-747-0550 / (800) 262-IDEC (4332)
Fax: +1-408-744-9055 / (800) 635-6246
E-mail: opencontact@idec.com

IDEC CANADA LIMITED
3155 Pepper Mill Court, Unit 4, Mississauga,
Ontario, L5L 4X7, Canada
Tel: +1-905-890-8561, Toll Free: (888) 317-4332
Fax: +1-905-890-8562
E-mail: sales@ca.idec.com

IDEC AUSTRALIA PTY. LTD.
Unit 17, 104 Ferntree Gully Road,
Oakleigh, Victoria 3166, Australia
Tel: +61-3-8523-5900, Toll Free: 1800-68-4332
Fax: +61-3-8523-5999
E-mail: sales@au.idec.com

IDEC ELECTRONICS LIMITED
Unit 2, Beechwood, Chineham Business Park,
Basingstoke, Hampshire RG24 8WA, UK
Tel: +44-1256-321000, Fax: +44-1256-327755
E-mail: sales@uk.idec.com

IDEC ELEKTROTECHNIK GmbH
Wendenstrasse 331, 20537 Hamburg, Germany
Tel: +49-40-25 30 54 - 0, Fax: +49-40-25 30 54 - 24
E-mail: service@idec.de

IDEC (SHANGHAI) CORPORATION
Room 608-609, 6F, Gangtai Plaza, No. 700,
Yan'an East Road, Shanghai 200001, PRC
Tel: +86-21-5353-1000, Fax: +86-21-5353-1263
E-mail: idec@cn.idec.com

IDEC (BEIJING) CORPORATION
Room 211B, Tower B, The Grand Pacific Building,
8A Guanghua Road, Chaoyang District,
Beijing 100026, PRC
Tel: +86-10-6581-6131, Fax: +86-10-6581-5119

IDEC (SHENZHEN) CORPORATION
Unit AB-3B2, Tian Xiang Building, Tian'an Cyber Park,
Fu Tian District, Shenzhen, Guang Dong 518040, PRC
Tel: +86-755-8356-2977, Fax: +86-755-8356-2944

IDEC IZUMI (H.K.) CO., LTD.
Units 11-15, Level 27, Tower 1,
Millennium City 1, 388 Kwun Tong Road,
Kwun Tong, Kowloon, Hong Kong
Tel: +852-2803-8989, Fax: +852-2565-0171
E-mail: info@hk.idec.com

IDEC TAIWAN CORPORATION
8F-1, No. 79, Hsin Tai Wu Road, Sec. 1,
Hsi-Chih District, New Taipei City, Taiwan
Tel: +886-2-2698-3929, Fax: +886-2-2698-3931
E-mail: service@tw.idec.com

IDEC IZUMI ASIA PTE. LTD.
No. 31, Tannery Lane #05-01,
HB Centre 2, Singapore 347788
Tel: +65-6746-1155, Fax: +65-6844-5995
E-mail: info@sg.idec.com

www.idec.com

Cat. No. EP1319-0 FEBRUARY 2011 1.2S PRINTED IN JAPAN