

Safety Control Relay HR1S-DMB/DME

- 1NO-1NC safety input type, such as magnetic coded safety switches
- Fault diagnosis function with dual safety circuits.
- Internal relay operations can be monitored with LED Indicator.
- Finger-safe protection
- 22.5 or 45mm wide, 35mm DIN rail mounting
- EN ISO 13849-1 PL_e, Safety Cat 4 compliant, and EN 62061 SIL 3
- UL listed, CSA certified, TÜV NORD approved



HR1S-DMB (P)



HR1S-DME
HR1S-DMB

Part Numbers

Part Numbers	Terminal Style	Input
HR1S-DMB1132	Integrated terminal block	2
HR1S-DMB1132P	Removable terminal block	
HR1S-DME1132	Integrated terminal block	6
HR1S-DME1132P	Removable terminal block	

Specifications

Operating Temperature	-10 to 55°C (no freezing)	
Degree of Protection	Terminal: IP20, Housing: IP40	
Rated Power Voltage	24V DC (-20 to +20%)	
Power Consumption	HR1S-DMB: 2.5W maximum (24V DC) HR1S-DME: 3.5W maximum (24V DC)	
Overcurrent Protection	Electronic	
Control Circuit Voltage	24V DC	
Performance Level (PL)	e (EN ISO 13849-1)	
Safety Category	4 (EN ISO 13849-1)	
Safety Integrity Level (SIL)	3 (EN 62061)	
Response Time	20 ms maximum	
Input Synchronization Time	500ms max	
Overvoltage Category	III	
Pollution Degree	2	
Rated Insulation Voltage	300V	
Maximum Input Resistance	100Ω (per input point)	
No. of Outputs	Safety Circuit	2NO
	Auxiliary Contact	2NO (transistor PNP)
Output Contact Ratings	Safety Circuit	AC-15 C300: U _e = 240VAC, I _e =0.75A
		DC-13 U _e = 24V DC, I _e = 1.5A
	Transistor Circuit	24V/20 mA
	Minimum Applicable Load	17V/10 mA (initial value)
Operation Frequency	1200 operations/hour maximum	
Rated Current	Output total 12A maximum	
Wire Size	0.14 to 2.5 mm ²	
Weight	HR1S-DMB: 180g HR1S-DME: 250g	

Use a 4A fuse (Type gL) for power fuse protection.
Use a 4A (Type gL) or a 6A fast blow fuse for output fuse protection.

Dimensions (mm)

HR1S-DMB

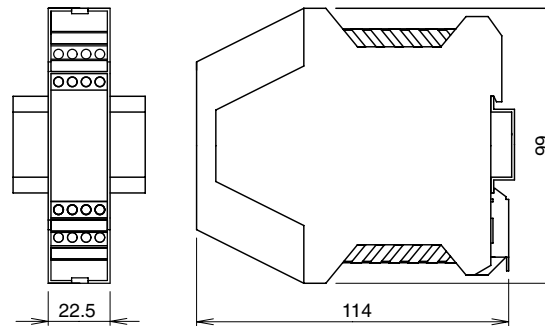

HR1S-DME

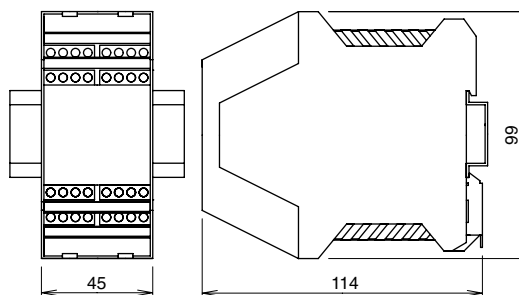

Terminal Arrangement

HR1S-DMB

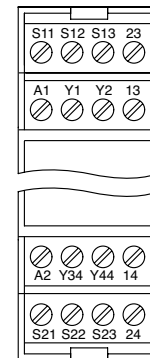

HR1S-DME

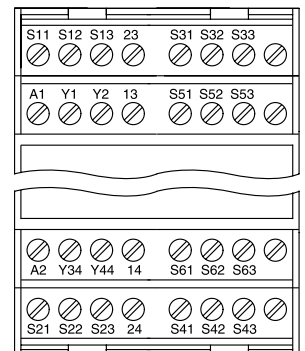

LED Indication

HR1S-DMB

- Power A1/A2:
Turns on when power circuit is normal.
Turns off when power is interrupted or the electronic fuse blows.
- Fault:
Turns on when the HR1S fails (see failure causes on page 694).
- K1/K2:
Turns on when K1/K2 relays operate.

HR1S-DME

- Power A1/A2:
Turns on when power circuit is normal.
Turns off when power is interrupted or the electronic fuse blows.
- Fault:
Turns on when the HR1S fails (see failure causes on page 694)
- K1/K2:
Turns on when K1/K2 relays operate.
- S13: NO contact of non-contact interlock switch 1
- S12: NC contact of non-contact interlock switch 1
- S23: NO contact of non-contact interlock switch 2
- S22: NC contact of non-contact interlock switch 2
- S33: NO contact of non-contact interlock switch 3
- S32: NC contact of non-contact interlock switch 3
- S43: NO contact of non-contact interlock switch 4
- S42: NC contact of non-contact interlock switch 4
- S53: NO contact of non-contact interlock switch 5
- S52: NC contact of non-contact interlock switch 5
- S63: NO contact of non-contact interlock switch 6
- S62: NC contact of non-contact interlock switch 6

Causes of Fault LED Indication

LED2: Fault	Fault Type	Fault Cause	Measures
	Internal Fault	Fault of the internal circuit	Replace the safety relay module.
	External Fault	Short circuit of the +24V power supply and input terminal	Remove the short circuit and reboot.
	External Fault	Short-circuit of the non-contact interlock switch wiring	Correct the wiring of the non-contact interlock switch and reboot.
	Synchronization time excess of switch contact input	Synchronization for the NO contact and NC contact of the non-contact interlock switch (HS7A) is 0.5 seconds or longer.	Open and close the door again.
		Fault of the non-contact interlock switch (HS7A)	Replace the non-contact interlock switch.

The HR1S-DM terminal block can be removed and installed as shown, allowing for easy installation and replacement of modules.

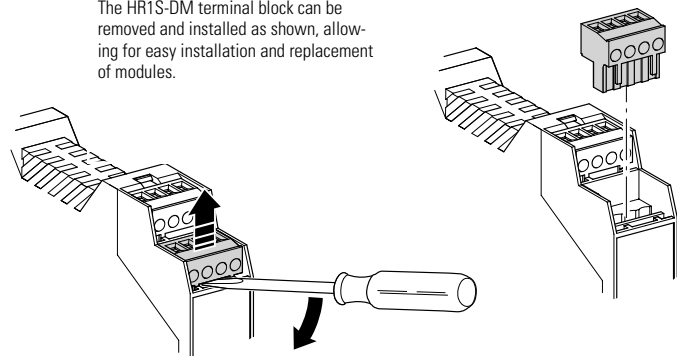

HR1S-DMB Safety Relay Module Operation Chart

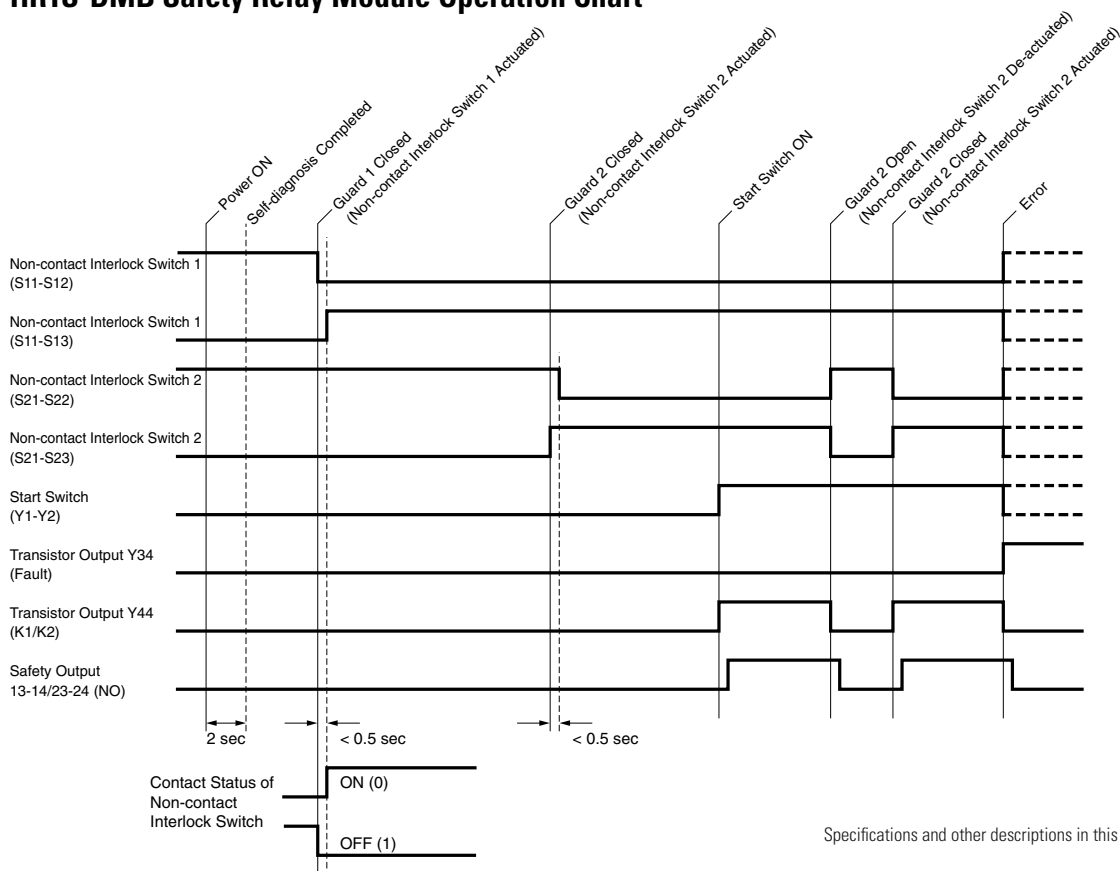

Specifications and other descriptions in this document are subject to change without notice.



IDEC Corporation • 1175 Elko Drive • Sunnyvale, CA 94089 • 800-262-IDEC (4332) • Fax: 408-745-5258 • www.IDEC.com/usa

©2011 IDEC Corporation. All Rights Reserved. 06/11 PDF only.