

DUAL UNIVERSAL ADVANCED TDMA PHY-LAYER BURST RECEIVER

FEATURES

- The BCM3138 is a universal headend advanced TDMA physical layer QPSK/QAM burst receiver
- DOCSIS/EuroDOCSIS-based, IEEE 802.14, DAVIC and DVB compliant
- Programmable demodulation including BPSK, QPSK, 8, 16, 32, 64, 128 and 256 QAM formats
- Variable symbol rates from 160 Kbaud to 5.12 Mbaud providing 320 Kbps to 40 Mbps operation
- Powerful Reed Solomon FEC decoder with byte deinterleave options for impulse/burst noise mitigation
- Burst acquisition as fast as 16 preamble symbols
- On-board 10-bit analog-to-digital converters for each channel
- Direct sampling option for DOCSIS and EuroDOCSIS via 12-bit digital input operating at 160 MHz with LVDS or TTL level interface options
- Powerful on-board equalizer provides ingress and adjacent channel overlap protection
- Integrated Fast Fourier Transform (FFT) processor with variable FFT sizes and programmable window options
- I²C or SPI-compatible microcontroller interface
- JTAG test interface
- 208-pin PQFP package
- Operates over industrial temperature range (-40 to +85 degrees C)

SUMMARY OF BENEFITS

- Presents a high-performance, integrated solution for upstream demodulation in cable over data, video and telephony applications.
- Two independent burst receivers per package enable high-density equipment designs, reducing equipment floor space requirements.
- Based on DOCSIS/EuroDOCSIS standards for use in Cable Modem Termination Systems (CMTS).
- Seamless integration with BCM3212 Advanced CMTS MAC.
- Applies to digital CATV reverse-channel receiver.
- High bps/Hz modulation enables advanced digital services over narrow RF channels.
- Includes flexible analog front end options.
- Use of on-board ADCs minimizes external components.
- Direct sampling option via external 12-bit ADC minimizes RF components.
- On-board equalizer enables operation of digital services under challenging plant conditions.
- On-chip FFT enables spectrum analysis and management of the entire upstream channel.
- Small footprint enables high-density equipment.
- Deploys advanced functions in harsh environments.
 - Distributed CMTS in Hybrid Fiber Coaxial Fiber Node

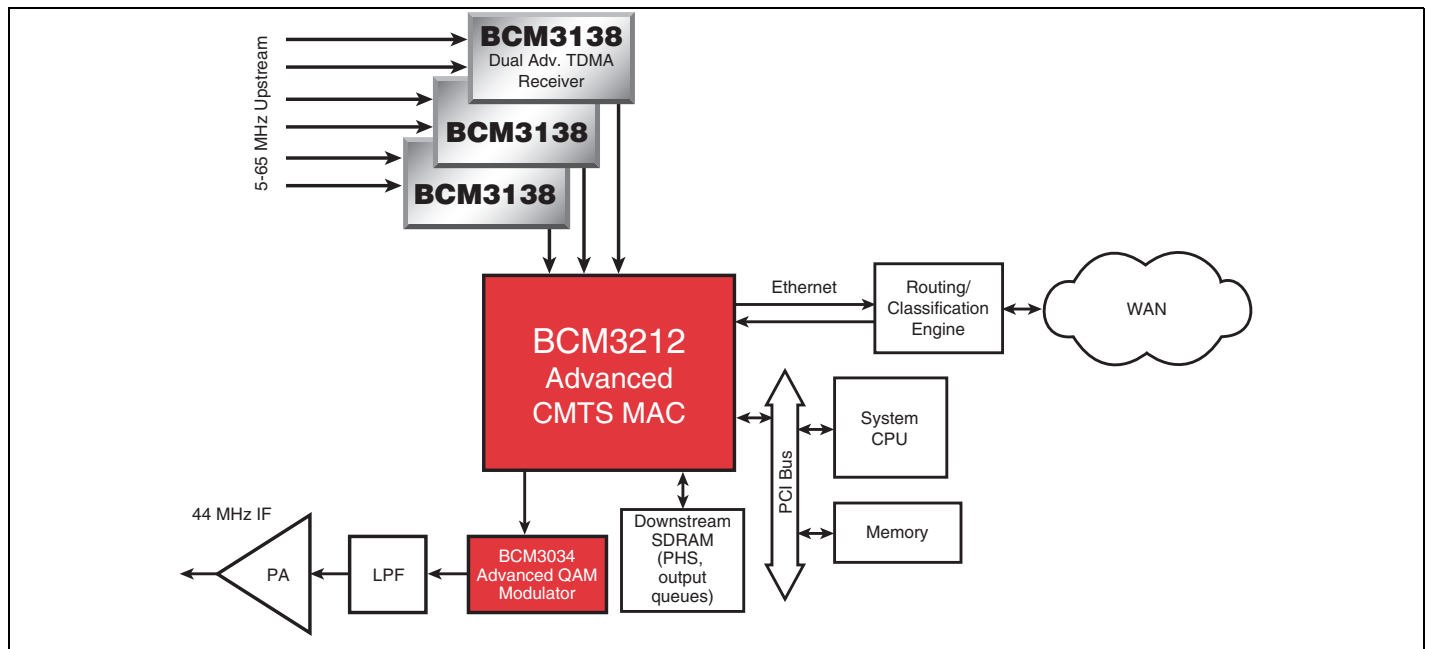

Cable Modem Termination System (CMTS) Block Diagram

OVERVIEW

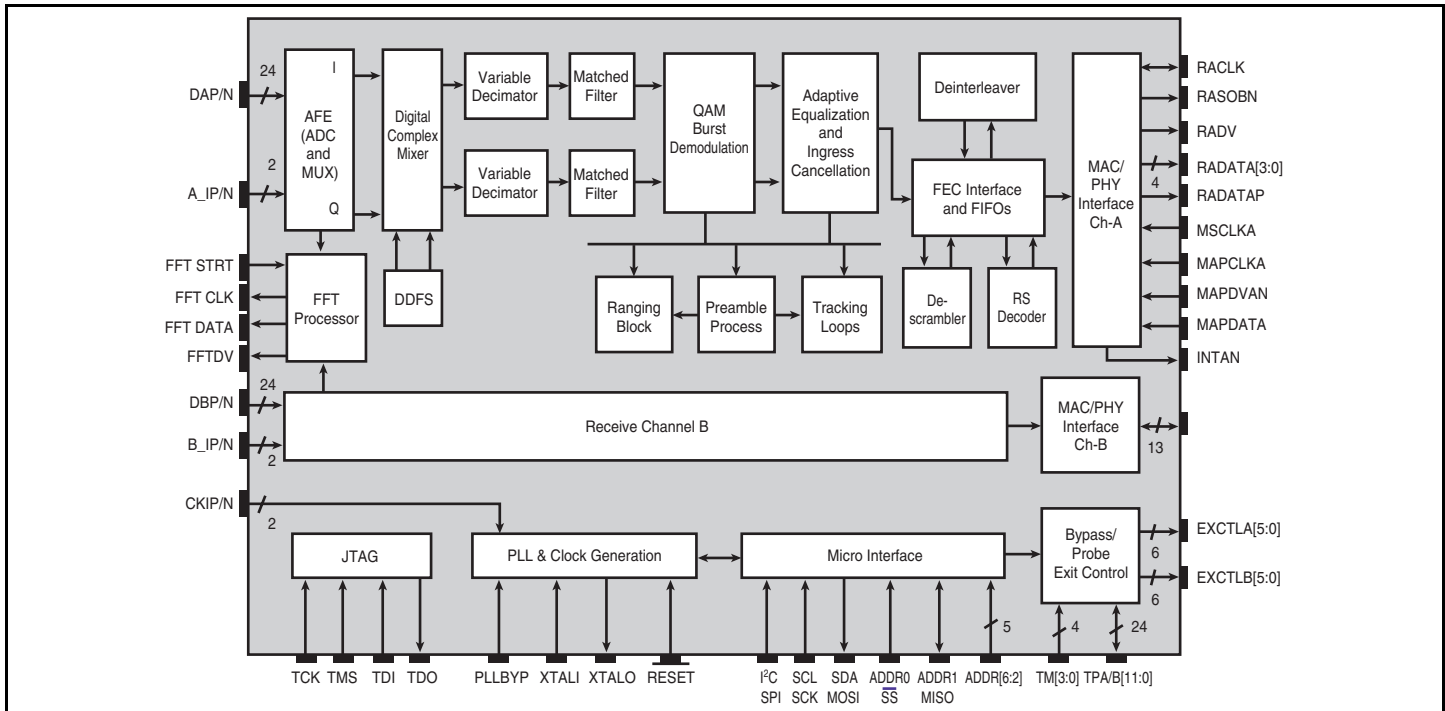

The BCM3138 QAMLink® Universal QPSK/QAM burst receiver is a highly integrated solution that significantly decreases the board space and cost of demodulators in digital cable modem head-ends applications. The BCM3138 provides two independent cable network receivers that accept QPSK and m-QAM burst data in frequency-agile, time-division multiple access (TDMA) schemes. Advanced features in the BCM3138 include an analog front end (AFE), a QAM demodulator, a generalized equalizer and an enhanced Reed Solomon (RS) FEC decoder with dynamic deinterleaving.

The AFE provides coarse gain setting and A-to-D conversion (ADC) on either an IF input or baseband I/Q inputs. When the internal ADC is bypassed, the on-chip digital mixer translates the desired signal at RF to true DC where the I and Q samples pass through variable decimators and matched raised-cosine filters. The BCM3138 incorporates unique word detections of programmable length and pattern in the burst preamble for signal acquisition as fast as 16 symbols. An adaptive equalizer and ingress canceller characterizes the RF channel response, cancels ingress noise and removes inter-symbol interference (ISI) caused by micro-reflections in the channel. The FEC decoder consists of a programmable

de-randomizer, a programmable RS decoder with T values programmable up to 16 and a byte deinterleaver with burst-by-burst reconfiguration capability.

The BCM3138 delivers the recovered data stream and accepts receiver control inputs through a receive interface linked to a DOCSIS MAC chip such as the BCM3212. The BCM3138 prepends ranging and data information to each received code word and packet for processing by the BCM3212. The BCM3138 can be configured through either an SPI or I2C-compatible serial interface.

The BCM3138 is a highly integrated, mixed-signal and cost-effective device providing a worldwide solution for burst receiver applications. The dual receiver design of the BCM3138 is packaged in a 208-pin PQFP, enabling a significant increase upstream channel density for head-end based CMTS equipment. The BCM3138, combined with the BCM3034 QAMLink® Universal Modulator and the BCM3212 Advanced QAMLink® CMTS MAC, provides a complete solution for advanced cable headend equipment.

Broadcom®, the pulse logo, and Connecting everything® are trademarks of Broadcom Corporation and/or its subsidiaries in the United States and certain other countries. All other trademarks mentioned are the property of their respective owners.

Connecting
everything®



BROADCOM CORPORATION
16215 Alton Parkway, P.O. Box 57013
Irvine, California 92619-7013

© 2004 by BROADCOM CORPORATION. All rights reserved.

3138-PB04-R 07/01/04

Phone: 949-450-8700
Fax: 949-450-8710
E-mail: info@broadcom.com
Web: www.broadcom.com