

# HITACHI

KAOHSIUNG HITACHI  
ELECTRONICS CO.,LTD  
P.O. BOX 26-27  
2,13TH EAST ST. K.E.P.Z.  
KAOHSIUNG TAIWAN R.O.C.  
TEL:(07) 8211101(10 LINE)  
FAX:(07) 821-5860

FOR MESSRS : \_\_\_\_\_

DATE : May.28,2007

## CUSTOMER'S ACCEPTANCE SPECIFICATIONS

### SP24V001 CONTENTS

No.	ITEM	SHEET No.	PAGE
1	COVER	7B64PS 2701-SP24V001-3	1-1/1
2	RECORD OF REVISION	7B64PS 2702-SP24V001-3	2-1/1
3	MECHANICAL DATA	7B64PS 2703-SP24V001-3	3-1/1
4	ABSOLUTE MAXIMUM RATINGS	7B64PS 2704-SP24V001-3	4-1/1
5	ELECTRICAL CHARACTERISTICS	7B64PS 2705-SP24V001-3	5-1/2~2/2
6	OPTICAL CHARACTERISTICS	7B64PS 2706-SP24V001-3	6-1/2~2/2
7	BLOCK DIAGRAM	7B64PS 2707-SP24V001-3	7-1/1
8	INTERFACE TIMING CHART	7B64PS 2708-SP24V001-3	8-1/3~3/3
9	DIMENSIONAL OUTLINE	7B63PS 2709-SP24V001-3	9-1/3~3/3
10	APPEARANCE STANDARD	7B64PS 2710-SP24V001-3	10-1/5~5/5
11	PRECAUTION IN DESIGN	7B64PS 2711-SP24V001-3	11-1/3~3/3
12	DESIGNATION OF LOT MARK	7B64PS 2712-SP24V001-3	12-1/1
13	PRECAUTION FOR USE	7B64PS 2713-SP24V001-3	13-1/1

\* When product will be discontinued, customer will be informed by HITACHI with twelve months prior announcement.

ACCEPTED BY: \_\_\_\_\_

PROPOSED BY: *Dan Cheng*

KAOHSIUNG HITACHI ELECTRONICS CO.,LTD.	Sh. No.	7B64PS 2701-SP24V001-3	PAGE	1-1/1
---	------------	------------------------	------	-------

## RECORD OF REVISION

DATE	SHEET No.	SUMMARY																					
Sep.19,'02	7B64PS 2703- SP24V001-2 Page 3-1/1	Add : (9) Back Light CFL life time : 50,000h(average) Note : CFL life time = life time for half of CFL brightness.																					
	7B64PS 2703- SP24V001-2 Page 6-2/2	Changed : 6.2 VL : TYP 360 → TYP 430																					
May.28,'07	7B64PS 2709- SP24V001-3 Page 9-3/3	9.3 Internal Pin Connection Changed : CFL I / F : Mitsumi M63M83 - 04 → JAE IL-G-4S-S3C2-SA																					
	7B64PS 2712- SP24V001-3 Page 12-1/1	12. DESIGNATION OF LOT MARK Added <table border="1" style="width: 100%; border-collapse: collapse; margin-top: 5px;"> <thead> <tr> <th rowspan="2">REV No.</th> <th colspan="2">ITEM</th> <th rowspan="2">LOT No.</th> </tr> <tr> <th>CCFL Supplier</th> <th>Connector Supplier</th> </tr> </thead> <tbody> <tr> <td>A</td> <td>Wellypower</td> <td>Mitsumi M63M83 - 04</td> <td>7021T</td> </tr> <tr> <td>B</td> <td>Focuslight</td> <td>Mitsumi M63M83 - 04</td> <td>7021T</td> </tr> <tr> <td>C</td> <td>Wellypower</td> <td>JAE IL-G-4S-S3C2-SA</td> <td>7102T</td> </tr> <tr> <td>D</td> <td>Focuslight</td> <td>JAE IL-G-4S-S3C2-SA</td> <td>7102T</td> </tr> </tbody> </table>	REV No.	ITEM		LOT No.	CCFL Supplier	Connector Supplier	A	Wellypower	Mitsumi M63M83 - 04	7021T	B	Focuslight	Mitsumi M63M83 - 04	7021T	C	Wellypower	JAE IL-G-4S-S3C2-SA	7102T	D	Focuslight	JAE IL-G-4S-S3C2-SA
REV No.	ITEM			LOT No.																			
	CCFL Supplier	Connector Supplier																					
A	Wellypower	Mitsumi M63M83 - 04	7021T																				
B	Focuslight	Mitsumi M63M83 - 04	7021T																				
C	Wellypower	JAE IL-G-4S-S3C2-SA	7102T																				
D	Focuslight	JAE IL-G-4S-S3C2-SA	7102T																				

### 3. MECHANICAL DATA

- (1) Part Name SP24V001
- (2) Module Size 257.5(W)mm x 174.0(H)mm x 7.0(D)mm max.
- (3) Dot Size 0.27 (W)mm x 0.27 (H)mm
- (4) Dot Pitch 0.30 (W)mm x 0.30 (H)mm
- (5) Number of Dots 640 (W) x 480 (H)dots
- (6) Duty 1/242 (Display is divided into 2 blocks)
- (7) LCD Film type black/white (negative type)  
the upper polarizer is anti-glare type.  
The bottom polarizer is transmissive type.
- (8) Viewing Direction 12 O'clock
- (9) Back Light Cold cathode fluorescent lamp  
CFL life time : 50,000h(average)

Note : CFL life time = life time for half of CFL  
brightness.

## 4. ABSOLUTE MAXIMUM RATINGS

### 4.1 ELECTRICAL ABSOLUTE MAXIMUM RATINGS

VSS=0V : STANDARD

ITEM	SYMBOL	MIN.	MAX.	UNIT	COMMENT
Power Supply for Logic	VDD-VSS	0	6.5	V	
Power Supply for LC Drive	VDD-VEE	0	27.5	V	
Input Voltage	$V_i$	-0.3	VDD+0.3	V	Note 1
Input Current	$I_i$	0	1	A	
Static Electricity	-	-	-	-	Note 2

Note 1 DOFF,FRAME,LOAD,CP,UD0~UD3,LD0~LD3.

Note 2 Make certain you are grounded when handling LCM.

### 4.2 ENVIRONMENTAL ABSOLUTE MAXIMUM RATINGS

ITEM	OPERATING		STORAGE		COMMENT
	MIN.	MAX.	MIN.	MAX.	
Ambient Temperature	0°C Note 6	45°C Note 7	-25°C	60°C	Note 2,3
Humidity	Note 1		Note 1		Without condensation
Vibration	-	9.8m/s <sup>2</sup> (1.0G)	-	11.76m/s <sup>2</sup> (1.2G) Note 5	Note 4
Shock	-	490m/s <sup>2</sup> (50G) Note 5	-	490m/s <sup>2</sup> (50G) Note 5	3 Times for each direction of $\pm X \pm Y \pm Z$ pulse width 10mS
Corrosive Gas	Not Acceptable		Not Acceptable		

Note 1  $T_a \leq 40^\circ\text{C}$ :85%RH max.

$T_a > 40^\circ\text{C}$ :Absolute humidity must be lower than the humidity of 85%RH at  $40^\circ\text{C}$ .

Note 2  $T_a$  at  $-25^\circ\text{C}$ -----<48h , at  $60^\circ\text{C}$ -----<168h

Note 3 Background color changes slightly depending on ambient temperature. This phenomenon is reversible.

Note 4 5Hz~500Hz (Except resonance frequency) for each direction of X · Y · Z.

Any failure caused by connector loosened while testing shall be ignored.

Note 5 This module should be operated normally after finish the test.

Any failure caused by connector loosened while testing shall be ignored.

Note 6 Higher starting voltage of CFL and higher LCD driving voltage are needed while operating at  $0^\circ\text{C}$ . The life time of CFL will be reduced while operating at  $0^\circ\text{C}$ .

Need to make sure of value of IL and characteristics of inverter. Also the response time at  $0^\circ\text{C}$  will be slower.

Note 7 There are possibility that color un-uniformity happened while operating at  $45^\circ\text{C}$

## 5. ELECTRICAL CHARACTERISTICS OF LCM

### 5.1 ELECTRICAL CHARACTERISTICS

ITEM	SYMBOL	CONDITION	MIN.	TYP.	MAX.	UNIT
Power Supply Voltage for Logic	VDD-VSS	-	3.0	3.3 / 5.0	5.25	V
Input Voltage Note 1	VI	H LEVEL	0.8VDD	-	VDD	V
		L LEVEL	0	-	0.2VDD	V
Power Supply Circuit for Logic Current Note 2	IDD	VDD-VSS=3.3V	-	22.0	32.0	mA
		VDD-VSS=5.0V		20.0	30.0	
Power Supply Circuit for LC Driving Note 2	IEE	VDD-VSS=3.30V	-	20.0	27.0	mA
		VDD-VSS=5.0V		18.0	25.0	
Recommended LC Driving Voltage Note 3	VDD-VEE	Ta= 0°C , ϕ=0°	-	23.9	26.5	V
		Ta= 25°C , ϕ=0°	-	22.7	-	V
		Ta=45°C , ϕ=0°	18.5	21.6	-	V
Frame Frequency Note4	fFRAME	-	120	130	140	Hz

Note 1  $\overline{D}$ OFF,FRAME,LOAD,CP,UD0~UD3, LD0~LD3.

Note 2 fFRAME=140Hz,UD0~UD3=0,1,0,1,....LD0~LD3=1.0,1.0,....

VDD-VEE=22.7V,Ta=25°C

Note 3 Recommended LC driving voltage fluctuates about  $\pm 1.0V$  by each module.

Test pattern is all "Q".

Note 4 Need to make sure of flickering and rippling of display when setting the frame frequency in your set.

## 5.2 OPTICAL CHARACTERISTICS BACKLIGHT

(LCM, Backlight ON, Ta=25°C)

ITEM	MIN.	TYP.	MAX.	UNIT	NOTE
Brightness	-	(110)	-	cd/m <sup>2</sup>	IL=5mA Note 1,2
Rise Time	-	5	-	Minute	IL=5mA Brightness 80%
Brightness Uniformity	-	-	±30	%	Under mentioned Note 1,3

CFL : Initial, Ta=25°C, VDD-VEE=22.7V  
Display data should be all "ON"

Note 1 Measurement after 10 minutes of CFL operating.

Note 2 Brightness control : 100%

Note 3 Measurement of the following 9 places on the display.  
Definition of the brightness tolerance.

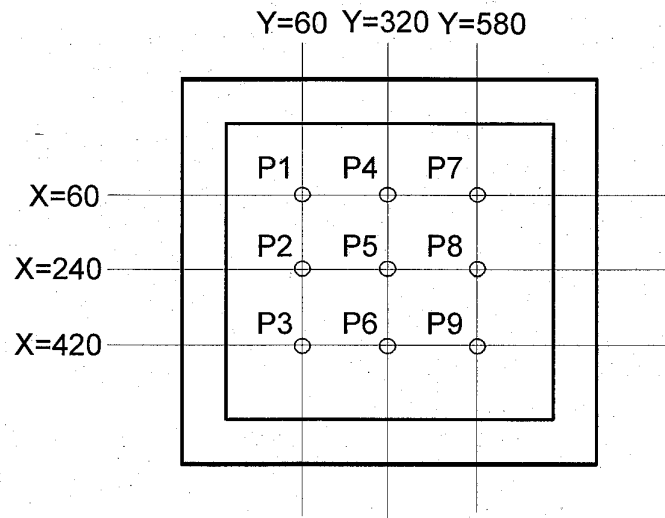

$$\left( \frac{\text{Max. Brightness or Min. Brightness} - \text{Average Brightness}}{\text{Average Brightness}} \right) \times 100$$

# 6. OPTICAL CHARACTERISTICS

## 6.1 OPTICAL CHARACTERISTICS

Ta=25°C (Backlight ON)

ITEM	SYMBOL	CONDITION	MIN.	TYP.	MAX.	UNIT	NOTE
Viewing Area	$\phi 2-\phi 1$	$K \geq 2.0$	30	40	-	deg	1,2
Contrast Ratio	K	$\phi=0^\circ \theta=0^\circ$	-	(20)	-	-	3
Response Time (Rise)	tr	$\phi=0^\circ \theta=0^\circ$	-	160	210	ms	4
Response Time (Fall)	tf	$\phi=0^\circ \theta=0^\circ$	-	110	-	ms	4

Note 1 Definition of  $\theta$  and  $\phi$   
Z (Normal)

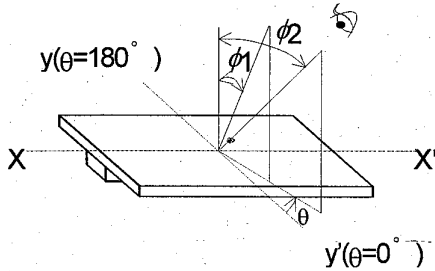

(Measure condition by HITACHI)  
Note 3 Definition of contrast "K"

$$K = \frac{\text{Brightness on Selected Dot (B1)}}{\text{Brightness on Non-Selected Dot (B2)}}$$

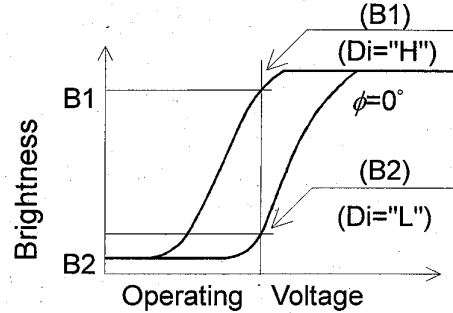

Note 2 Definition of viewing angle  $\phi 1$  and  $\phi 2$

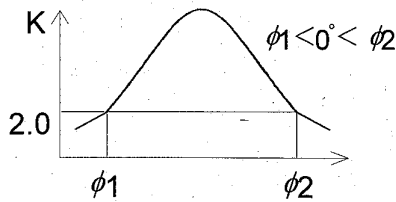

Contrast ratio K VS viewing angle  $\phi$

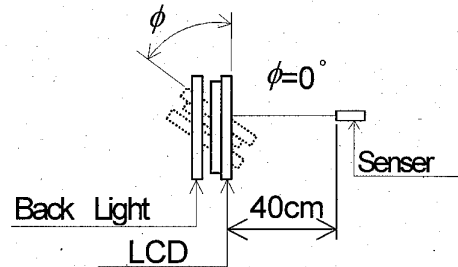

Note 4 Definition of optical response

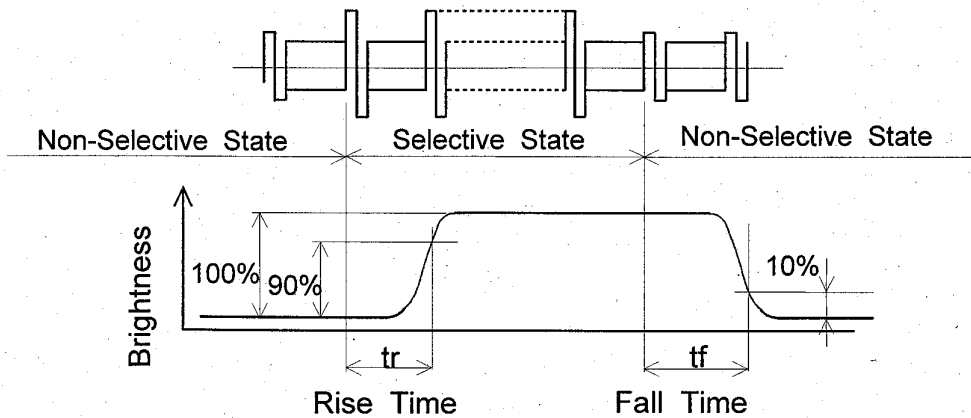

## 6.2 ELECTRICAL CHARACTERISTICS OF BACKLIGHT

ITEM	SYMBOL	MIN.	TYP.	MAX.	UNIT	NOTE
Lamp Voltage	VL	-	430	-	V	Ta=25°C
Frequency	fL	30	70	85	KHz	Ta=25°C
Lamp Current	IL	2.5	5	5.5	Ma	Ta=25°C
Starting Discharge Voltage	VS Note 2	1000	-	1500	V	Ta=25°C

Note 1 Please certainly inform HITACHI before designing lamp drive circuit according to the above specifications.

Note 2 Starting discharge voltage is increased when LCM is operating at lower temperature. please check the characteristics of inverter before applying to your set.

Note 3 Average life time of CFL will be decreased when LCM is operating at lower temperature.



# 7. BLOCK DIAGRAM

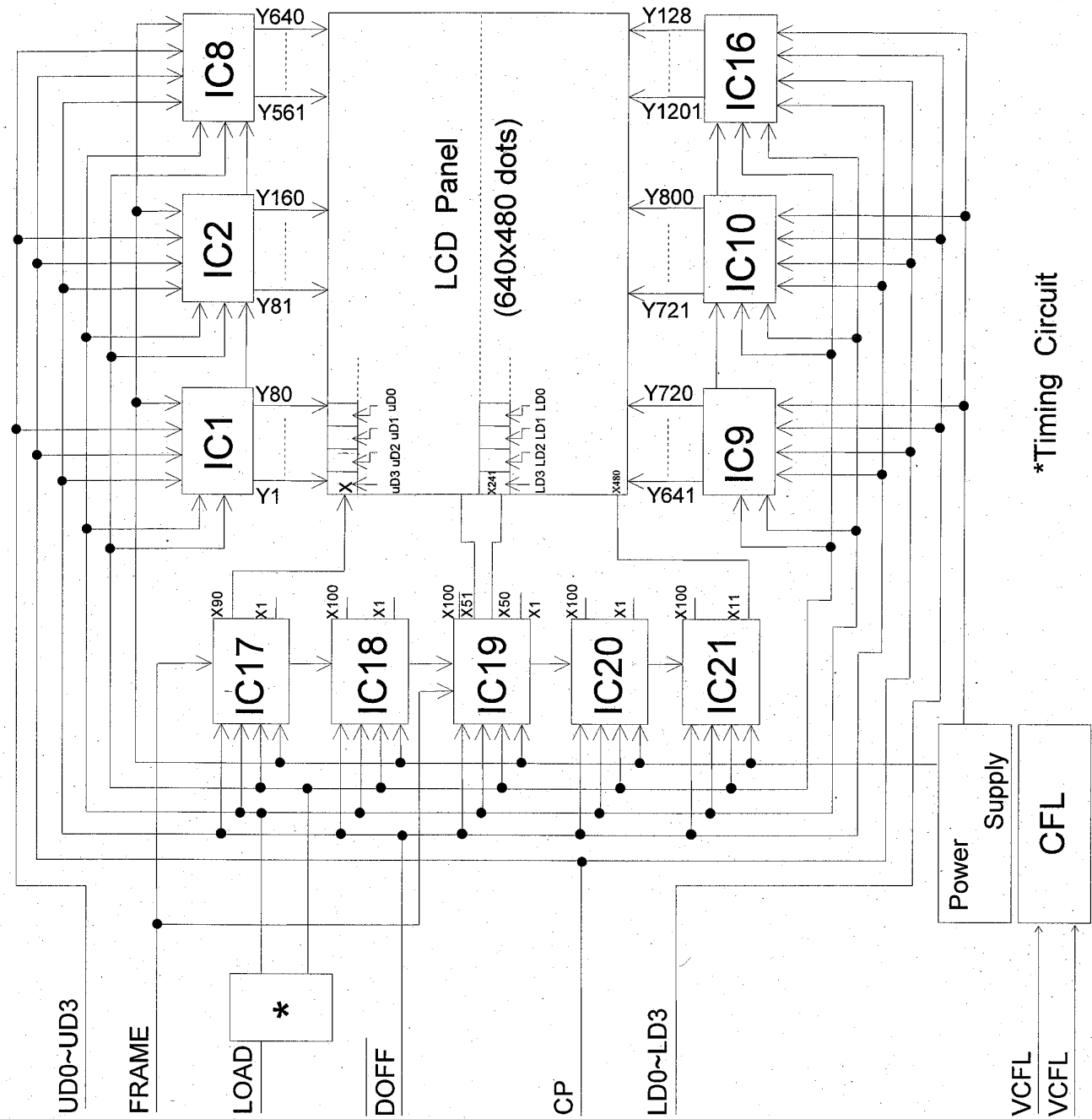

# 8. INTERFACE TIMING CHART

## 8.1 TIMING CHART

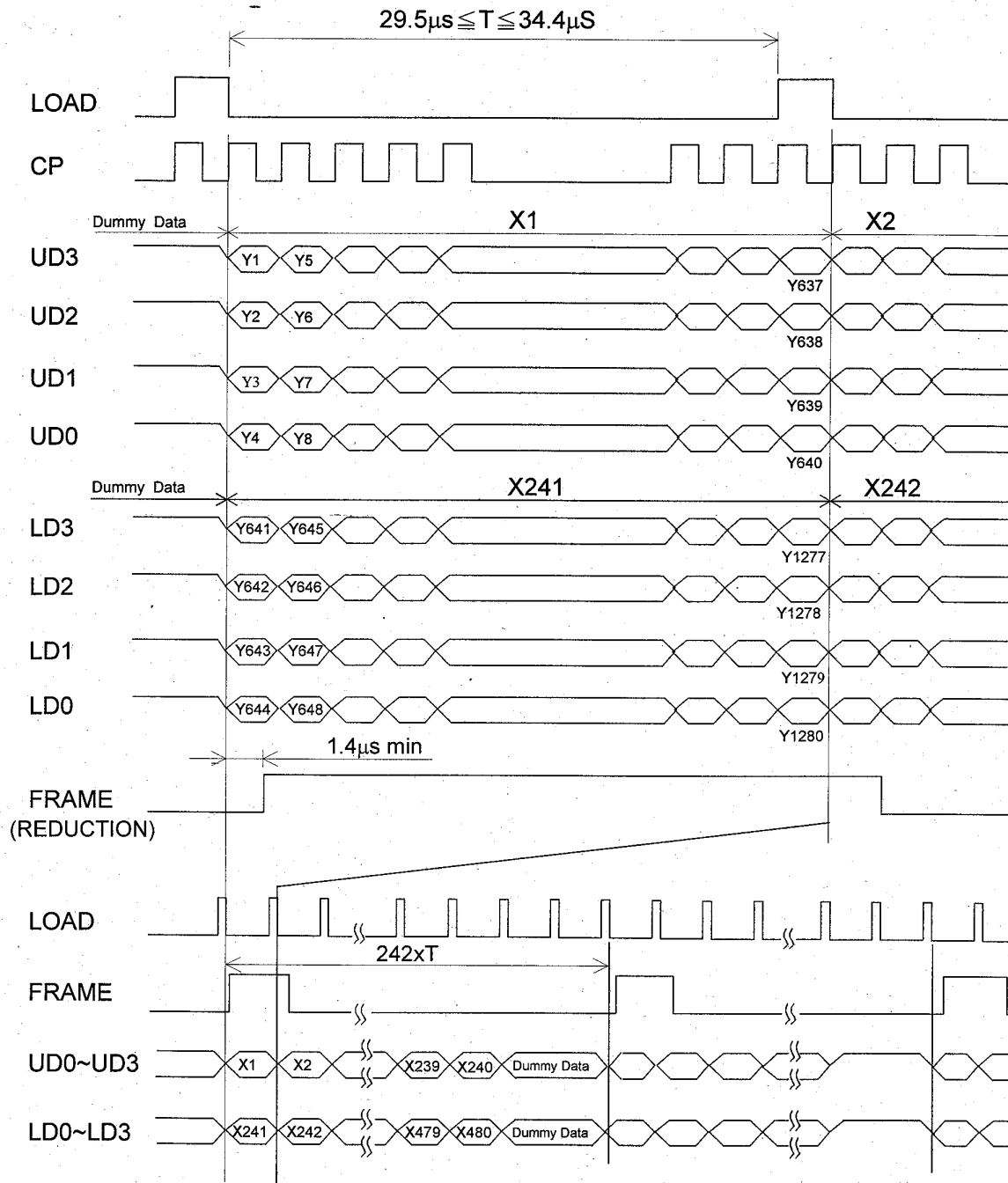

Note 1 Dummy data : "H" level.

Note 2 Do not input over 242 pulses to load.

## 8.2 TIMING CHARACTERISTICS

$0^{\circ}\text{C} \leq T_a \leq 50^{\circ}\text{C}$

$V_{DD}=3.3\text{V} \pm 0.3\text{V}, 5\text{V} \pm 0.25\text{V}$

ITEM	SYMBOL	MIN.	TYP.	MAX.	UNIT	
Clock Frequency	fCP	-	-	6.5	MHz	
Clock Pulse Width	tW	63	-	-	ns	
Clock Rise, Fall Time	tr,tf	-	-	20	ns	
Data Set Up Time	tDSU	50	-	-	ns	
Data Hold Time	tDHD	50	-	-	ns	
Load Set Up Time	tLSU	80	-	-	ns	
Load→Clock Time	tLC	VDD=3.3V	120	-	-	ns
		VDD=5V	80	-	-	
"Frame" Set Up Time	tsetup	100	-	-	ns	
"Frame" Hold Time	thold	100	-	-	ns	
"Load" Pulse Width	twc	125	-	-	ns	

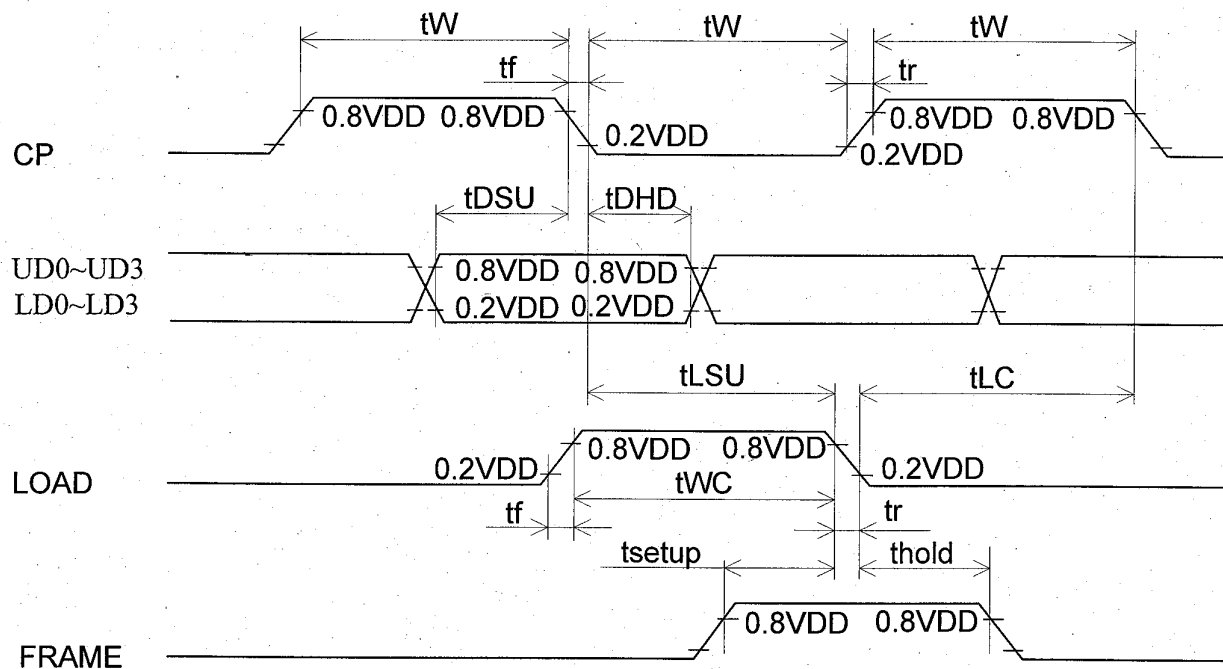

### 8.3 TIMING OF POWER SUPPLY AND INTERFACE SIGNAL

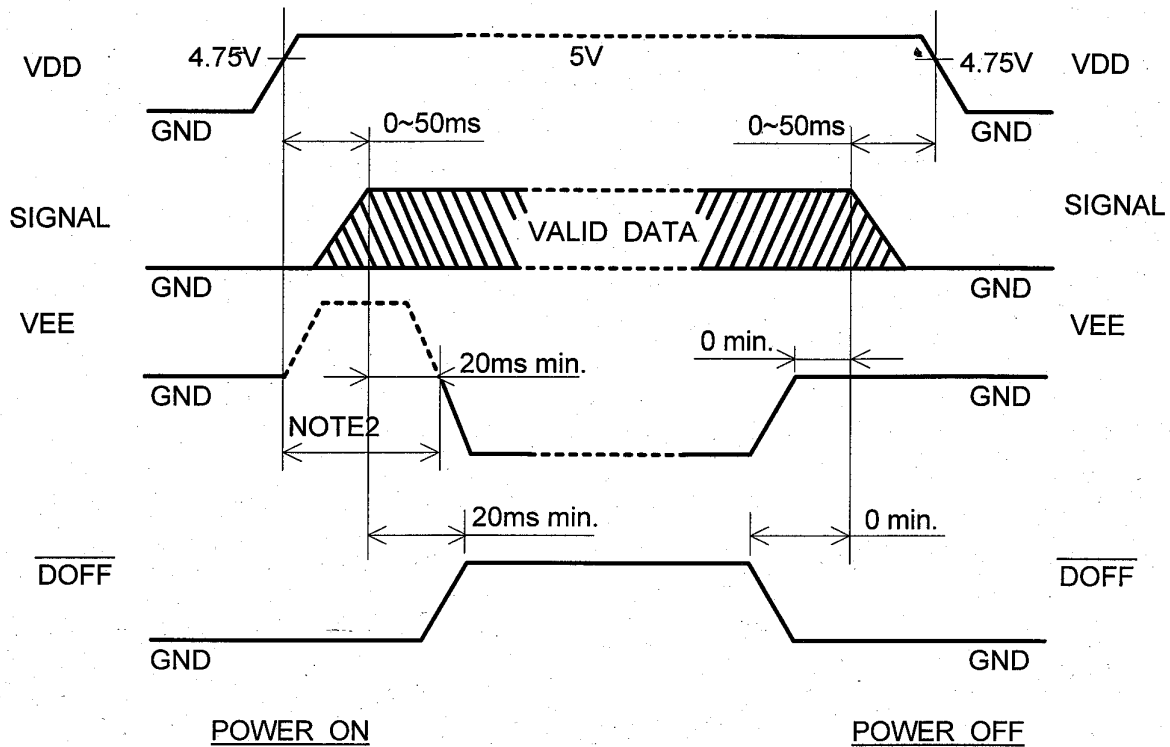

Note 1 The missing pixels may occur when the LCM is driven beyond above power interface timing sequence.

Note 2 In case of not using DOFF controlling, VEE should be at VDD level or open in this time period.

Note 3 Operation of VDD-VSS changing (3.3 $\leftrightarrow$ 5.0V) should be done after power off.

### 8.4 POWER SUPPLY FOR LCM (EXAMPLE)

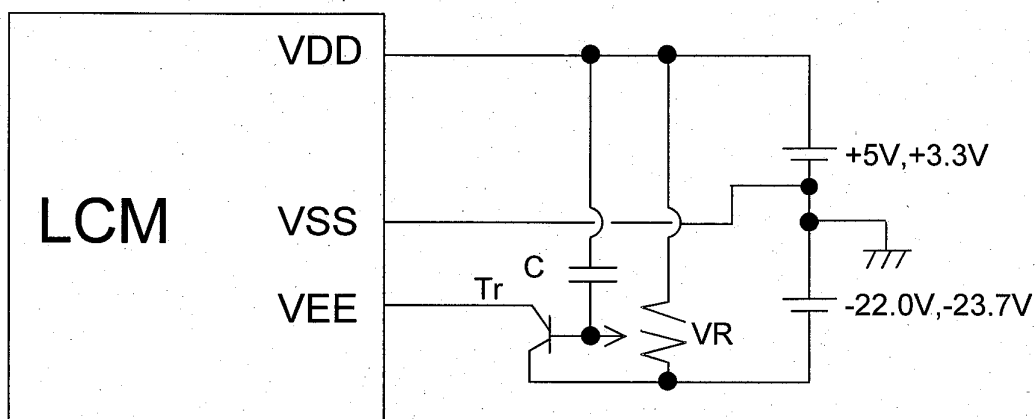

C1,C2 : 3.3 $\mu$ F(Aluminium electrolytic capacitor)

VR : 10~20k $\Omega$

Tr : 2SA673APKC (HFE=100,IC=500mA)or equivalent Tr.

9.DIMENSIONAL OUTLINE  
9.1 DIMENSIONAL OUTLINE

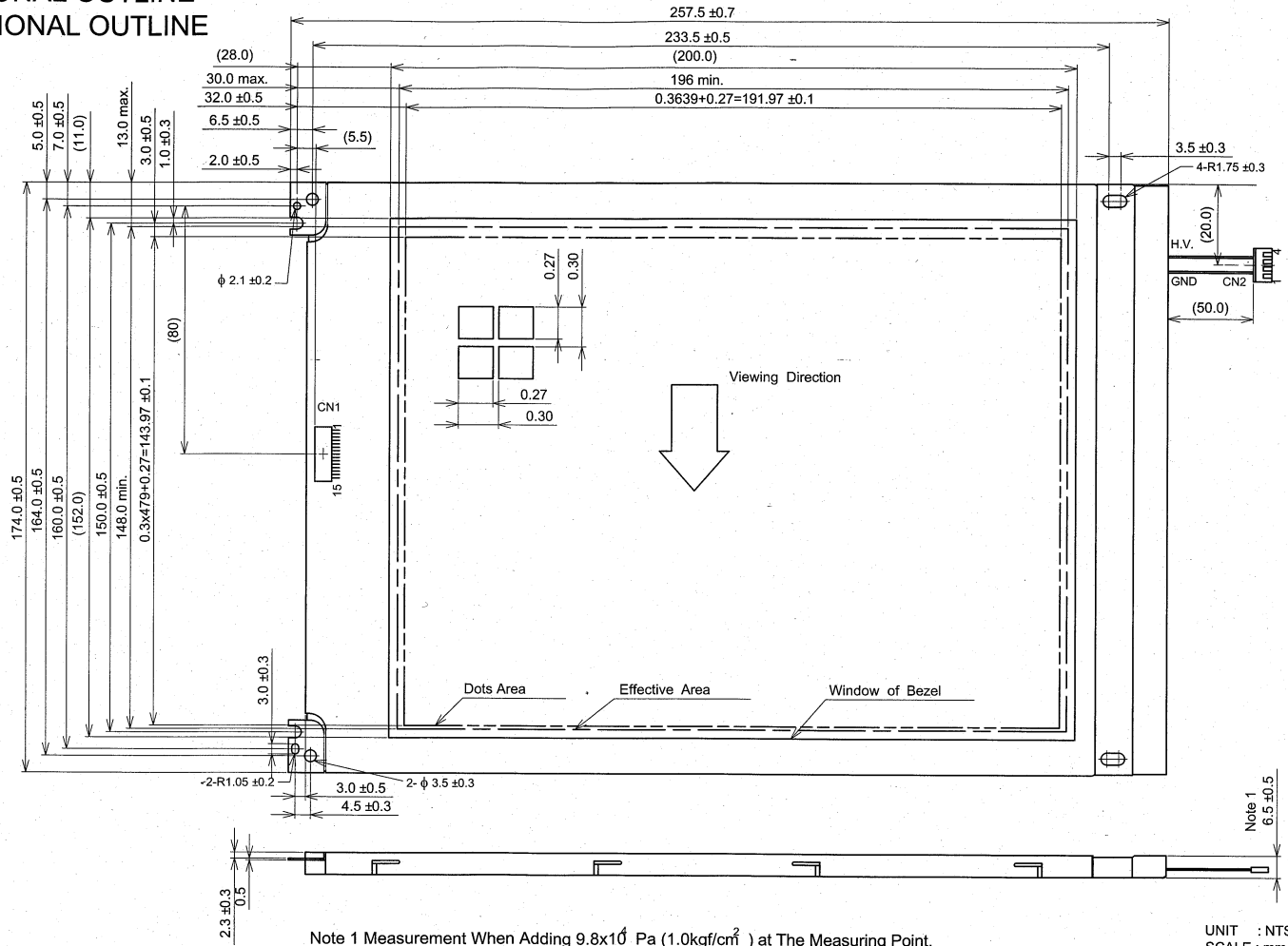

Note 1 Measurement When Adding  $9.8 \times 10^4$  Pa ( $1.0 \text{ kgf/cm}^2$ ) at The Measuring Point.

UNIT : NTS  
SCALE : mm

KAOHSIUNG HITACHI ELECTRONICS CO.,LTD.	DATE	May.28,'07	Sh. No.	7B64PS 2709-SP24V001-3	PAGE	9-1/3
---	------	------------	------------	------------------------	------	-------

## 9.2 DISPLAY PATTERN

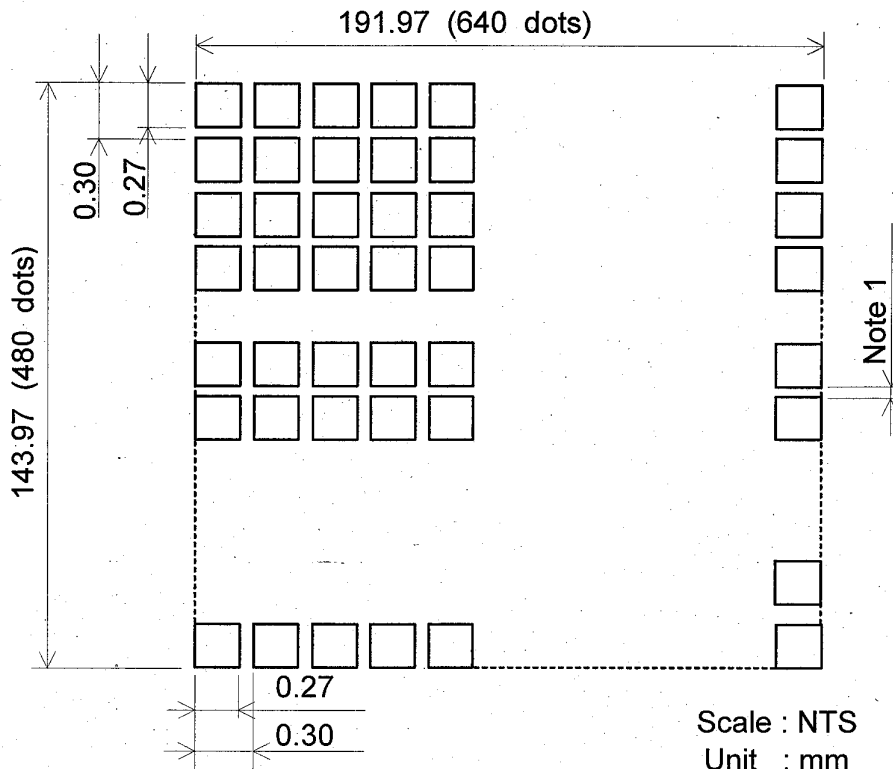

Note 1 Center-gap  $60\mu\text{m}$  max.

### 9.3 INTERNAL PIN CONNECTION

INTERFACE	PIN NO.	SIGNAL	LEVEL	FUNCTION	
LCM	I/F1	1	FRAME	H	First Line Marker
		2	LOAD	H→L	Data Latch
		3	CP	H→L	Data Shift
		4	DOFF	H/L	H : ON / L : OFF
		5	VDD	-	Power Supply for Logic
		6	VSS	-	Gnd
		7	VEE	-	Power Supply for LC
		8	UD0	H/L	Display Data (Upper Half)
		9	UD1		
		10	UD2		
		11	UD3		
		12	LD0	H/L	Display Data (Lower Half)
		13	LD1		
		14	LD2		
		15	LD3		

I/F1 : MOLEX / 53261-1510  
 (SUITABLE CONNECTOR : MOLEX / 51021-1500)

INTERFACE	PIN NO.	SIGNAL	LEVEL	FUNCTION	
CFL	CFL I/F	1	GND	-	CFL Gnd
		2	N.C	-	-
		3	N.C	-	-
		4	H.V	-	Power Supply for CFL

CFL I/F1 : JAE IL-G-4S-S3C2-SA

## 10. APPEARANCE STANDARD

### 10.1 APPEARANCE INSPECTION CONDITION

Visual inspection should be done under the following condition.

- (1) In the dark room.
- (2) With CFL panel lighted with prescribed inverter circuit.
- (3) With eyes 25cm distance from LCM.
- (4) Viewing angle within 45 degrees from the vertical line to the center of LCD.

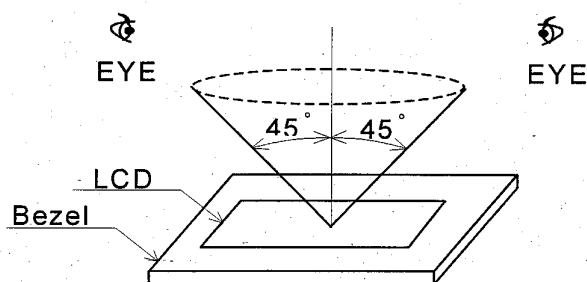

### 10.2 DEFINITION OF EACH ZONE

A zone : Within the effective area specified at page 9-1/3 of this document.

B zone : Area between the window of bezel line and the effective area line specified at page 9-1/3 of this document.

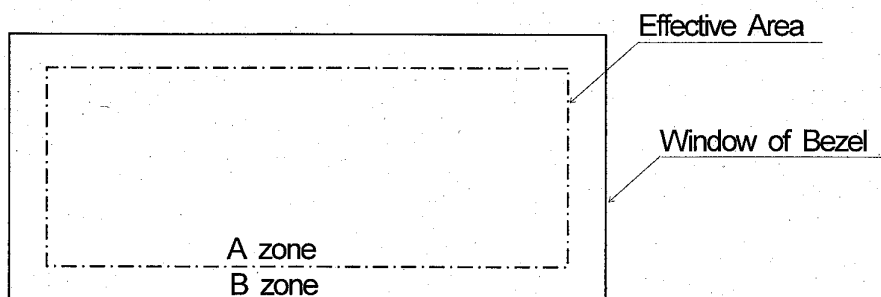



### 10.3 APPEARANCE SPECIFICATION

#### (1) LCD APPEARANCE

\*) If the problem occurs about this item, the responsible person of both party (customer and HITACHI) will discuss more detail.

No.	ITEM	CRITERIA		A	B	
L C D	Scratches	Distinguished one is not acceptable (To be judged by HITACHI standard)		*	-	
	Dent	Same as above		*	-	
	Wrinkles in Polarizer	Same as above		*	-	
	Bubbles	Average diameter D(mm)	Maximum number Acceptable		O	-
		$D \leq 0.2$	Ignored			
		$0.2 < D \leq 0.3$	12			
		$0.3 < D \leq 0.5$	3			
		$0.5 < D$	None			
	Stains, Foreign Materials Dark Spot	Filamentous			O	*
		Length L(mm)	Width W(mm)	Maximum number Acceptable		
		$L \leq 2.0$	$W \leq 0.03$	Ignored		
		$L \leq 3.0$	$0.03 < W \leq 0.05$	6		
		-	$0.05 < W$	None		
		Round			O	*
		Average diameter D(mm)	Maximum number Acceptable	Minimum Space		
		$D < 0.2$	Ignored	-		
		$0.2 \leq D < 0.3$	6	10 mm		
		$0.3 \leq D < 0.4$	4	30 mm		
	$0.4 \leq D$	None	-			
	The whole Number	Filamentous + Round = 10				
Those wiped out easily are acceptable				O	O	
Color Tone	To be judged by HITACHI standard		O	-		
Color Uniformity	Same as above		O	-		
Pinhole	$(A+B) / 2 \leq 0.15$ Maximum number : Ignored		O	-		
	$0.15 < (A+B) / 2 \leq 0.3$ Maximum number : 10					
	$C \leq 0.03$ Maximum number : Ignored					

No.	ITEM	CRITERIA				A	B
		Average diameter D(mm)	Contrast	Maximum number Acceptable	Minimum Space		
L	Contrast Irregularity (Spot)	$D \leq 0.3$	To be judged by HITACHI standard	Ignored	-	O	-
		$0.3 < D \leq 0.45$		15	20mm		
		$0.45 < D \leq 0.6$		5	20mm		
		$0.6 < D \leq 0.8$		3	50mm		
		$0.8 < D$		None	-		
C D	Contrast Irregularity (Line) (A pair of Scratch)	Width W(mm)	Length L(mm)	Maximum number Acceptable	Minimum Space	O	-
		$W \leq 0.25$	$L \leq 1.2$	2	20mm		
		$W \leq 0.2$	$L \leq 1.5$	3	20mm		
		$W \leq 0.15$	$L \leq 2.0$	3	20mm		
		$W \leq 0.1$	$L \leq 3.0$	4	20mm		
		The whole number		6			
	Rubbing Scratch	To be judged by HITACHI standard					

(2) CFL BACKLIGHT APPEARANCE

No.	ITEM	CRITERIA			A	B
C F L	Dark Spots	Average diameter		Maximum number	0	-
	White Spot	D(mm)		Acceptable		
	Foreign Materials (Spot)	$D \leq 0.4$		Ignored		
		$0.4 < D$		None		
B A C K L I G H T	Foreign Materials (Line)	Width	Length	Maximum number	0	-
		W(mm)	L(mm)	Acceptable		
		$W \leq 0.2$	$L \leq 2.5$	1		
			$2.5 < L$	None		
$0.2 < W$	-	None				
L I G H T	Scratches	Width	Length	Maximum number	0	-
		W(mm)	L(mm)	Acceptable		
		$W \leq 0.1$	-	Ignored		
		$0.1 < W \leq 0.2$	$L \leq 11.0$	1		
			$11.0 < L$	None		
$0.2 < W$	-	None				

Note

(1) Definition of average diameter D

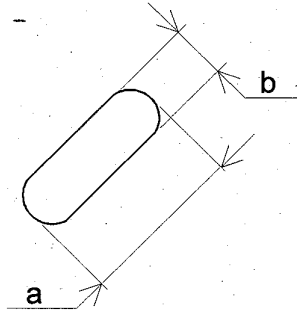

$$D = \frac{a+b}{2}$$

(2) Definition of length L and width W

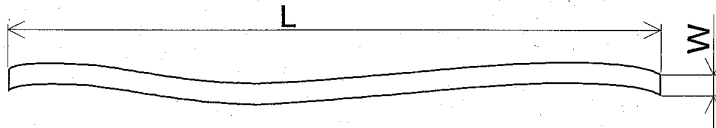

(3) Definition of pinhole

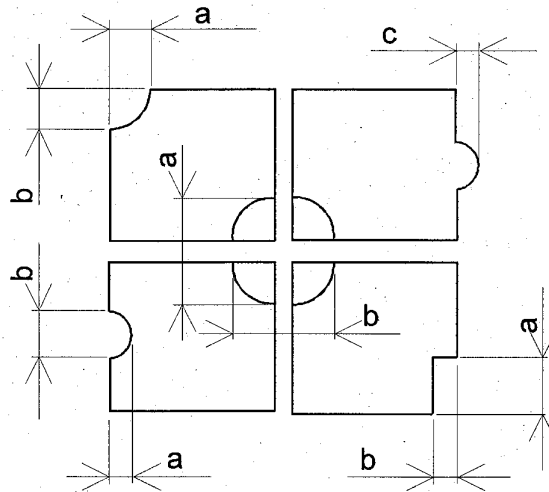

C : Salience

# 11. PRECAUTION IN DESIGN

## 11.1 MOUNTING METHOD

Since the module is so constructed as to be fixed by utilizing fitting holes in the module as shown below, it is necessary to take consideration the following items on attachment to a frame.

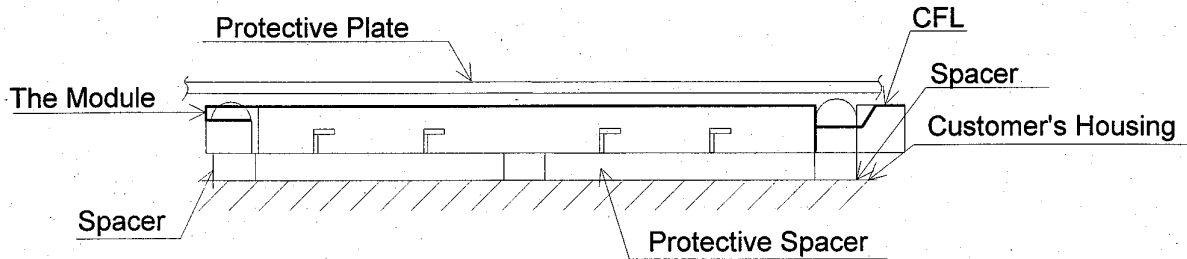

Example of Mounting

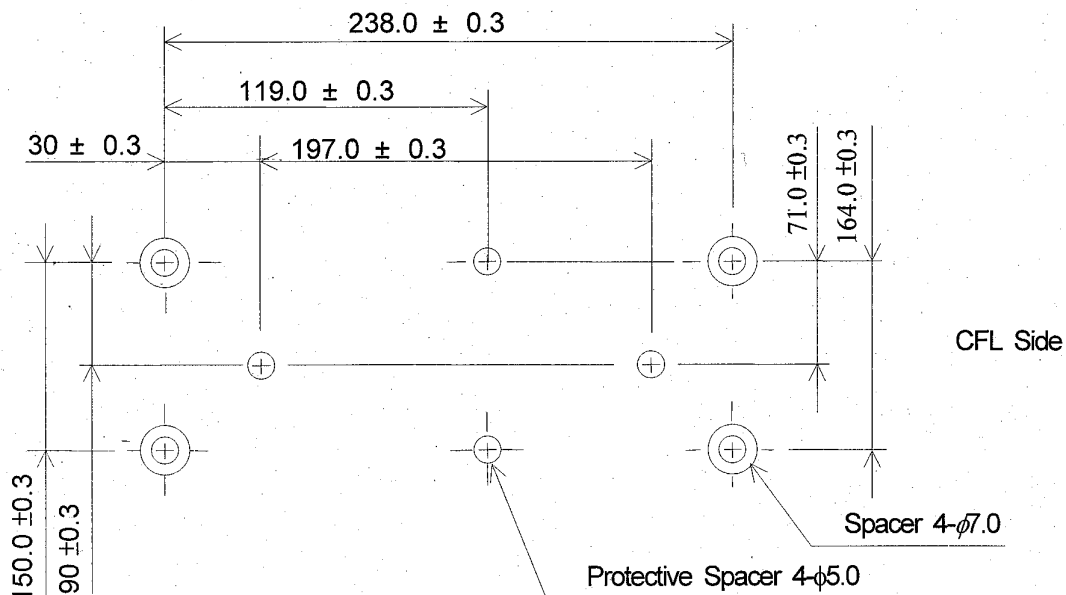

Location of Spacers

Unit:mm  
Scale:NTS

- (1) Use of protective plate, made of an acrylic plate, etc, in order to protect a polarizer and LC cell.
- (2) To prevent the module cover from being pressed, the spacers between the module and the fitting plates should be longer than 0.5mm.
- (3) We recommend you to use protective spacer as figure for protecting the module from any kind of shock to your set.

## 11.2 LC DRIVING VOLTAGE (VEE) AND VIEWING ANGLE RANGE

Setting VEE out of the recommended condition will be a cause for a change of viewing angle range.

### 11.3 CAUTION AGAINST STATIC CHARGE

As this module is provided with C-MOS LSIs the care to take such a precaution as to grounding the operator's body is required when handling it.

### 11.4 POWER ON SEQUENCE

Input signals should not be applied to LCD module before power supply voltage is applied and reaches to specified voltage ( $5 \pm 0.25V$ ).

If above sequence is not kept, C-MOS LSIs of LCD modules may be damaged due to latch up problem.

### 11.5 PACKAGING

- (1) No. Leaving products is preferable in the place of high humidity for a long period of time. For their storage in the place where temperature is  $35^{\circ}C$  or higher, special care to prevent them from high humidity is required. A combination of high temperature and high humidity may cause them polarization degradation as well as bubble generation and polarizer peel-off. Please keep the temperature and humidity within the specified range for use and storing.
- (2) Since upper polarizers and lower aluminum plates tend to be easily damaged, they should be handled with full care so as not to get them touched, pushed or rubbed by a piece of glass, tweezers and anything else which are harder than a pencil lead 3H.
- (3) As the adhesives used for adhering upper/lower polarizers and aluminum plates are made of organic substances which will be deteriorated by a chemical reaction with such chemicals as acetone, toluene ethanol and isopropyl-alcohol. The following solvents are recommended for use:  
Normal Hexane  
Please contact us when it is necessary for you to use chemicals other than the above.
- (4) Lightly wipe to clean the dirty surface with absorbent cotton waste or other soft material like chamois, soaked in the chemicals recommended without scrubbing it hardly. To prevent the display surface from damage and keep the appearance in good state, it is sufficient, in general, to wipe it with absorbent cotton.
- (5) Immediately wipe off saliva or water drop attached on the display area because its long period adherence may cause deformation or faded color on the spot.
- (6) Foggy dew deposited on the surface and contact terminals due to coldness will be a cause for polarizer damage, stain and dirt on product. When necessary to take out the products from some place at low temperature for test, etc. It is required for them to be warmed up in a container once at the temperature higher than that of room.

- (7) Touching the display area and contact terminals with bare hands and contaminating them are prohibited, because the stain on the display area and poor insulation between terminals are often caused by being touched by bare hands. (There are some cosmetics detrimental to polarizers.)
- (8) In general the quality of glass is fragile so that it tends to be cracked or chipped in handling, specially on its periphery please be careful not give it sharp shock caused by dropping down, etc.

#### 11.6 CAUTION FOR OPERATION

- (1) It is an indispensable condition to drive LCD's within the specified voltage limit since the higher voltage than the limit causes the shorter LCD life. An electrochemical reaction due to direct current causes LCD's undesirable deterioration, so that the use of direct current driver should be avoided.
- (2) Response time will be extremely delayed at lower temperature than the operating temperature range and on the other hand at higher temperature LCD's show dark blue color in them. However those phenomena do not mean impediment or out of order with LCD's which will come back in the specified operating temperature range.
- (3) If the display area is pushed hard during operation, some font will be abnormally displayed but it resumes normal condition after turning off once.
- (4) A slight dew depositing on terminals is a cause for electrochemical reaction resulting in terminal open circuit. Usage under the relative condition of 40°C 50%RH less is required.

#### 11.7 STORAGE

In case of storing for a long period of time (for instance, for years) for the purpose of replacement use, the following ways are recommended.

- (1) Storage in a polyethylene bag with the opening sealed so as not to enter fresh air outside in it, and with no desiccant.
- (2) The placing in a dark room where neither exposure to direct sunlight nor light is, keeping temperature in the range from 0°C to 35°C.
- (3) Storing with no touch on polarizer surface by anything else.  
(It is recommended to store them as they have been contained in the inner container at the time of delivery from us.)

#### 11.8 SAFETY

- (1) It is recommendable to crash damaged or unnecessary LCD's into pieces and wash off liquid crystal by either of solvents such as acetone and ethanol, which should be burned up later.
- (2) When any liquid leaked out of a damaged glass gill comes in contact with your hands, please wash it off well with soap and water.

## 12. DESIGNATION OF LOT MARK

### 12.1 LOT MARK

Lot mark is consisted of 4 digits for production.

Lot and 8 digits for production control.

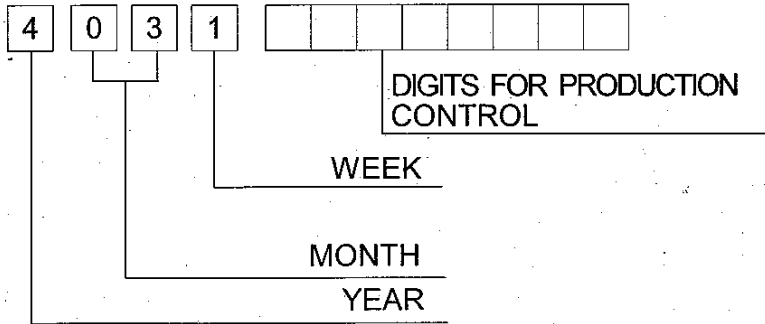

YEAR	FIGURE IN LOT MARK
2007	7
2008	8
2009	9
2010	0
2011	1

MONTH	FIGURE IN LOT MARK	MONTH	FIGURE IN LOT MARK
Jan.	01	Jul.	07
Feb.	02	Aug.	08
Mar.	03	Sep.	09
Apr.	04	Oct.	10
May	05	Nov.	11
Jun.	06	Dec.	12

WEEK (DAY IN CALENDAR)	FIGURE IN LOT MARK
1~7	1
8~14	2
15~21	3
22~28	4
29~31	5

### 12.2 REVISION

REV No.	ITEM		LOT No.
	CCFL Supplier	Connector Supplier	
A	Wellypower	Mitsumi M63M83 - 04	7021T
B	Focuslight	Mitsumi M63M83 - 04	7021T
C	Wellypower	JAE IL-G-4S-S3C2-SA	7102T
D	Focuslight	JAE IL-G-4S-S3C2-SA	7102T

### 12.3 LOCATION OF LOT MARK

on the back side of LCM

4 0 3 1 \* \* \* \* \*



### 13. PRECAUTION FOR USE

- (1) A limit sample should be provided by the both parties on an occasion when the both parties agreed its necessity. Judgment by a limit sample shall take effect after the limit sample has been established and confirmed by the both parties.
- (2) On the following occasions, the handling of the problem should be decided through discussion and agreement between responsible persons of the both parties.
  1. When a question is arisen in the specifications.
  2. When a new problem is arisen which is not specified in this specifications.
  3. When an inspection specifications change or operating condition change in customer is reported to HITACHI, and some problem is arisen in this specification due to the change.
  4. When a new problem is arisen at the customer's operating set for sample evaluation in the customer site.
- (3) Regarding the treatment for maintenance and repairing, both parties will discuss it in six months later after latest delivery of this product.

The precaution that should be observed when handling LCM have been explained above. If any points are unclear of if you have any requests, please contact HITACHI.